

ARMY TM 9-2320-387-10
AIR FORCE TO 36A12-1A-3061-1

OPERATOR'S MANUAL

FOR

**TRUCK, UTILITY: S250 SHELTER
CARRIER, 4X4, M1113
(2320-01-412-0143) (EIC: B6B)**

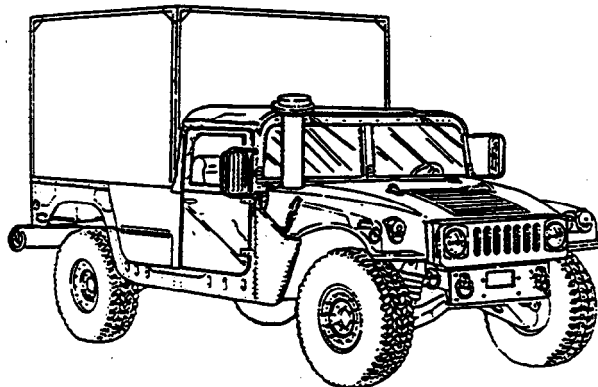

**TRUCK, UTILITY: UP-ARMORED
CARRIER, 4X4, M1114
(2320-01-413-3739) (EIC: B6C)**

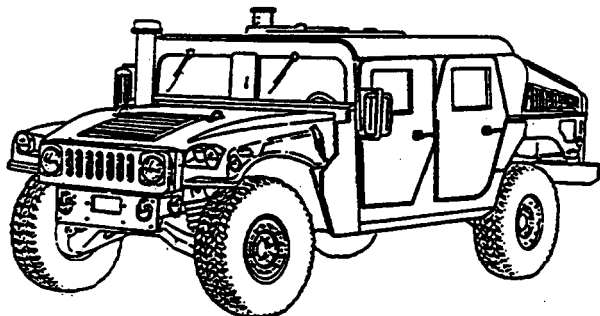

HOW TO USE THIS MANUAL iii

INTRODUCTION 1-1

OPERATING INSTRUCTIONS 2-1

MAINTENANCE INSTRUCTIONS 3-1

REFERENCES A-1

**COMPONENTS OF END
ITEM (COEI) AND BASIC ISSUE
ITEMS (BII) LISTS** B-1

**ADDITIONAL AUTHORIZATION
LIST (AAL)** C-1

**EXPENDABLE/DURABLE
SUPPLIES AND MATERIALS LIST** D-1

STOWAGE AND SIGN GUIDE E-1

**ON-VEHICLE EQUIPMENT
LOADING PLANS** F-1

LUBRICATION INSTRUCTIONS G-1

INDEX INDEX 1

Approved for public release; distribution is unlimited.

**HEADQUARTERS, DEPARTMENTS OF THE ARMY AND
THE AIR FORCE**

OCTOBER 1997

WARNING**EXHAUST GASES CAN KILL**

Brain damage or death can result from heavy exposure. Precautions must be followed to ensure crew safety when the personnel heater or engine of any vehicle is operated for any purpose.

1. Do not operate your vehicle engine in enclosed areas.
2. Do not idle vehicle engine with windows closed.
3. Be alert at all times for exhaust odors.
4. Be alert for exhaust poisoning symptoms. They are:
 - Headache
 - Dizziness
 - Sleepiness
 - Loss of muscular control
5. If you see another person with exhaust poisoning symptoms:
 - Remove person from area
 - Expose to open air
 - Keep person warm
 - Do not permit physical exercise
 - Administer artificial respiration, if necessary*
 - Notify a medic

*For artificial respiration, refer to FM 21-11.

6. BE AWARE, the field protective mask for Nuclear, Biological, or Chemical (NBC) protection will not protect you from carbon monoxide poisoning.

THE BEST DEFENSE AGAINST EXHAUST POISONING IS ADEQUATE VENTILATION.

WARNING SUMMARY

- Do not attempt to operate cargo shell door forward latch. The cargo shell door is not to be opened from inside the vehicle. Opening cargo shell door from inside the vehicle may cause damage to equipment or injury to personnel.
- Drycleaning solvent is flammable and will not be used near an open flame. A fire extinguisher will be kept nearby when the solvent is used. Use only in well-ventilated places. Failure to do this may result in injury to personnel and/or damage to equipment.
- Protective gloves, clothing, and/or respiratory equipment must be worn whenever caustic, toxic, or flammable cleaning solutions are used. Failure to do this may result in injury to personnel.
- Do not perform fuel or battery system checks, inspections, or maintenance while smoking or near sparks. Fuel may ignite and batteries may explode, causing damage to vehicle and injury or death to personnel.
- Never use transmission shift lever in place of parking brake. Set parking brake. Ensure transmission shift lever is in P (park) position and transfer case shift lever is NOT in N (neutral) position. Damage to equipment and injury to personnel may occur if these instructions are not followed.
- Ensure all slack from three-point seatbelt adjusting strap or three-point seatbelt is removed. Three-point seatbelt retracts and will lock only during sudden stops or impact. Injury to personnel may result if an accident occurs and seatbelts are not in use or adjusted properly.
- This vehicle has been designed to operate safely and efficiently within the limits specified in this TM. Operations beyond these limits are prohibited IAW AR 70-1 without written approval from the Commander, U.S. Army Tank-automotive and Armaments Command, ATTN: AMSTA-CM-S, Warren, MI 48397-5000.
- Use extreme caution when transporting personnel. Rollover protection is available for the crew area only and is not provided in the troop/cargo area. Although certain design characteristics of the vehicle, such as vehicle width, ground clearance, independent suspension, etc., provide improved capabilities, accidents can still happen.
- Operators are reminded to observe basic safe driving techniques/skills when operating the vehicle, especially when transporting personnel. Vehicle speed must be reduced consistent with weather and road/terrain conditions. Obstacles such as stumps and boulders must be avoided. Failure to use basic safe driving techniques/skills may result in injury or death to personnel and damage to equipment.
- Prior to towing vehicle with rear wheels up, secure steering wheel to prevent front wheels from turning.
- Wear leather gloves when handling winch cable. Do not handle cable with bare hands. When fully extending winch cable, ensure that four wraps of winch cable remain on drum at all times. Direct all personnel to stand clear of winch cable during winch operation. Failure to do this may cause damage to vehicle and injury or death to personnel.

WARNING SUMMARY (Cont'd)

- Avoid using fire extinguisher in unventilated areas. Prolonged inhalation exposure to extinguishing agent or fumes from burning material may cause injury to personnel. Using fire extinguisher in windy area will cause rapid dispersal of extinguishing agent and reduce effectiveness in fire control.
- Vehicle operation in snow is a hazardous condition. Operator must travel at reduced speeds and be prepared to meet sudden changes in road conditions. Pump brakes gradually when stopping vehicle on ice or snow. Sudden braking will cause wheels to lock and vehicle to slide out of control, causing damage to vehicle and injury or death to personnel.
- Do not rely on wet service brakes. Keep applying brakes until they dry out and uneven braking ceases. Failure to do this may cause damage to vehicle and injury or death to personnel.
- Exhaust components are hot after prolonged vehicle use. Ensure exhaust system components are cool before removing/installing exhaust assembly. Failure to do this may result in injury to personnel.
- Do not use hand throttle as an automatic speed or cruise control. The hand throttle does not automatically disengage when brake is applied, resulting in increased stopping distances and possible hazardous and unsafe operation. Injury to personnel or damage to equipment may result.
- To ensure opening of hood is accomplished safely and effectively, always maintain the proper lifting posture, with legs bent and back straight. When raising and securing hood, ensure hood prop rod is secured to hood support bracket. When releasing hood prop rod, do not pull rod at hook end. Damage to equipment or injury to personnel may occur if hood is not raised, secured, and lowered properly.
- If NBC exposure is suspected, all air filter media should be handled by personnel wearing protective equipment. Consult your unit NBC officer or NBC NCO for appropriate handling or disposal instructions.
- Due to tire load ratings and vehicle load carrying capabilities, only the load range D radial tire can be used.
- Hearing protection is required for driver and passengers when engine is running. Noise levels produced by these vehicles exceed 85 dBA, which may cause injury to personnel.
- Do not operate the vehicle without windshield assembly positioned upright and the B-pillar securely attached. Operation of vehicle without these structures in place may result in injury to personnel and damage to equipment.
- Chock blocks shall be used when parking a vehicle with inoperative parking brakes, operating in extreme cold conditions, parking on inclines, or whenever and wherever maintenance is being performed. Failure to do so may result in injury to personnel or damage to equipment.
- Do not operate the vehicular heater in a closed area without proper exhaust evacuations. Damage to heater or injury to personnel may result.
- Do not operate the vehicular heater when refueling. Damage to heater or injury to personnel may result.
- Use care when opening and closing doors. Do not rest fingers in door opening. Personnel injury may result.

ARMY TM 9-2320-387-10
AIR FORCE TO 36A12-1A-3061-1

TECHNICAL MANUAL
NO. 9-2320-387-10

HEADQUARTERS,
DEPARTMENTS OF THE ARMY
AND THE AIR FORCE

TECHNICAL ORDER
NO. 36A12-1A-3061-1

WASHINGTON, D.C., 17 October 1997

OPERATOR'S MANUAL FOR

TRUCK, UTILITY: S250 SHELTER CARRIER,
4X4, M1113
(2320-01-412-0143) (EIC: B6B)

TRUCK, UTILITY: UP-ARMORED CARRIER,
4X4, M1114
(2320-01-413-3739) (EIC: B6C)

Approved for public release; distribution is unlimited.

REPORTING OF ERRORS

You can help improve this manual. If you find any mistakes or if you know of a way to improve the procedures, please let us know. Mail your letter, DA Form 2028 (Recommended Changes to Publications and Blank Forms), or DA Form 2028-2, located in the back of this manual, directly to: Director, Armament and Chemical Acquisition and Logistics Activity, ATTN: AMSTA-AC-NMLI, Rock Island, IL 61299-7630. A reply will be furnished to you. You may also provide DA Form 2028-2 information via datafax or e-mail:

- Email: amsta-ac-nml@ria-emh2.army.mil
- Fax: DSN 793-0726 or commercial (309) 782-0726

TABLE OF CONTENTS

	Page
HOW TO USE THIS MANUAL	iii
CHAPTER 1. INTRODUCTION	1-1
Section I. General Information	1-1
II. Equipment Description	1-3
III. Principles of Operation.	1-13
CHAPTER 2. OPERATING INSTRUCTIONS	
Section I. Description and Use of Operator's Controls and Indicators	2-1
II. Preventive Maintenance Checks and Services (PMCS) . .	2-24
III. Operation Under Usual Conditions	2-61
IV. Operation Under Unusual Conditions	2-103
V. S250 Shelter Carrier Operation	2-124
VI. M1114 Up-Armored Carrier Stowage Net Operation. . . .	2-132
CHAPTER 3. MAINTENANCE INSTRUCTIONS.	3-1
Section I. Lubrication	3-1
II. Troubleshooting.	3-2
III. Maintenance Procedures	3-8
APPENDIX A. REFERENCES	A-1
APPENDIX B. COMPONENTS OF END ITEM (COEI) AND BASIC ISSUE ITEMS (BII) LISTS	B-1
Section I. Introduction	B-1
II. Components of End Item	B-2
III. Basic Issue Items.	B-3
APPENDIX C. ADDITIONAL AUTHORIZATION LIST (AAL)	C-1
Section I. Introduction	C-1
II. Additional Authorization List	C-2
APPENDIX D. EXPENDABLE/DURABLE SUPPLIES AND MATERIALS LIST.	D-1
Section I. Introduction	D-1
II. Expendable/Durable Supplies and Materials List.	D-2
APPENDIX E. STOWAGE AND SIGN GUIDE.	E-1
APPENDIX F. ON-VEHICLE EQUIPMENT LOADING PLANS	F-1
APPENDIX G. LUBRICATION INSTRUCTIONS.	G-1
INDEX	Index 1

HOW TO USE THIS MANUAL

ABOUT YOUR MANUAL

Spend some time looking through this manual. You'll find that it takes a positive approach and clearly states only what you can do. Before attempting any questionable operation which is not specifically authorized in this manual, clearance must be obtained from your supervisor.

Features added to improve the convenience of this manual and increase your efficiency are:

- a. **Accessing Information** – Troubleshooting guides for specific systems lead directly to step-by-step directions for problem solving. Maintenance tasks use preventive maintenance checks and services for each vehicle.
- b. **Illustrations** – A variety of methods are used to make locating and identifying components easier. Locator illustrations with keyed text, exploded views, and cut-away diagrams make the information in this manual easier to understand and follow.
- c. **Keying Text With Illustrations** – Instructions/text are located together with figures that illustrate the specific task you are working on. Generally, the task steps and figures are located side by side.

USING YOUR MANUAL: EXAMPLE 1

TASK: You are starting your M1113 or M1114 vehicle engine and are in need of instructions to complete this procedure.

OPERATING INSTRUCTION STEPS:

1. Look for **OPERATING INSTRUCTIONS** in the table of contents (page ii) of this manual.
2. Look through the list of section titles until you find section III, Operation Under Usual Conditions.
3. Turn to page 2-61 as indicated.

TM 9-2320-387-10	
TABLE OF CONTENTS	
	Page
HOW TO USE THIS MANUAL	ii
CHAPTER I INTRODUCTION	1-1
Section I. General Information	1-1
II. Equipment Description	1-3
III. Principles of Operation	1-13
CHAPTER 2 OPERATING INSTRUCTIONS	
Section I. Descriptions and Use of Operator's Controls and Indicators	2-1
II. Preventive Maintenance Checks and Services (PMCS)	2-24
III. Operations Under Usual Conditions	2-61
IV. Operations Under Unusual Conditions	2-103
V. S250 Shaltar Carrier Operations	2-124
CHAPTER 3 MAINTENANCE INSTRUCTIONS	3-1
Section I. Lubrication	3-1
II. Troubleshooting	3-2
III. Maintenance Procedures	3-8
APPENDIX A REFERENCES	A-1
APPENDIX B COMPONENTS OF END ITEM (COEI) AND BASIC ISSUE ITEMS (BI) LISTS	B-1
Section I. Introduction	B-1
II. Components of End Item	B-2
III. Basic Issue Items	B-3
APPENDIX C ADDITIONAL AUTHORIZATION LIST (AAL)	C-1
Section I. Introduction	C-1
II. Additional Authorization List	C-2
APPENDIX D EXPENDABLE/DURABLE SUPPLIES AND MATERIALS LIST	D-1
Section I. Introduction	D-1
II. Expendable/Durable Supplies and Materials List	D-2
APPENDIX E STOWAGE AND SIGN GUIDE	E-1
APPENDIX F ON-VEHICLE EQUIPMENT LOADING PLANS	F-1
APPENDIX G LUBRICATION INSTRUCTIONS	G-1
INDEX	Index I

HOW TO USE THIS MANUAL (Cont'd)

4. On page 2-61 look through the Operation Under Usual Conditions reference index for starting the engine.
5. Starting on page 2-62 and continuing through page 2-64, you will find directions for starting the engine listed in progressive order.
6. Before performing the operating instruction steps, take time to examine and familiarize yourself with the complete operation procedure and required PMCS.
7. Procedures include everything you must do to accomplish a basic operations task.
8. Numbered callouts, found with the art and text and arranged in a clockwise pattern, will make it easier for you to identify and locate instruments and controls.
9. Pay particular attention to all notes, cautions, and warnings. They are designed to assist you with your task, prevent damage to the vehicle and its components, and protect you from injury.

TM 9-2320-387-10

Section III. OPERATION UNDER USUAL CONDITIONS

2-9. GENERAL

This section provides instructions for vehicle operations under moderate temperatures, humidity and terrain conditions. For vehicle operations under unusual conditions, refer to section IV of this chapter.

2-10. OPERATION UNDER USUAL CONDITIONS REFERENCE INDEX

REF. PARA.	TITLE	PAGE NO.
2-11.	Break-in Service	2-62
2-12.	Starting the Engine	2-62
2-13.	Placing Vehicle in Motion	2-66
2-14.	Stopping the Vehicle and Engine	2-68
2-15.	Operation of Vehicle Light Switch	2-70
2-16.	Adjusting Driver's Seat	2-72
2-17.	Constant Speed Assembly and Battery Box Cover Replacement	2-73
2-18.	Seatbelt Operation	2-74
2-19.	Defroster Operation (M1113)	2-75
2-20.	Defogger Operation (M1114)	2-76
2-21.	Heater Operation	2-77
2-22.	Throttle Operation	2-78
2-23.	Slave Starting Operation	2-79
2-24.	Passenger 2nd Row Storage (M1115) Operation	2-80
2-25.	Passenger 2nd Row Storage (M1114) Operation	2-82
2-26.	Turning Operations	2-84
2-27.	Trailer Towing	2-89
2-28.	Electric Wash Operations	2-90
2-29.	Fog Eliminator Operation	2-94
2-30.	Crew Door Operation (M1114)	2-95
2-31.	C- Pillar Door Operation (M1114)	2-96
2-32.	Cargo Shelf Door Operation (M1114)	2-97
2-33.	Upward-Opening Storage Operations (M1114)	2-98
2-34.	Fuel Door Operation (M1114)	2-100
2-35.	Air Conditioner Operation (M1114)	2-101
2-36.	Washdown Device Operation (M1114)	2-102

2-61

TM 9-2320-387-10

2-11. BREAK-IN SERVICE

NOTE

Before you operate your vehicle, be sure to perform the preventive maintenance checks and services shown in table 2-2.

- a. Perform all break-in service before operation checks and service as indicated in table 2-2.
- b. Upon receipt of vehicle, or after engine replacement, the following break-in speeds and procedures should be observed during the first 500 mi (805 km) of operation:
 - Do not exceed a speed of 55 mph (89 kph).
 - Do not drive for long periods of time at constant speed.
 - Avoid rapid acceleration or deceleration.
 - Drive at a moderate speed until the engine is fully warmed up.
 - Do not tow trailer.

2-12. STARTING THE ENGINE

WARNING

- The automatic transmission has a PARK position. Never use the shift lever in place of the parking brake. Set the parking brake. Make sure the transmission shift lever is in the P (park) position and transfer case shift lever is NOT in the N (neutral) position. Damage to equipment and injury to personnel may occur if these instructions are not followed.
- Check fluids w/2 be used when parking a vehicle with inoperative parking brakes, operating in extreme cold conditions, parking on inclines, or whenever and wherever maintenance is being performed. Failure to do so may result in injury to personnel or damage to equipment.
- Hearing protection is required for driver and passengers when engine is running. Noise levels produced by these vehicles exceed 82 dBA, which may cause injury to personnel.

- a. Ensure parking brake is applied.
- b. Adjust driver's seat (para. 2-34).
- c. Adjust left and right rearview mirrors. Ensure both mirrors provide a clear view (para. 2-34).
- d. Ensure all windows are clean. If not, clean windows before attempting to move vehicle (table 2-1).

2-62

USING YOUR MANUAL: EXAMPLE 2

TASK: Your M1113 or M1114 engine cranks but does not start.

TROUBLESHOOTING STEPS:

1. Look for **MAINTENANCE INSTRUCTIONS** in the of table of contents (page ii) of this manual.
2. Look through the list of section titles until you find section II, Troubleshooting.
3. Turn to page 3-2 as indicated.
4. Starting on page 3-3 and continuing on page 3-4, you will find the troubleshooting table 3-1 instructions that will identify and correct simple engine malfunctions. Look at item 3. **ENGINE CRANKS BUT DOES NOT START.**

TM 9-2320-387-10

Section II. TROUBLESHOOTING

3-5. GENERAL

Troubleshooting table 3-1 contains instructions that will help the operator identify and correct simple vehicle malfunctions. The table also helps the operator identify major mechanical difficulties that must be referred to unit maintenance. The listing of possible malfunctions come under major vehicle headings. They are:

- Engine
- Heating system
- Transmission
- Transfer case
- Brakes
- Wheels and tires
- Steering
- Winch
- Up-armed carrier

3-6. TROUBLESHOOTING PROCEDURES

a. Table 3-1 lists the common malfunctions which you may find during the operation or maintenance of the vehicle or their components. You should perform the tests/inspections and corrective actions in the order listed.

b. This manual cannot list all malfunctions that may occur, nor all tests or inspections and corrective actions. If a malfunction is not listed or is not corrected by listed actions, notify your supervisor.

CAUTION

Entering water too fast will cause water to splash up over head and into air intake. The engine may stop abruptly and will not crank. Do not continue starting efforts; damage to engine will result.

NOTE

- Hydraulic lock is caused by the entry of substantial amounts of water into the engine through the air intake system and subsequent compression of the fuel system. Hydraulic lock most frequently occurs during or just after fording. Water is forced into the air intake system, is drawn into the engine, and effectively "locks-up" the engine.
- Notify unit maintenance for further engine tests if you suspect hydraulic lock.

3-2

TM 9-2320-387-10

Table 3-1. Troubleshooting

MALFUNCTION TEST OR INSPECTION CORRECTIVE ACTION:	ENGINE
<p>1. ENGINE FAILS TO CRANK</p> <p>Step 1. Check to see if transmission shift lever is in P (park). If not, place lever in P (park).</p> <p>Step 2. Check battery fluid level and check battery connections for looseness, damage, or corrosion. If any of these conditions exist, notify unit maintenance.</p> <p>Step 3. Attempt to start engine (para. 2-23).</p> <p>Step 4. Other causes. Notify unit maintenance.</p>	<p>2. ENGINE CRANKS SLOWLY</p> <p>Step 1. Check battery fluid level and check battery cable connections for looseness, damage, or corrosion. If any of these conditions exist, notify unit maintenance.</p> <p>Step 2. Attempt to start engine (para. 2-23).</p> <p>Step 3. Other causes. Notify unit maintenance.</p>
<p>3. ENGINE CRANKS BUT DOES NOT START</p> <p>Step 1. Check to see if fuel gauge indicates E (empty). Fill fuel tank, and start engine.</p> <p>Step 2. Purge fuel system of air (para. 3-11).</p> <p>Step 3. Check to see if wait-to-start lamp assembly fails to light or does not go out. Notify unit maintenance if wait-to-start lamp assembly fails to light or does not go out.</p> <p>Step 4. Other causes. Notify unit maintenance.</p>	<p>3. ENGINE CRANKS BUT DOES NOT START</p> <p>Step 1. Check battery cable connections for looseness, damage, or corrosion. Notify unit maintenance of any damage to battery cables.</p> <p>Step 2. Check for broken or missing drivebelt. Notify unit maintenance if drivebelt is broken or missing.</p> <p>Step 3. Other causes. Notify unit maintenance.</p>
<p>4. VEHICLE NOT CHARGING ACCORDING TO VOLTMETER</p> <p>Step 1. Check battery cable connections for looseness, damage, or corrosion. Notify unit maintenance of any damage to battery cables.</p> <p>Step 2. Check for broken or missing drivebelt. Notify unit maintenance if drivebelt is broken or missing.</p> <p>Step 3. Other causes. Notify unit maintenance.</p>	

3-3

HOW TO USE THIS MANUAL (Cont'd)

MAINTENANCE PROCEDURES:

5. Procedures include everything you must do to accomplish a basic maintenance task.
6. Before beginning a maintenance task, familiarize yourself with the entire maintenance procedure.
7. Pay particular attention to all notes, cautions, and warnings. They are designed to assist you with your task, prevent damage to the vehicle and its components, and protect you from injury or death.
8. An exploded diagram of the component, removed from the vehicle, shows part locations, attachments, and assembly relationships.
9. Numbered callouts, found with the art and text and arranged in a clockwise pattern, will make it easier for you to identify parts and locations.
10. Examine this manual and you will discover it is easier to use when you understand its design. We hope it will encourage you to use it often.

TM 9-2320-387-10

3-22. TIRE CHAIN INSTALLATION AND REMOVAL

CAUTION

Tire chains are only used when extra traction is required and must be used as a four-wheel set. Any other combination may cause damage to the drivetrain.

a. **Tire Chain Installation.**

- (1) Spread out tire chain assembly (1) and line up with tire.
- (2) Constantly move or drive vehicle over tire chain assembly (1) until wheel is punctured at either end of chain assembly (1), allowing tire chain assembly (1) to be draped up and over tire.
- (3) Manoeuvre tire chain assembly (1) until cross-link sections are evenly spaced around tire. Secure one side of tire chain assembly (1) to tire by hooking inside fastener (2) to chain assembly (1). Tighten chain assembly (1) as much as possible.
- (4) Repeat steps 1 through 3 until all tire chain assemblies have been properly installed.
- (5) Hook and fastener (3) to chain assembly (1) and secure with locking retainer (4) to tighten chain assembly (1). Ensure as many chain links as possible lie between the sidewall head lugs (5) on both sides of tire.
- (6) Move vehicle forward a few feet and retighten chain assembly (1) to remove any slack from where tire was resting on chain assembly (1). Secure loose chain linkage to chain assembly (1) with wire or other field expedient method.

3-24

TM 9-2320-387-10

- (7) After vehicle is driven one or two miles, stop and retighten tire chains. Ensure as many chain links as possible lie between sidewall head lugs (5) on both sides of tire.
- (8) After final tightening, secure loose chain linkage to chain assembly (1) with wire or other field expedient method.
- (9) Occasionally check tire chains (1) during operations to ensure tire chains (1) have not slipped.

b. **Tire Chain Removal.**

CAUTION

Remove tire chains from tires as soon as possible after leaving area requiring their use. Prolonged use of tire chains may damage drivetrain.

- (1) Detach locking retainer (4) from fastener (2) and unhook and fastener (3) from chain assembly (1).
- (2) Unhook inside fastener (2) from chain assembly (1) and remove chain assembly (1) from tire.
- (3) Drive vehicle off chain assembly (1).
- (4) Repeat steps 1 through 3 until all tire chain assemblies (1) have been removed from tires.
- (5) Store tire chain assemblies (1).

3-25

CHAPTER 1

INTRODUCTION

Section I. GENERAL INFORMATION

1-1. SCOPE

a. This manual contains instructions for operating and servicing M1113 S250 shelter carriers and M1114 up-armored carriers.

b. The material presented here provides operators with information and procedures needed to provide the safest and most efficient operation of these vehicles. This information includes:

- (1) Operator forms and records.
- (2) Descriptions of each vehicle and its operation.
- (3) The purpose of each vehicle.
- (4) Vehicle limitations.
- (5) The function of all controls and indicators.
- (6) Operating instructions for each vehicle.
- (7) Cautions and warnings to operators regarding safety to personnel and equipment.
- (8) How and when to use special purpose kits.
- (9) Operator maintenance checks and service procedures.
- (10) Troubleshooting procedures to be followed by operators if the vehicle malfunctions.

1-2. MAINTENANCE FORMS AND RECORDS

Department of the Army forms and procedures used for equipment maintenance will be those prescribed by DA Pam 738-750, The Army Maintenance Management System (TAMMS).

1-3. HAND RECEIPT MANUAL

This operator's manual has a companion document with a TM number followed by -HR (which stands for Hand Receipt). TM 9-2320-387-10-HR consists of preprinted hand receipts (DA Form 2062) that list end item related equipment (i.e., COEI, BII, and AAL) you must account for. As an aid to property accountability, additional -HR manuals may be requisitioned from the following source in accordance with procedures in chapter 12, AR 25-30:

Commander
U.S. Army Publications Distribution Center
2800 Eastern Blvd.
Baltimore, MD 21220-2896

1-4. CORROSION PREVENTION AND CONTROL (CPC)

Corrosion Prevention and Control (CPC) of Army materiel is a continuing concern. It is important that any corrosion problems with this item be reported so that the problem can be corrected and improvements made to prevent the problem in future items. While corrosion is typically associated with rusting of metals, it can also include deterioration of other materials, such as rubber and plastic. Unusual cracking, softening, swelling, or breaking of these materials may be a corrosion problem. If a corrosion problem is identified, it can be reported using SF 368 Product Quality Deficiency Report (PQDR). Use of key words such as corrosion, rust, deterioration, or cracking will ensure that the information is identified as a CPC problem. The form should be submitted to the address specified in DA Pam 738-750.

1-5. REPORTING EQUIPMENT IMPROVEMENT RECOMMENDATIONS (EIRs)

If your vehicles need improvement, let us know. Send us an EIR. You, the user, are the only one who can tell us what you don't like about your equipment. Let us know why you don't like the design or performance. Put it on an SF 368, Product Quality Deficiency Report (PQDR). Mail it to us at: Commander, U.S. Army Tank-automotive and Armaments Command, ATTN: AMSTA-TR-Q, Warren, MI 48397-5000. We'll send you a reply.

1-6. EQUIPMENT IMPROVEMENT REPORT AND MAINTENANCE DIGEST (EIR MD)

The quarterly Equipment Improvement Report and Maintenance Digest, TB 43-0001-39 series, contains valuable field information on equipment covered in this manual. Information in TB 43-0001-39 series is compiled from some of the Equipment Improvement Reports you prepared on vehicles covered in this manual. Many of these articles result from comments, suggestions, and improvement recommendations that you submitted to the EIR program. The TB 43-0001-39 series contains information on equipment improvements, minor alterations, proposed Modification Work Orders (MWOs), warranties (if applicable), actions taken on some of your DA Form 2028s (Recommended Changes to Publications), and advance information on proposed changes that may affect this manual. The information will help you in doing your job better and will help in keeping you advised of the latest changes to this manual. Also refer to DA Pam 25-30, Consolidated Index of Army Publications and Blank Forms, and appendix A, References, of this manual.

1-7. BREAK-IN SERVICE

Upon receipt of vehicle, or after engine replacement, break-in precautions must be observed during the first 500 miles (805 kilometers) of operation. For break-in procedure, refer to paragraph 2-11.

Section II. EQUIPMENT DESCRIPTION

1-8. EQUIPMENT CHARACTERISTICS, CAPABILITIES, AND FEATURES

The 1-1/4 ton, 4x4, M1113 and M1114 vehicles are tactical vehicles designed for use over all types of roads, as well as cross-country terrain, in all weather conditions. The vehicles have four driving wheels, powered by a V-8 liquid-cooled turbocharged diesel engine. Four-wheel hydraulic service brakes and a mechanical parking brake are standard. All vehicles are equipped with a pintle hook for towing. Tiedowns and lifting eyes are provided for air, rail, or sea shipment.

1-9. METRIC SYSTEM

The equipment/system described herein contains metric components and requires metric, common, and special tools; therefore, both metric and standard units will be used throughout this publication. In addition, a metric conversion table is located on the inside back cover of this publication.

1-10. S250 SHELTER CARRIER (M1113)

a. **Purpose of Vehicle.** M1113 shelter carrier provides the capability to secure and transport the S250 electrical equipment shelter with a total payload, including crew, of 4,200 pounds (1,907 kilograms). The optional winch permits recovery operations of similar vehicles.

b. **Performance.** Fully-loaded M1113 shelter carriers will climb road grades as steep as 40% (22°) and traverse a side slope of up to 30% (17°). The vehicle fords hard bottom water crossings up to 30 inches (76 centimeters) without a deep water fording kit and 60 inches (152 centimeters) with the kit. Refer to table 1-10 for cruising range.

c. **Special Limitations.** None.

d. **Special Instructions in the Manual.**

(1) Refer to para. 2-2, Controls, Indicators, and Equipment.

(2) Refer to chapter 2, section V, S250 Shelter Carrier Operation.

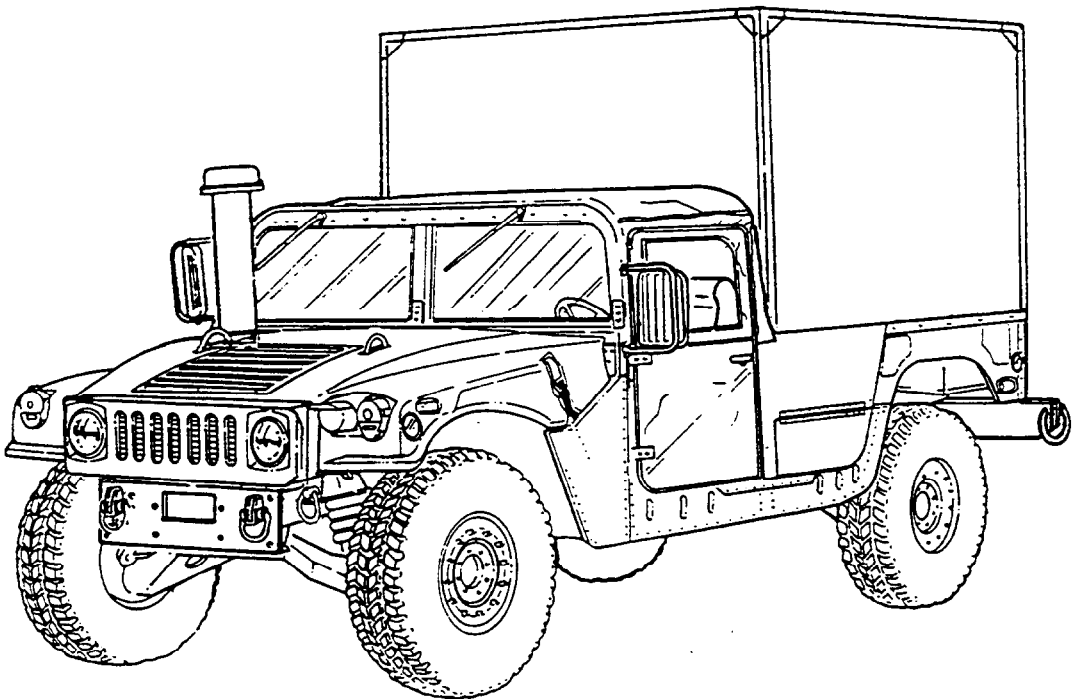

M1113

1-11. UP-ARMORED CARRIER (M1114)

- a. **Purpose of Vehicle.** The M1114 up-armored vehicle carrier provides added ballistic protection for armament components, crew, and ammunition. The optional rear winch permits recovery operations of similar vehicles.
- b. **Performance.** The M1114 up-armored vehicle carrier will climb road grades as steep as 40% (22°) and traverse a side slope of up to 30% (17°). The vehicle fords hard bottom water crossings up to 30 inches (76 centimeters). Refer to table 1-10 for cruising range.
- c. **Special Limitations.** None.
- d. **Special Instructions in the Manual.**
- (1) Refer to para. 2-2, Controls, Indicators, and Equipment.
 - (2) Refer to para. 2-33, Up-Armored Weapon Station Operation.

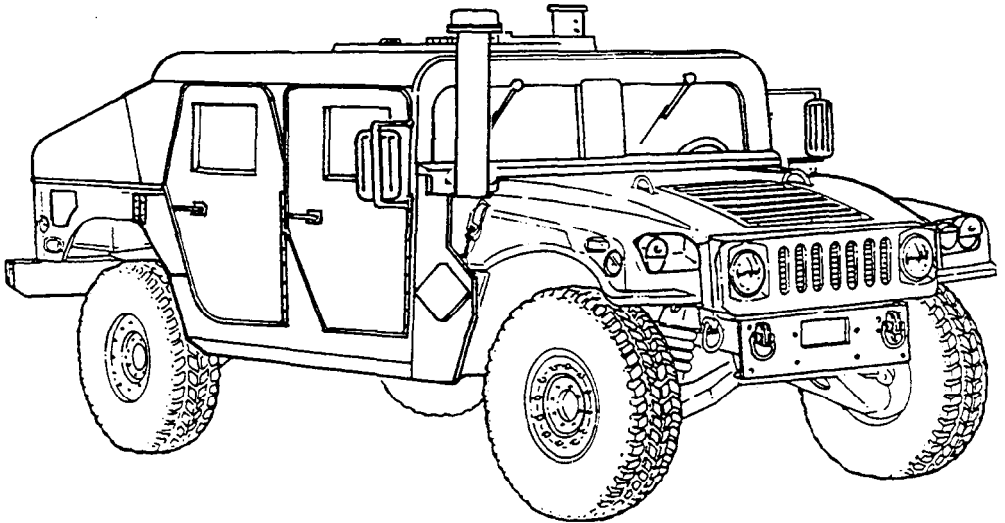

M1114

1-12. TABULATED DATA

This paragraph organizes vehicle specifications, special equipment, and model differences in table form for easy reference by operators.

Table 1-1. Differences Between Models.

Equipment/Function	Vehicle	
	M1113	M1114
Armament Mounting		X
S250 Shelter Configuration	X	
Vehicle Winch (if equipped)	X	X
Supplemental Armor		X

Table 1-2. Capacities.

Description	Capacity	
	Standard	Metric
Cooling system	27.25 qt	25.8 L
Engine (crankcase only)	7 qt	6.6 L
Engine (crankcase with new filter)	8 qt	7.6 L
Differential (each)	2 qt	1.9 L
Transmission (drain and refill)	7.7 qt	7.3 L
Transfer case	3.35 qt	3.17 L
Fuel tank	25 gal.	94.6 L
Steering system	1 qt	0.95 L
Brake master cylinder	1.12 pt	0.53 L
Total brake system	1.63 pt	0.77 L
Windshield washer	1 qt	0.95 L
Geared hub	1 pt	0.47 L

Table 1-3. General Service Data.

Description	Expected Temperatures		
	Above +15° F (above -9°C)	+40° to -15°F (+4° to -26°C)	+40° to -65°F (+4° to -54°C)
Cooling system	1/4 ethylene glycol, 3/4 water	2/5 ethylene glycol, 3/5 water	3/5 ethylene glycol, 2/5 water
Engine	OE/HDO 30	OE/HDO 10	OEA
Fuel tank	DF1, DF2	DF1	DF1, DFA*
Differentials	GO 80/90	GO 80/90	GO 75
Geared hubs	GO 80/90	GO 80/90	GO 75
Transmission	Dexron® III	Dexron® III	Dexron® III
Transfer case	Dexron® III	Dexron® III	Dexron® III
Steering system	Dexron® III	Dexron® III	Dexron® III
Brake system	Brake Fluid Silicone (BFS) .5	Brake Fluid Silicone (BFS) .5	Brake Fluid Silicone (BFS) .5
Windshield washer reservoir	1/3 cleaning compound, 2/3 water	1/2 cleaning compound, 1/2 water	2/3 cleaning compound, 1/3 water

* Use below -20°F (-29°C)

1-12. TABULATED DATA (Cont'd)

Table 1-4. Engine Data.

Type	6.5 liter diesel, turbocharged, liquid-cooled
Cylinders	8(V)
Brake horsepower	190 horsepower @ 3,400 rpm
Idle speed (engine rpm).....	700 ± 25 rpm
Operating speed (engine rpm).....	1,500-2,300 rpm
Oil pressure at idle.....	20 psi (138 kPa)
Normal operating oil pressure	40-50 psi (276-345 kPa)

Table 1-5. Cooling System Data.

Surge tank cap pressure	15 psi (103 kPa)
Thermostat:	
Starts to open	190°F (88°C)
Fully open	212°F (100°C)
Radiator	Downflow type
Fan	10 blade, 19 in. (48 cm)
Normal operating coolant temperature	190°-230°F (88°-110°C)

Table 1-6. Transmission Data.

General Information	
Model.....	Turbo Hydra-Matic 4L80-E
Type.....	Four-speed automatic
Oil type	Dexron® III
Transmission Range Selection	
Recommended Shift Lever Position	Operating Condition
P (park)	Vehicle stopped with parking brake applied.
R (reverse)	Clear of traffic and obstructions, using ground guide.
N (neutral)	Vehicle stopped with parking brake applied.
Ⓓ (overdrive)	Normal driving and fording.
D (drive)	Hilly terrain and towing a trailer.
2 (second)	Hill climbing and engine braking to slow vehicle when descending steep hills.
1 (first)	Maximum engine braking when descending very steep hills, climbing steep hills, or driving through deep mud, sand, or snow.

Table 1-7. Transfer Case Data.

General Information	
Model	New Venture Gear
Type.....	Two-speed, locking, chain-driven
Oil type.....	Dexron® III
<u>CAUTION</u>	
<p>Damage to drivetrain will occur if transfer case ranges are not selected properly. Refer to paragraph 2-13 for specific instructions on placing vehicle in motion, and to paragraph 2-40 for operating on unusual terrain.</p>	
Transfer Case Range Selection	
Recommended Shift Lever Position	Operating Condition
H (high range)	This drive range shall be selected whenever possible. High range should be used when operating on all primary, secondary, and off-road surfaces, where little or no wheel slippage exists. This range is also to be used when encountering sharp, continuous turns on high traction surfaces.
H/L (high/lock range)	This drive range shall be selected for off-highway hilly terrain or when continuous wheel slippage is evident; i.e., when operating in mud, snow, loose sand, or on ice, and increased control or additional traction is required.
L (low range)	This drive range shall be selected only when high ranges do not provide sufficient power to negotiate steep hills or downgrades. This range shall also be used when the vehicle is mired and cannot be extracted using the high/ lock range.
N (neutral)	Vehicle is disabled and must be towed.

1-12. TABULATED DATA (Cont'd)

Table 1-8. Maximum Vehicle Operating Speeds.

Transmission Range Selection	Transfer Case Range Selection		
	L (Low Range)	H (High Range)	H/L (High/Lock Range)
R (reverse)	9 mph (14 kph)	23 mph (37 kph)	9 mph (14 kph)
ⓓ (overdrive)	21 mph (34 kph)	55 mph (88 kph)	55 mph (88 kph)
D (drive)	21 mph (34 kph)	55 mph (88 kph)	55 mph (88 kph)
2 (second)	15 mph (24 kph)	40 mph (64 kph)	40 mph (64 kph)
1 (first)	9 mph (14 kph)	23 mph (37 kph)	23 mph (37 kph)

Table 1-9. Vehicle Dimensions.

Vehicle	Length Overall		Height Overall		Height Minimum Reducible	
	Inches	Centimeters	Inches	Centimeters	Inches	Centimeters
M1113	190.5	483.9	69	175	55	140
M1114	190.5	483.9	73	185	71	180
	Width Overall		Ground Clearance			
	Inches	Centimeters	Under Axle		Under Chassis	
			Inches	Centimeters	Inches	Centimeters
ALL	85	216	15	38	24	61

Table 1-10. Vehicle Cruising Range.

NOTE		
When vehicle is driven on hard surface and hilly terrain at a speed of 30-40 mph (48-64 kph), the cruising range shown for each vehicle can be expected.		
Vehicle	Gross Vehicle Weight (GVW)	Cruising Range
M1113	11,500 lb (5,221 kg)	275 mi (442 km)
M1114	12,100 lb (5,493 kg)	275 mi (442 km)

Table 1-11. 9,000 lb Winch Data.

Description	Capacities	
	Standard	Metric
Max. Load (Fifth Layer)	6,200 lb	2,812 kg
Max. Load (Fourth Layer)	7,000 lb	3,175 kg
Max. Load (Third Layer)	8,000 lb	3,629 kg
Max. Load (Second Layer)	8,500 lb	3,856 kg
Max. Load (First Layer)	9,000 lb	4,082 kg

Table 1-12. Curb Weight.

Vehicle	Curb Weight
M1113	6,100 lb (2,767 kg)
M1114	9,800 lb (4,264 kg)

Table 1-13. Vehicle Bridge Classification.

Model	Empty	Loaded	
		Cross-Country	Highway
M1113	2	4	4
M1114	3	4	4

Section III. PRINCIPLES OF OPERATION

1-13. GENERAL

This section explains components of the M1113 and M1114 vehicles. The systems (functional groups) covered are listed in the Principles of Operation Reference Index, paragraph 1-14.

1-14. PRINCIPLES OF OPERATION REFERENCE INDEX

REF. PARA.	TITLE	PAGE NO.
1-15.	Drivetrain Operation	1-14
1-16.	Fuel System Operation	1-15
1-17.	Cooling System Operation	1-16
1-18.	Starting System Operation	1-18
1-19.	Generating System Operation (200-Ampere Alternator)	1-20
1-20.	Battery System Operation	1-22
1-21.	Windshield Wiper/Washer System Operation	1-23
1-22.	Service/Parking Brake System Operation	1-24
1-23.	Service Brake System Operation	1-25
1-24.	Steering Control System Operation	1-27
1-25.	Suspension System Operation	1-29
1-26.	200-Ampere Umbilical Power Cable (M1113)	1-31

1-15. DRIVETRAIN OPERATION

The drivetrain converts horsepower into mechanical force to move the vehicle. Major components of the drivetrain are:

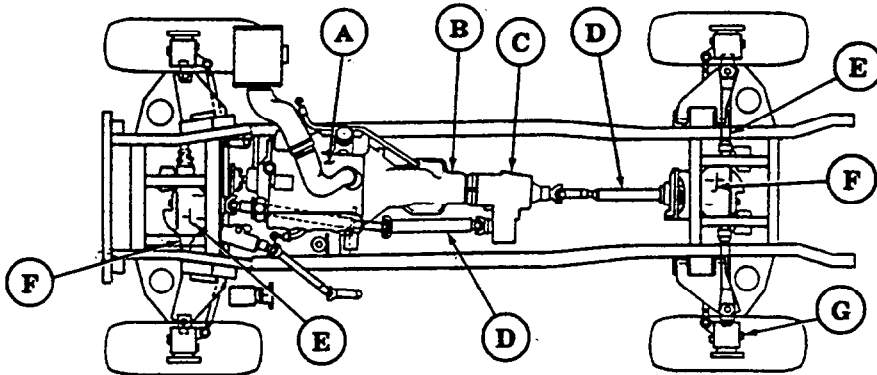

- (A) ENGINE** – The 6.5 liter V-8 turbocharged engine develops approximately 190 horsepower at 3,400 rpm. Engines equipped for deep water fording have a specially-sealed dipstick, dipstick tube, and vented CDR valve.
- (B) TRANSMISSION** – Adapts engine power to meet different driving conditions. The automatic transmission has four forward speeds, a reverse, a neutral and a park. A neutral safety switch prevents the vehicle from being started with the transmission in any selector lever position except park and neutral.
- (C) TRANSFER CASE** – Directs engine-to-transmission power to front and rear differentials simultaneously. This condition means the vehicle is always in four-wheel drive. The transfer case allows for selection of three drive ranges and a neutral position. (See table 1-7).
- (D) PROPELLER SHAFTS** – Link transfer case to differentials. Universal joints, located at either end of the front and rear propeller shafts, permit inline driving power between the transfer case and differentials even though they are mounted at different angles.
- (E) HALFSHAFTS** – Transmit power from differentials to geared hubs.
- (F) DIFFERENTIALS** – Transmit driving power, via halfshafts and geared hubs, to left and right wheels. The differential ensures power is applied to the wheel having traction. This feature is called torque biasing.
- (G) GEARED HUBS** – Serve as the front wheel steering spindle and act as the final drive components to front and rear wheels.

1-16. FUEL SYSTEM OPERATION

The diesel fuel system stores, cleans, and supplies fuel for the engine. Major components of the fuel system are:

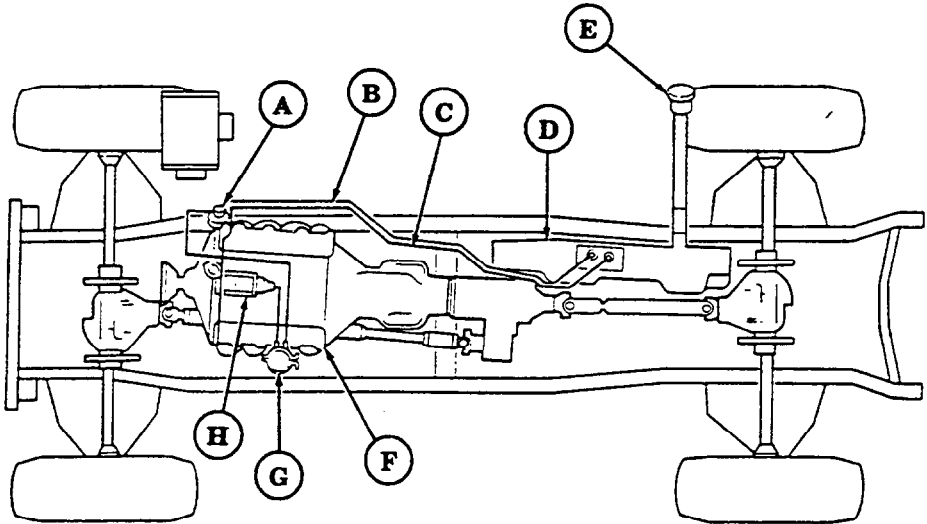

- (A) **FUEL PUMP** – Draws fuel from fuel tank through the supply line and pumps it to the fuel filter.
- (B) **FUEL RETURN LINE** – Directs unused fuel from the injection pump back to the fuel tank.
- (C) **FUEL SUPPLY LINE** – Directs fuel from fuel tank to the system.
- (D) **FUEL TANK** – Stores 25 gallons (95 liters) of diesel fuel.
- (E) **FUEL FILLER CAP** – Located at right rear side of vehicle, the cap is removed to permit fuel tank servicing.
- (F) **FUEL INJECTORS** – Receive metered fuel from the injection pump and sprays fuel into the combustion chamber.
- (G) **FUEL FILTER/WATER SEPARATOR** – Filters water and sediment from fuel before fuel enters the injection pump.
- (H) **INJECTION PUMP** – Directs metered and pressurized fuel to the eight injector nozzles. It is mounted on top of the engine under the intake manifold.

1-17. COOLING SYSTEM OPERATION

The cooling system removes excess heat from the engine, engine oil, transfer case oil, and transmission oil. Major components of the cooling system are:

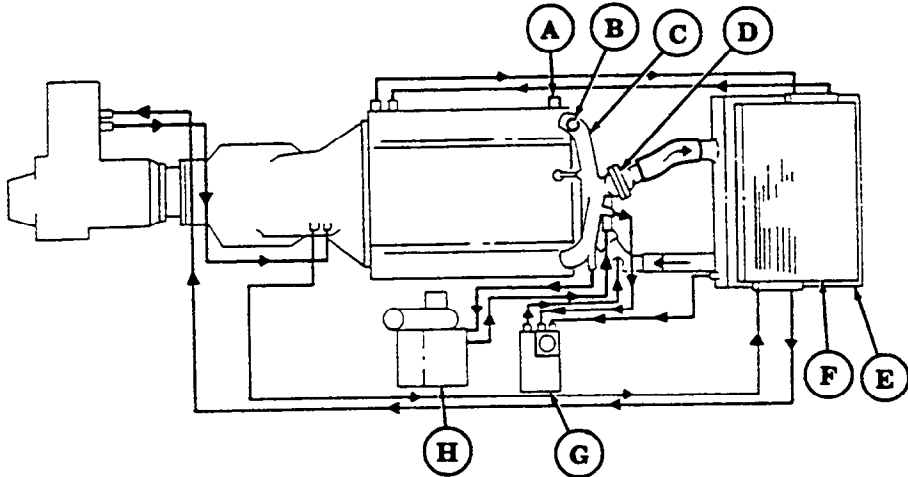

- (A) **ENGINE TEMPERATURE SENDING UNIT** – Sends signal indicating coolant temperature to gauge on instrument cluster.
- (B) **ENGINE TEMPERATURE SWITCH** – Sends signal to activate control valve system to operate fan when engine temperature exceeds 220°F (104°C) and deactivates control valve system when engine temperature drops below 190°F (88°C).
- (C) **WATER CROSSOVER** – Collects coolant from cylinder heads and channels it to the thermostat housing where it is redirected through the cooling system.
- (D) **THERMOSTAT** – Shuts off coolant return flow to radiator until temperature reaches 190°F (88°C). Coolant is then directed to the radiator through the radiator inlet hose.
- (E) **RADIATOR** – Directs coolant through a series of fins and baffles so outside air can dissipate excess engine heat before the coolant is recirculated through the engine.
- (F) **OIL COOLER** – Directs engine oil (lower half of cooler) and transmission oil (upper half of cooler) through a series of fins or baffles so outside air can remove heat from oil.
- (G) **SURGE TANK** – Filling and expansion point for cooling system.
- (H) **PERSONNEL HEATER** – Provides heat for personnel and interior of vehicle.

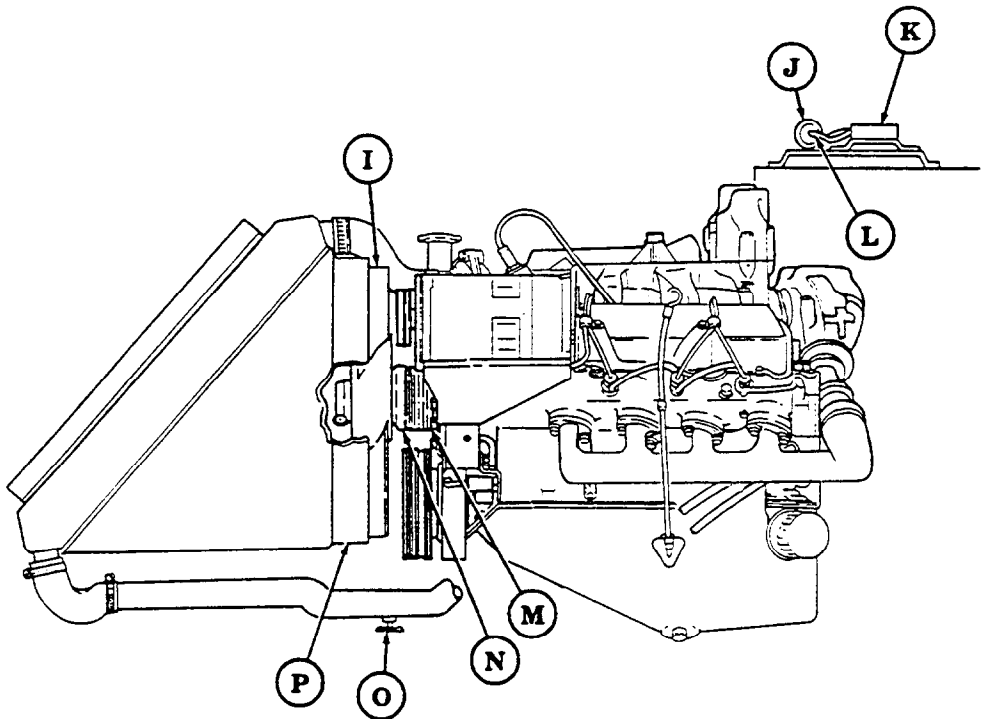

- (I) FAN** – Pulls outside air through radiator to remove heat from coolant.
- (J) HYDRAULIC CONTROL VALVE** – Directs hydraulic fluid to provide required pressure to actuate fan clutch as required by engine temperature. Hydraulic pressure supplied by power steering pump.
- (K) TIME DELAY MODULE** – Sends delayed signal to fan clutch solenoid for delay of fan actuation to provide needed horsepower for engine acceleration.
- (L) FAN CLUTCH SOLENOID** – Actuates hydraulic control valve as required by coolant temperature.
- (M) WATER PUMP** – Driven by serpentine belt, provides circulation of coolant through cooling system.
- (N) FAN CLUTCH** – Hydraulically actuated by pressure from hydraulic control valve to control operation of fan. Hydraulic pressure supplied by power steering pump.
- (O) DRAIN VALVE** – Draining point for radiator and cooling system.
- (P) RADIATOR SHROUD** – Permits a greater concentration of air to be pulled through the radiator.

1-18. STARTING SYSTEM OPERATION

The starting system consists of the following components and circuits:

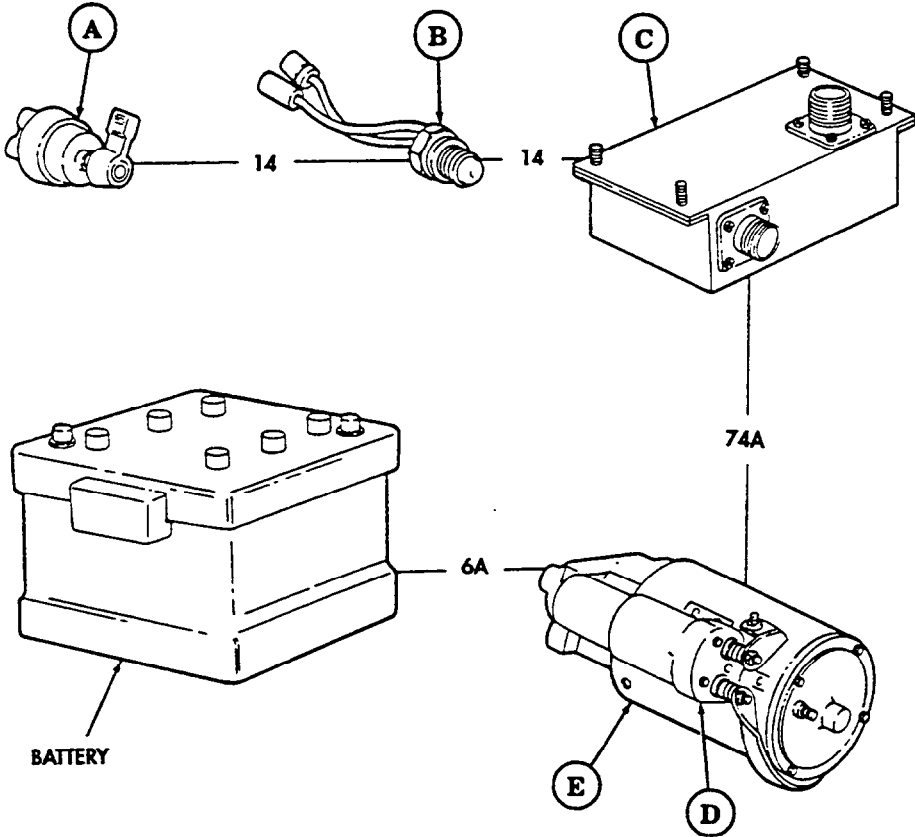

- (A) ROTARY SWITCH** – When in **START** position, provides battery power to the starter solenoid and to the neutral start switch through circuit 14.
- (B) NEUTRAL STARTER SWITCH** – When transmission shift lever is in **P** (park) or **N** (neutral) position, this switch closes, allowing battery power to reach the starter solenoid.
- (C) PROTECTIVE CONTROL BOX** – Acts as a link between body harness and engine harness.
- (D) STARTER SOLENOID** – A magnetic relay that transmits 24-volt battery power to the starter motor.
- (E) STARTER MOTOR** – Cranks the engine for starting, and is supplied 24-volt battery power through circuit 6A.

1-19. GENERATING SYSTEM OPERATION (200-AMPERE ALTERNATOR)

The 200-ampere generating system maintains battery charge and provides electrical power to operate vehicle circuits. Major components of the generating system are:

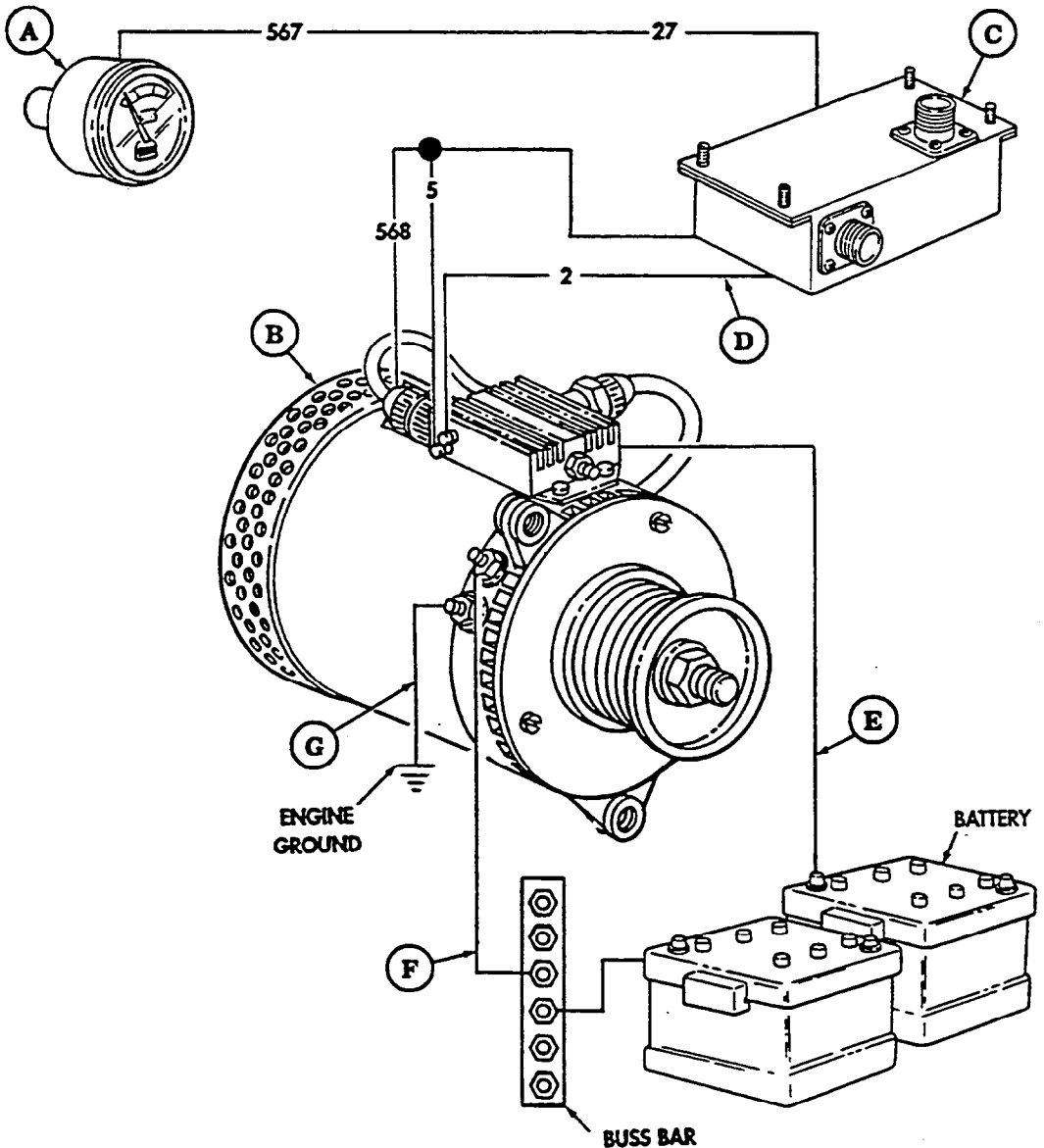

- Ⓐ **BATTERY GAUGE** – Indicates electrical system voltage. It is connected to the electrical system through circuit 567.
- Ⓑ **ALTERNATOR (200-AMPERE)** – Is a dual volt, rated at 14/28 volts, 200 amperes, with external regulator. The alternator assists and recharges vehicle batteries during operation.
- Ⓒ **PROTECTIVE CONTROL BOX** – Protects vehicle electrical system in the event battery polarity is reversed. Provides load dump, glow plug operation, and interfacing of engine and body harnesses.
- Ⓓ **CIRCUIT 2** – Sends AC signal, indicating alternator shaft rpm, to frequency switch in protective control box to prevent operation of starter solenoid when engine is running.
- Ⓔ **POSITIVE CABLE 6** – Provides 28-volt alternator output to maintain charge across two batteries.
- Ⓕ **POSITIVE CABLE 68A** – Provides 14-volt alternator output to maintain charge across the lower battery.
- Ⓖ **GROUND STRAP** – Connects negative stud on alternator with engine ground strap to provide a ground circuit to alternator.

1-20. BATTERY SYSTEM OPERATION

The battery system consists of the following circuits and components:

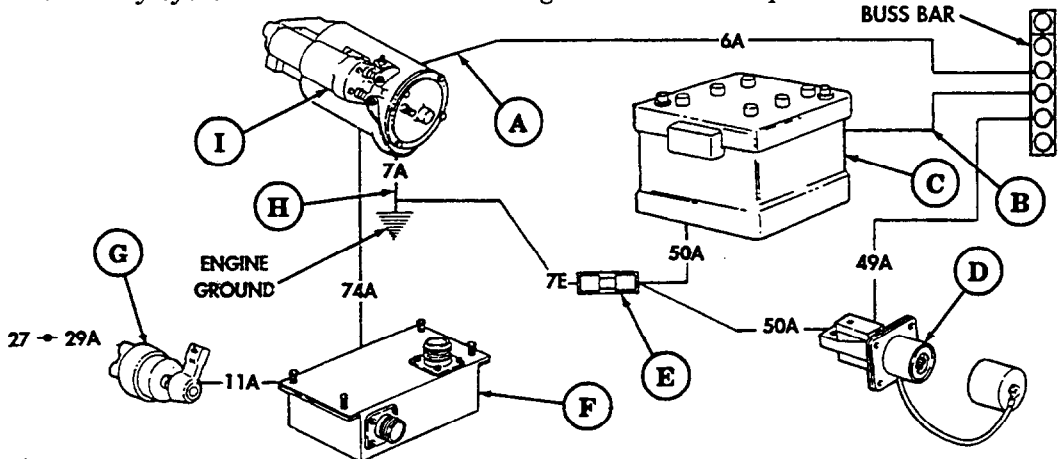

- (A) **CIRCUIT 6A** – Connects batteries (through buss bar) to starter and protective control box through circuit 74A.
- (B) **BATTERY POSITIVE CABLE** – Connects battery positive to buss bar.
- (C) **BATTERIES** – Two 6TN batteries are connected in a series to provide 24 volts DC for the electrical starting system and to assist alternator during operation.
- (D) **SLAVE RECEPTACLE** – Links an external power source directly to slaved vehicle's batteries to assist in cranking engine when vehicle's batteries are not sufficiently charged.
- (E) **SHUNT** – Used when measuring current draw from batteries utilizing STE/ICE-R.
- (F) **PROTECTIVE CONTROL BOX** – Protects vehicle electrical system in the event battery polarity is reversed. Provides frequency lockout, load dump, glow plug operation, and interfacing of engine and body harnesses.
- (G) **ROTARY SWITCH** – When in START position, actuates starter solenoid through circuits 11A and 74A. When in RUN position, closes circuit 29A to activate instrument cluster gauges through circuit 27.
- (H) **CIRCUIT 7A** – Connects starter negative circuit terminal to engine ground while 7E connects shunt to engine ground.
- (I) **STARTER SOLENOID** – Actuates starter motor gear to crank vehicle engine.

1-21. WINDSHIELD WIPER/WASHER SYSTEM OPERATION

The following miscellaneous components and circuits are not covered in any of the other electrical systems:

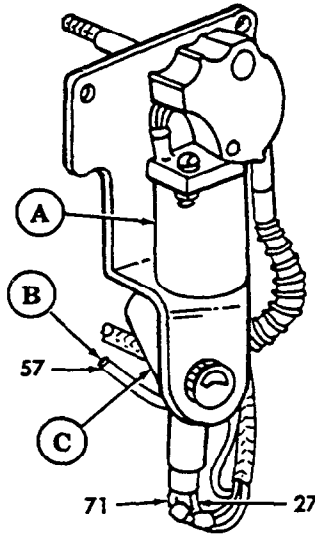

- (A) **WINDSHIELD WIPER MOTOR** – When knob is turned to LOW or HIGH position, circuit 27 carries battery power to wiper motor to activate windshield wipers.
- (B) **CIRCUIT 57** – Provides a ground circuit for wiper motor.
- (C) **WINDSHIELD WASHER MOTOR** – When knob is pushed, the washer motor is activated through circuit 71 to spray water onto windshield.

1-22. SERVICE/PARKING BRAKE SYSTEM OPERATION

The parking brake system is a mechanically-actuated system that keeps the vehicle still once it stops. It also assists in emergency stopping if there is a complete service brake system failure. Major components of the parking brake system are:

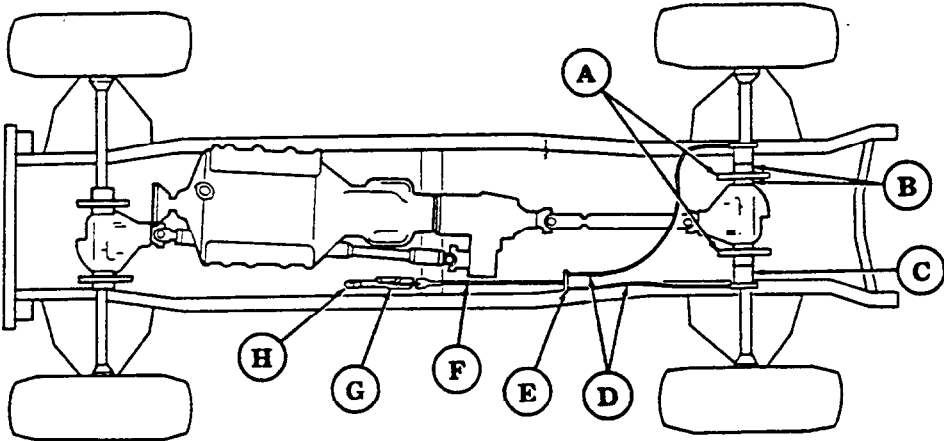

- (A) **PARKING BRAKE ROTORS** – Attached to output flanges on rear differential, rotors prevent output flanges from turning when parking brake is applied.
- (B) **BRAKE PADS** – Apply friction to rotors when hand lever is applied.
- (C) **PARKING BRAKE CALIPERS** – Force brake pads against rotors when hand lever is applied.
- (D) **PARKING BRAKE CABLES** – Connect parking brake hand lever to equalizer bar.
- (E) **EQUALIZER BAR** – Evenly distributes braking pressure to the rear brake rotors.
- (F) **PARKING BRAKE ROD** – Connects parking brake hand lever to equalizer bar.
- (G) **PARKING BRAKE HAND LEVER** – Permits operator to engage the parking brake.
- (H) **PARKING BRAKE HAND LEVER ADJUSTING CAP** – Permits operator to make minor tension adjustment of parking brake.

1-23. SERVICE BRAKE SYSTEM OPERATION

The service brake system is an inboard-mounted, four-wheel, disc brake, hydraulically-assisted system. Major components of the braking system are:

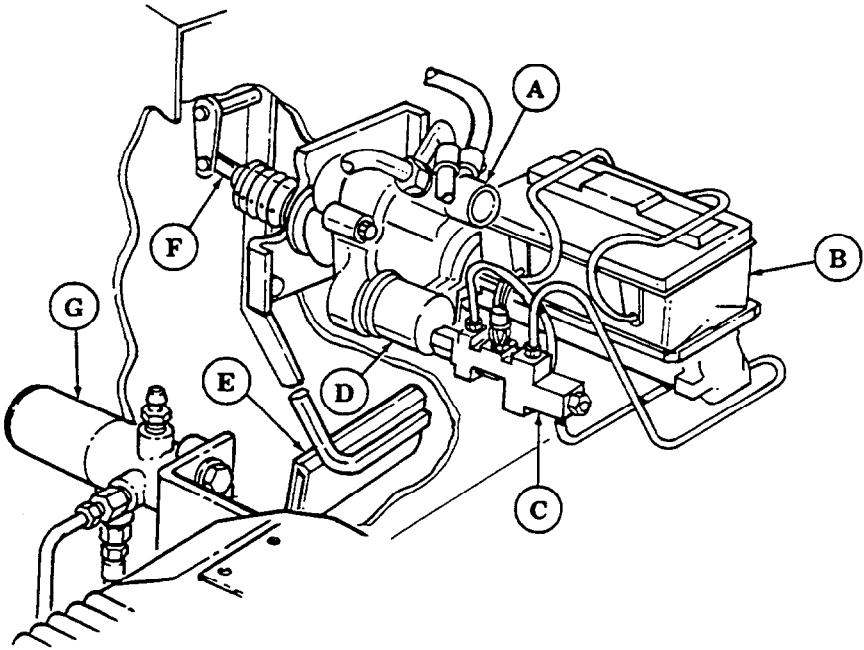

- (A) **HYDRO-BOOSTER** – Converts hydraulic power from the steering pump to mechanical power to the master cylinder, providing power assist during braking.
- (B) **MASTER CYLINDER/RESERVOIR** – Stores brake fluid, and converts mechanical pedal pressure to hydraulic pressure.
- (C) **PROPORTIONING VALVE** – Provides balanced front-to-rear braking and activates brake warning lamp in case of brake system malfunction.
- (D) **ACCUMULATOR** – Stores hydraulic pressure for additional power-assisted braking in case of loss of pressure in steering system.
- (E) **BRAKE PEDAL** – Provides operator control for stopping vehicle.
- (F) **BRAKE LINKAGE** – Directs brake pedal pressure to hydro-booster.
- (G) **BRAKE PRESSURE LIMITER** – Limits front brake line pressure to prevent brake lockup.

1-23. SERVICE BRAKE SYSTEM OPERATION (Cont'd)

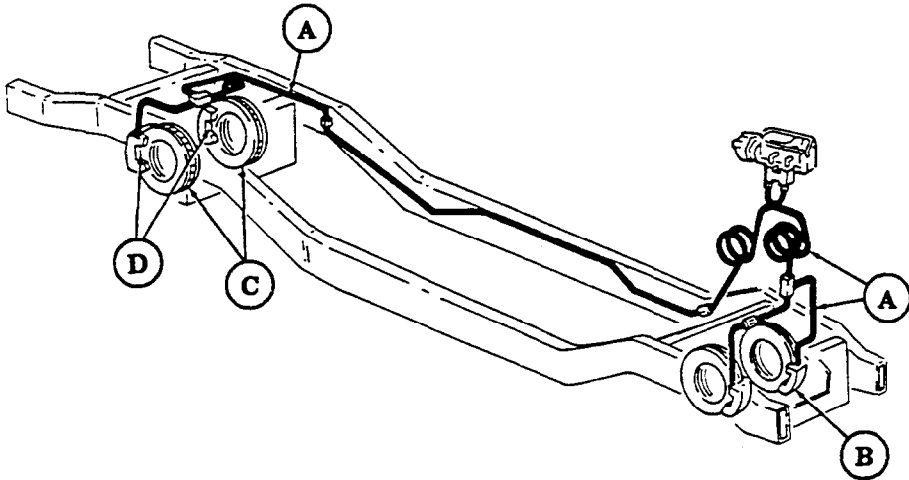

- (A) HYDRAULIC BRAKE LINES** – Direct brake fluid under pressure to all four brake calipers from master cylinder.
- (B) BRAKE CALIPER** – Converts hydraulic pressure to mechanical force to compress brake pads against brake rotors.
- (C) BRAKE ROTOR** – Attached to output flange on front and rear differentials, rotor prevents output flange from turning when brakes are applied.
- (D) BRAKE PADS** – Apply friction to brake rotor when brake pedal is depressed.

1-24. STEERING CONTROL SYSTEM OPERATION

Major components of the steering system are:

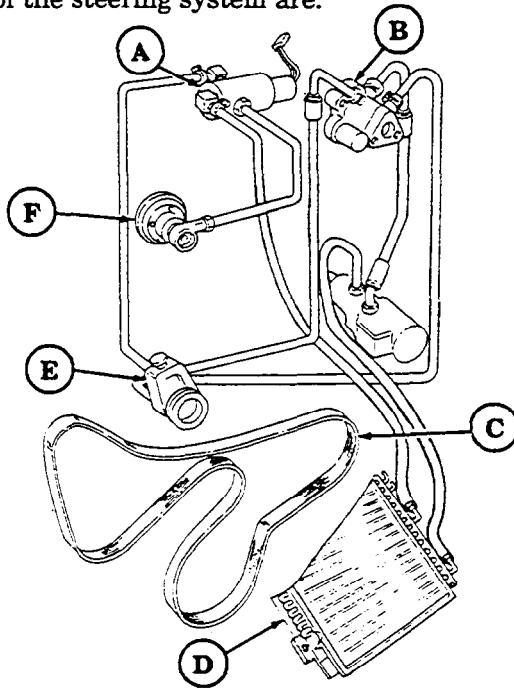

- (A) **HYDRAULIC CONTROL VALVE** – Directs hydraulic fluid to provide required pressure to actuate and deactivate fan clutch as required by engine temperature. Hydraulic pressure supplied by power steering pump.
- (B) **HYDRO-BOOSTER** – Converts hydraulic power from the steering pump to mechanical power to the master cylinder, providing power assist during braking.
- (C) **SERPENTINE BELT** – Transmits mechanical driving power from crankshaft drive pulley to steering pump pulley which drives the steering pump.
- (D) **POWER STEERING COOLER** – Directs power steering fluid through a series of fins or baffles so outside air can dissipate excess heat before the fluid is recirculated through the steering system.
- (E) **OIL RESERVOIR AND STEERING PUMP** – Combined in one unit, the reservoir serves as an oil filling point and the pump supplies the oil under pressure throughout the steering system.
- (F) **FAN CLUTCH** – Hydraulically-actuated by pressure from hydraulic control valve to control operation of fan. Hydraulic pressure is supplied by the power steering pump.

1-24. STEERING CONTROL SYSTEM OPERATION (Cont'd)

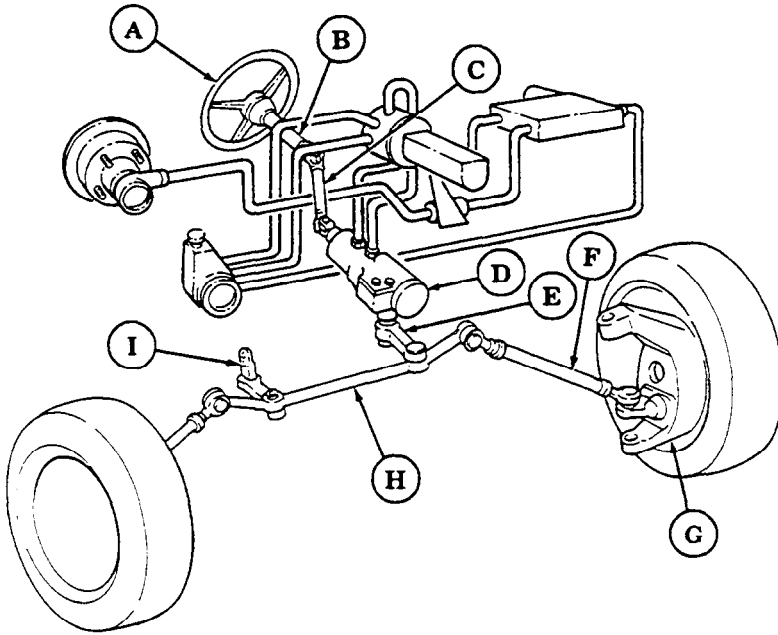

- (A) **STEERING WHEEL** – Serves as manual steering control for the operator.
- (B) **STEERING COLUMN** – Transmits turning effort from steering wheel to intermediate steering shaft.
- (C) **INTERMEDIATE STEERING SHAFT** – Permits angle of torque from steering column to input shaft of power steering gear.
- (D) **STEERING GEAR** – Converts hydraulic power from steering pump to mechanical power at pitman arm.
- (E) **PITMAN ARM** – Transfers steering torque from power steering gear to center link.
- (F) **TIE ROD ASSEMBLY** – Transmits movement from center link to geared hub.
- (G) **GEARED HUB** – Serves as the pivot point and link for the front wheels via the tie rod assembly.
- (H) **CENTER LINK** – Transmits movement from pitman arm to tie rods.
- (I) **IDLER ARM** – Supports right side of center link.

1-25. SUSPENSION SYSTEM OPERATION

The suspension system is an independent coil spring-type system. Major components of the suspension system are:

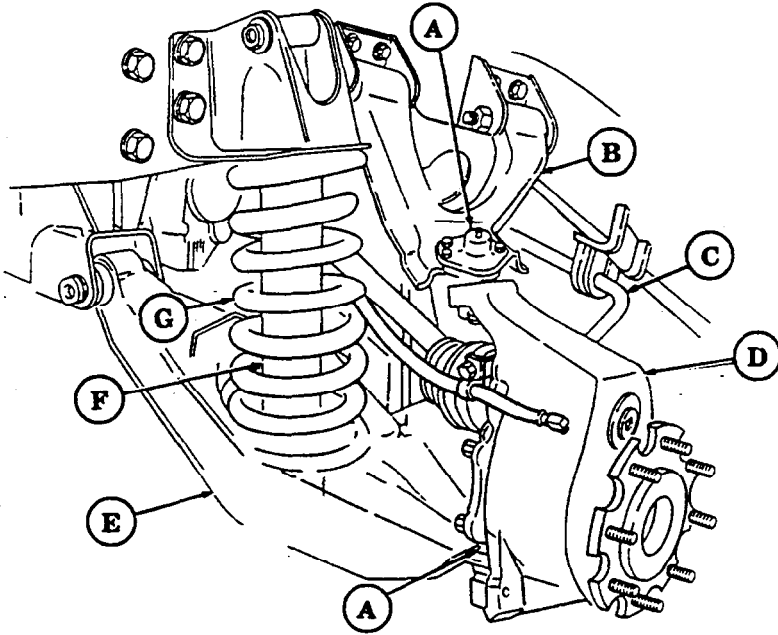

- (A) **BALL JOINTS** – Connect geared hub to control arms, and allow change of angle between geared hub and control arms during suspension movement.
- (B) **UPPER CONTROL ARM** – Connects geared hub to frame rail.
- (C) **STABILIZER BAR (FRONT ONLY)** – Prevents vehicle sway when cornering.
- (D) **GEARED HUB** – Serves as a mounting point for wheel and tire assembly and provides 1.92:1 gear reduction to increase torque to wheel and tire assembly.
- (E) **LOWER CONTROL ARM** – Connects geared hub to crossmember.
- (F) **SHOCK ABSORBER** – Dampens suspension movement and limits amount of suspension travel.
- (G) **COIL SPRING** – Supports weight of vehicle and allows suspension travel to vary depending on terrain and vehicle loading.

1-25. SUSPENSION SYSTEM OPERATION (Cont'd)

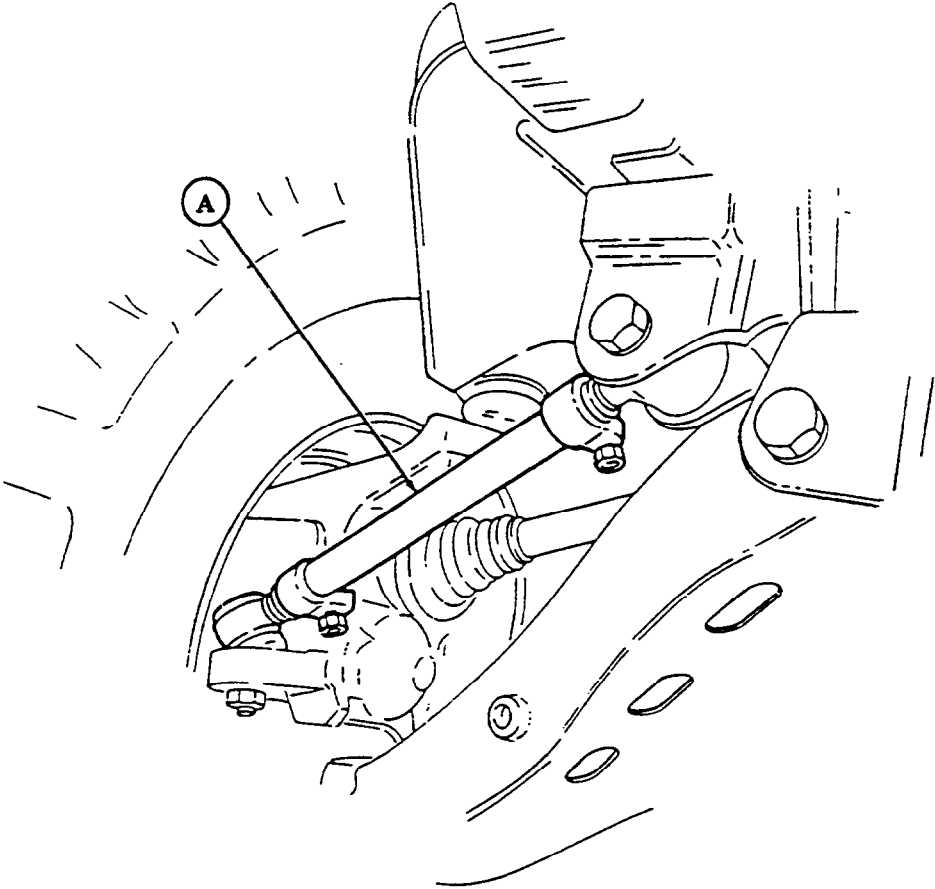

A RADIUS ROD (REAR ONLY) – Connects geared hub to frame to maintain rear end alignment.

1-26. 200-AMPERE UMBILICAL POWER CABLE (M1113)

The 200-ampere umbilical power cable covered in this manual consists of the following major component:

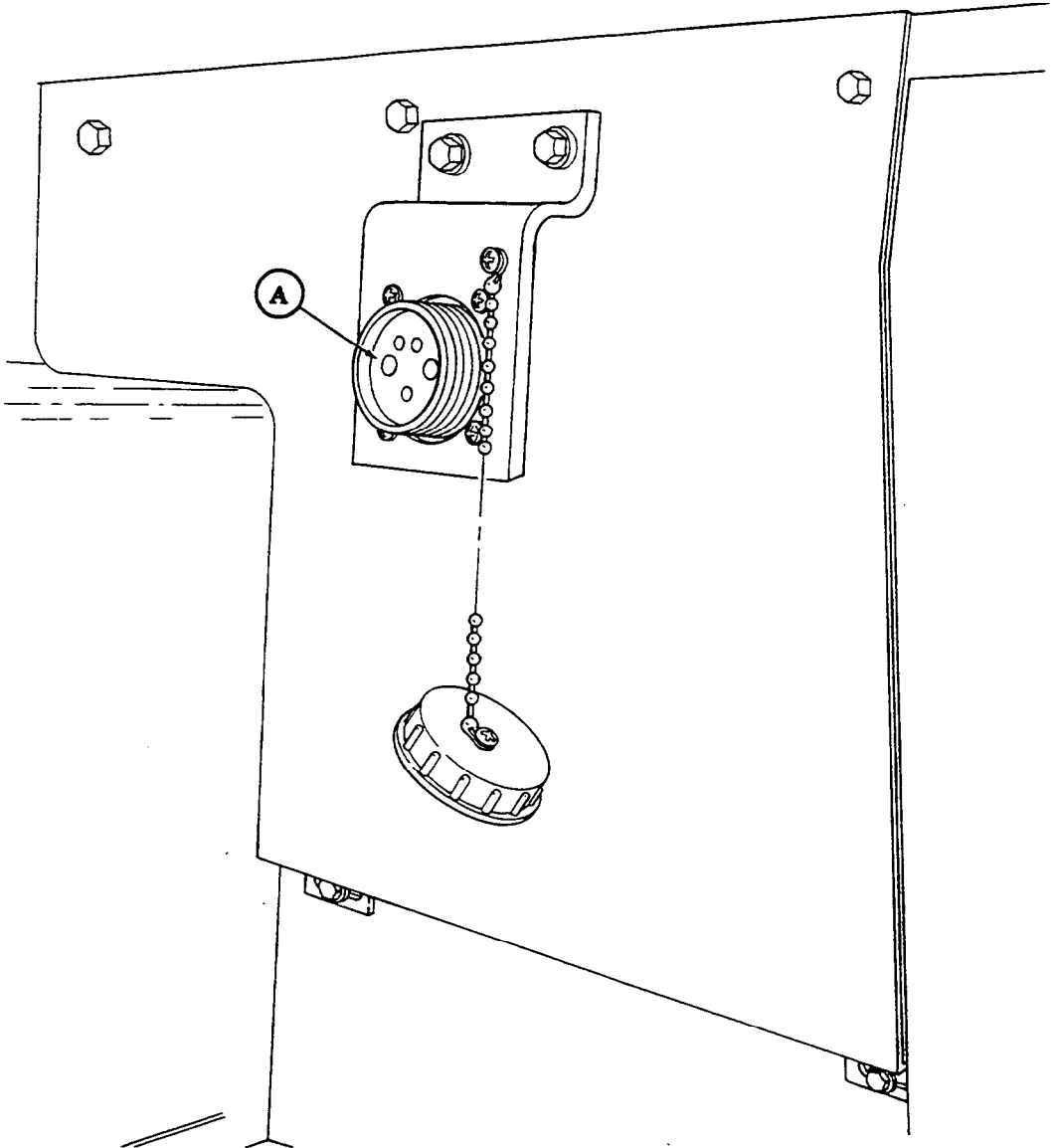

- A** **POWER CABLE** – Located behind the companion seat, provides power for shelter equipment.

CHAPTER 2 OPERATING INSTRUCTIONS

Section I. DESCRIPTION AND USE OF OPERATOR'S CONTROLS AND INDICATORS

2-1. KNOW YOUR CONTROLS AND INDICATORS

Before you attempt to operate your equipment, make sure you are familiar with the location and function of all controls and indicators. The location and function of controls and indicators are described in this section.

WARNING

- This vehicle has been designed to operate safely and efficiently within the limits specified in this TM. Operation beyond these limits is prohibited IAW AR 70-1 without written approval from the Commander, U.S. Army Tank-automotive and Armaments Command, ATTN: AMSTA-CM-S, Warren, MI 48397-5000.
- Do not use hand throttle as an automatic speed or cruise control. The hand throttle does not automatically disengage when brake is applied, resulting in increased stopping distances and possible hazardous and unsafe operation. Injury to personnel or damage to equipment may result.

NOTE

- Except where noted, the controls and indicators in this section are applicable to both vehicle models covered in this manual.
- In this manual, left side indicates the driver's side of the vehicle. Right side indicates the opposite side of the vehicle.

2-2. CONTROLS, INDICATORS, AND EQUIPMENT

a. Driver's Compartment.

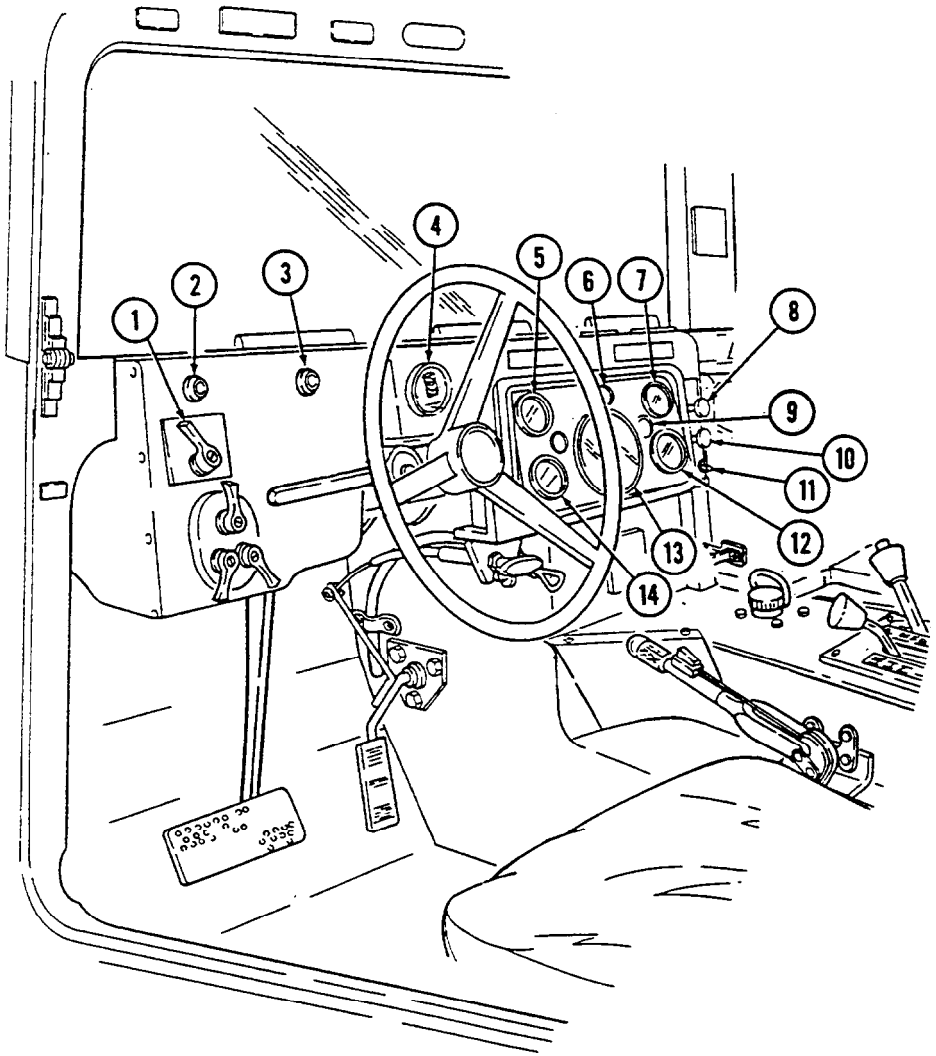

KEY ITEM AND FUNCTION

- 1 *Rotary switch* has ENG STOP, RUN, and START positions. When positioned to RUN, glow plugs are activated to heat engine precombustion chambers. When positioned to START, starter will engage and crank engine.
- 2 *Wait-to-start lamp assembly* illuminates when glow plugs are activated; goes out when engine is ready to be started.
- 3 *Brake warning lamp assembly* illuminates if parking brake is applied or if a hydraulic imbalance (leak, etc.) exists between the front and rear brake systems.
- 4 *Air restriction gauge* signals the operator that a restriction exists in the air cleaner.
- 5 *Engine oil pressure gauge* indicates oil pressure when engine is running.
- 6 *High beam lamp assembly* illuminates when front headlights are switched to HIGH beam position.
- 7 *Coolant temperature gauge* indicates engine coolant temperature.
- 8 *Defroster control knob* directs heated air to windshield on the M1113. For the M1114, control knob directs outside air in for circulation.
- 9 *Instrument panel lights* illuminate instrument panel gauges.
- 10 *Heater control knob* varies temperature of heated air into vehicle.
- 11 *Heater fan switch* controls blower motor speed. The switch has HI (high), OFF, and LO (low) settings to regulate defroster and heater air flow into vehicle.
- 12 *Voltmeter* indicates the charging level and activity of the battery charging system.
- 13 *Speedometer/odometer* indicates vehicle speed and accumulated mileage.
- 14 *Fuel gauge* indicates amount of fuel in fuel tank.

2-2. CONTROLS, INDICATORS, AND EQUIPMENT (Cont'd)

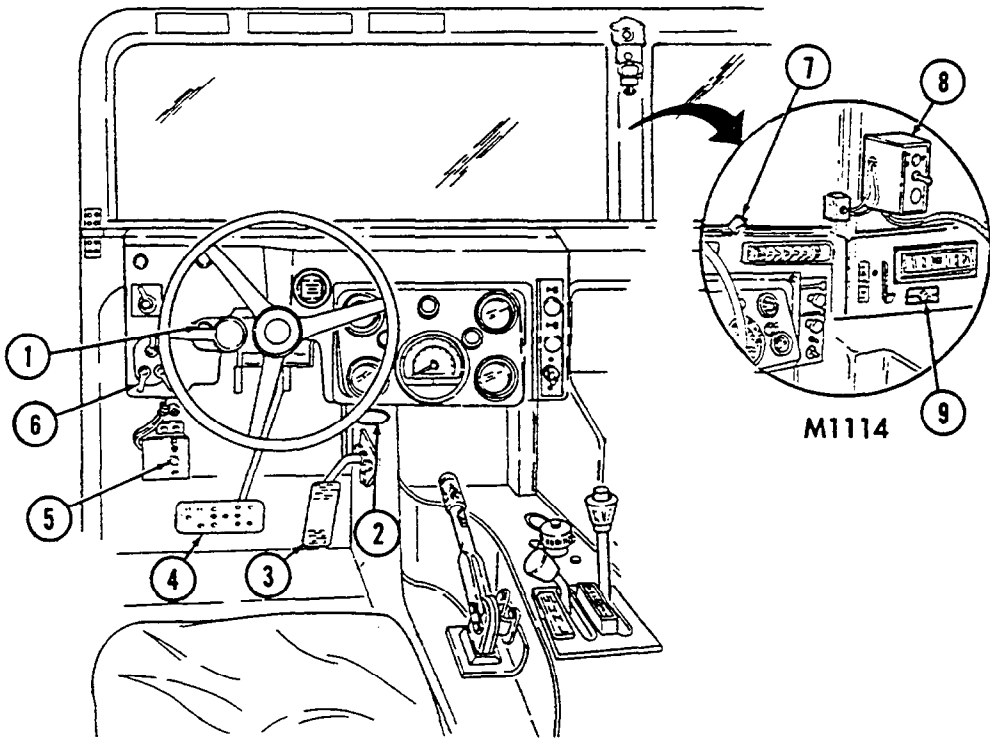

KEY ITEM AND FUNCTION

- 1 *Directional signal / emergency flasher indicator light* illuminates during directional signal or emergency flasher use.
- 2 *Hand throttle* increases engine speed for use during cold weather starting, winch operation, deep water fording, and to obtain maximum alternator output for communications/electrical requirements; is not to be used as an automatic speed or cruise control.
- 3 *Accelerator pedal* is the operator's foot control for varying engine speed.
- 4 *Service brake pedal* is depressed to slow or stop vehicle.
- 5 *Dimmer switch* permits the operator to select high or low headlight beam.
- 6 *Light switch* controls operation of vehicle service lights and blackout lights.

NOTE

Items 7 through 9 apply to the M1114 vehicle only.

- 7 *Defroster register* opens and closes the defroster to direct heated air to windshield for defrosting.
- 8 *Windshield de-icer switch* operates the windshield de-icer by moving the switch to on or off position.
- 9 *Air conditioner on / off switch* turns the air conditioner on and off.

2-2. CONTROLS, INDICATORS, AND EQUIPMENT (Cont'd)

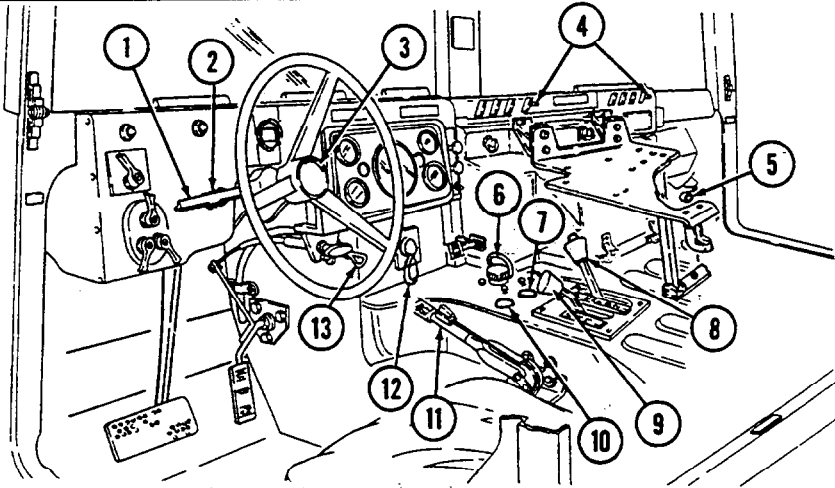

KEY ITEM AND FUNCTION

- 1 *Directional signal lever* activates turn signal lights.
- 2 *Warning hazard control* activates the warning flashers.
- 3 *Horn button* activates vehicle horn.
- 4 *Baffle operating rods* slide open to allow heated air into crew compartment.
- 5 *Fresh air intake lever* is pulled back to allow fresh air into crew compartment, or pushed forward to close.
- 6 *Simplified Test Equipment/Internal Combustion Engine-Reprogrammable (STE/ICE-R) diagnostic connector* is attaching point for the Vehicle Test Meter (VTM) to facilitate vehicle electrical and engine systems diagnoses.
- 7 *Transmission indicator lamp* comes on when ignition switch is turned on, and goes off when vehicle is started. It is used to flash the diagnostic trouble codes when the Transmission Control Module (TCM) is placed in the diagnostic mode.
- 8 *Transmission shift lever* is used to select vehicle driving range, P (park), R (reverse), N (neutral), **D** (overdrive), D (drive), 2 (second), and 1 (first).
- 9 *Transfer case shift lever* is used to select vehicle driving range, H/L (high/lock range), H (high range), N (neutral), and L (low range).
- 10 *Transfer case indicator lamp* illuminates when transfer case has completed the low-range shift and high/lock-range shift.
- 11 *Parking brake lever* is used to apply parking brake. Safety release button must be depressed to release parking brake.
- 12 *Fording control switch (M1113)* (deep water fording kit only) allows operator to select VENT during normal operating conditions or DEEP FORD for deep water fording.
- 13 *Steering wheel lock cable* permits steering wheel to be locked to prevent unauthorized use of vehicle.

KEY ITEM AND FUNCTION

- 14 *Windshield washer/wiper control knob* operates a two-speed electric wiper motor; when depressed, operates windshield washer.

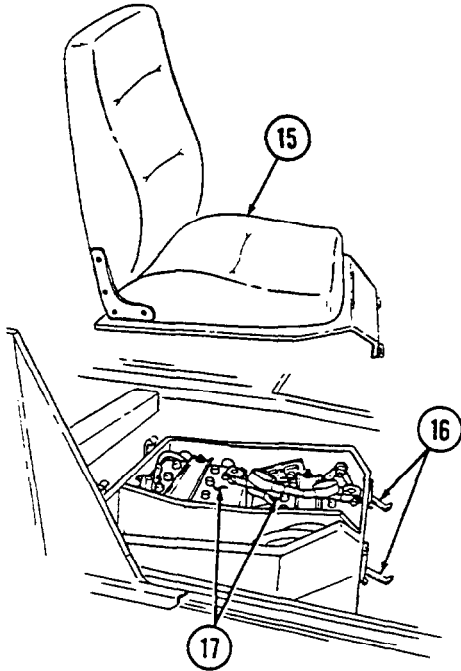
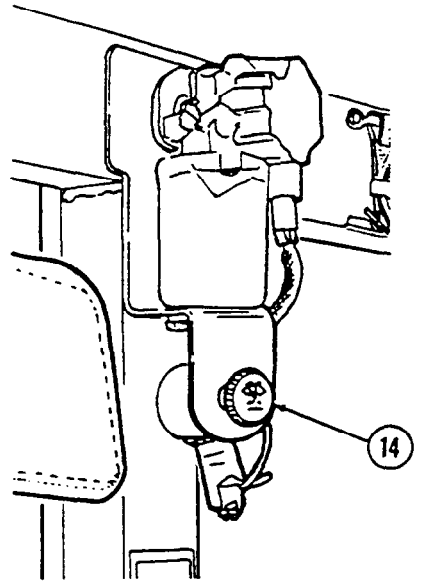

- 15 *Companion seat* is removed to provide access to batteries.
- 16 *Battery box latches* release to permit removal of companion seat for access to batteries.
- 17 *Batteries* provide 24-volt power to vehicle electrical system.

- 18 *Slave receptacle* is located at outside front of battery box. It is the connecting point for the slave cable for slave-starting the vehicle.

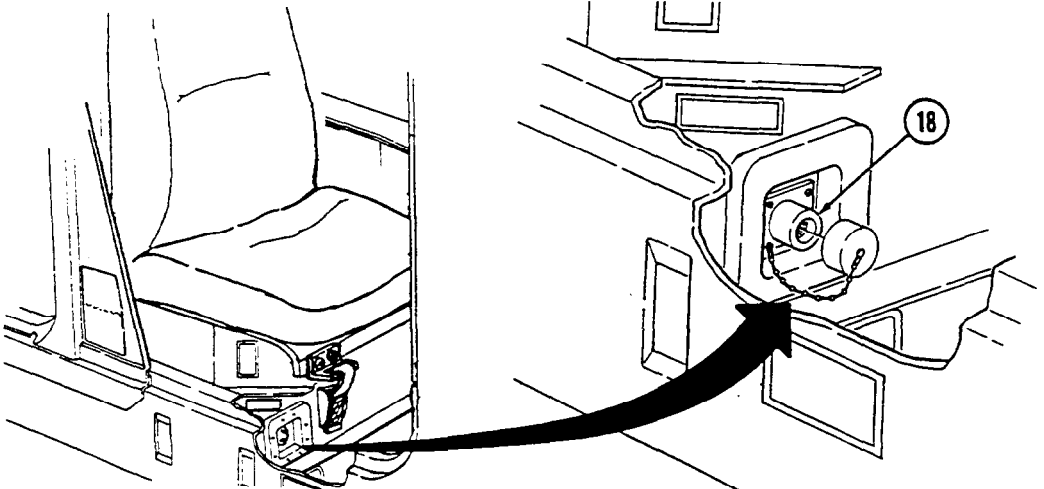

2-2. CONTROLS, INDICATORS, AND EQUIPMENT (Cont'd)

KEY ITEM AND FUNCTION

- 1 *Engine access cover is removed to provide access to rear of engine.*
- 2 *Radio rack serves as mounting point for AN/GRC-121.3 or AN/VRC-91 radio.*

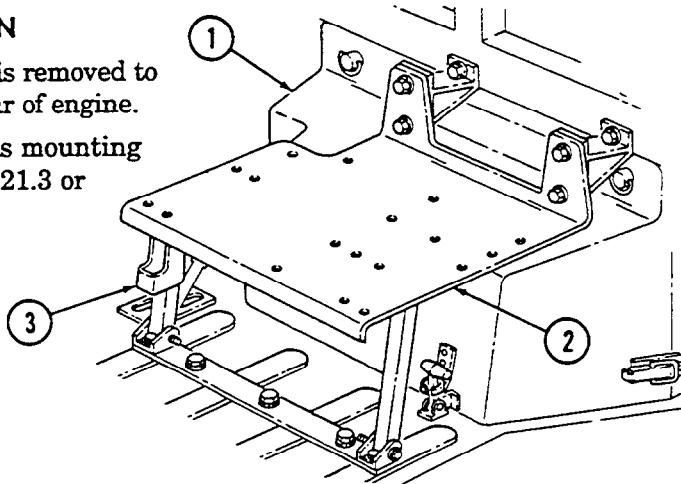

- 3 *Microphone bracket serves as mounting point for microphone.*
- 4 *Catch assembly holds M16A2 rifle safely in place for travel. Adjustable catch assembly configuration holds M16A2 rifle when positioned all the way in, or M203 grenade launcher when extended out.*
- 5 *Stock brace holds stock end of M16A2 rifle or M203 grenade launcher in position for travel.*
- 6 *Driver's seat adjusters permit driver's seat to be adjusted in forward, rearward, up, or lower positions.*
- 7 *First aid kit is located on side of front passenger seat for M1114 and for M1113 is located by driver's seat and is used for crew emergency first aid treatment.*
- 8 *Fire extinguisher is located on the side of the driver's seat.*

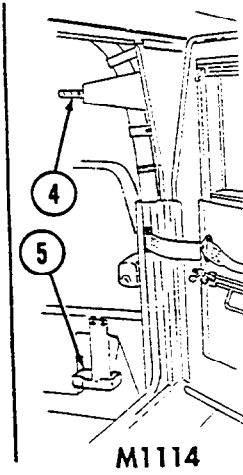
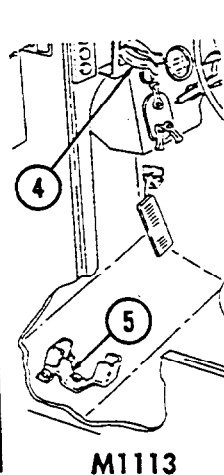
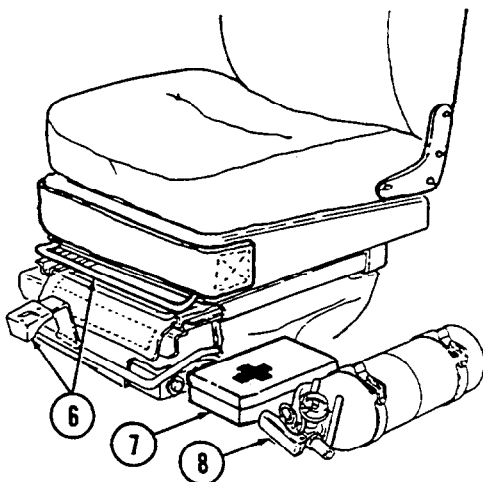

b. Engine Compartment.

KEY ITEM AND FUNCTION

- 9 *Transmission oil dipstick* is located right rear of engine; removed to check transmission fluid level.

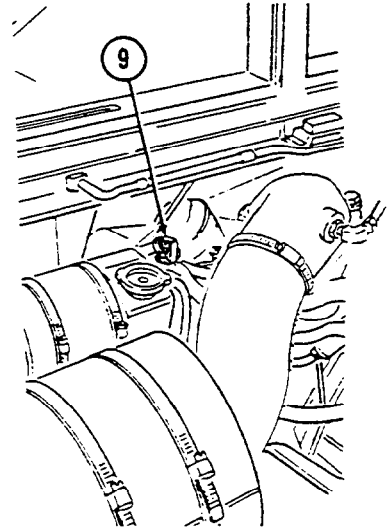

- 10 *Transmission oil dipstick tube* (located right rear of engine) is fill point for transmission fluid.

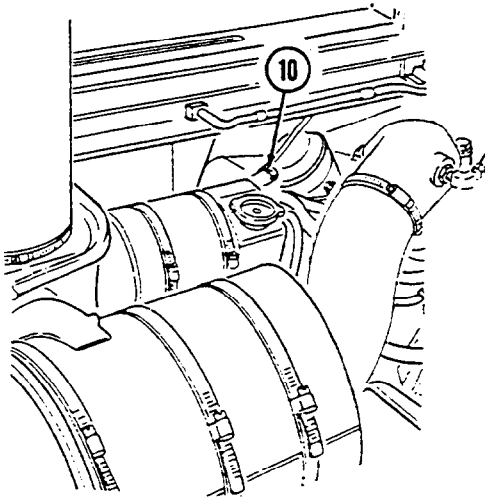

- 11 *Power steering fluid reservoir cap/dipstick* (located left front of engine) is removed to fill and/or check power steering fluid level.

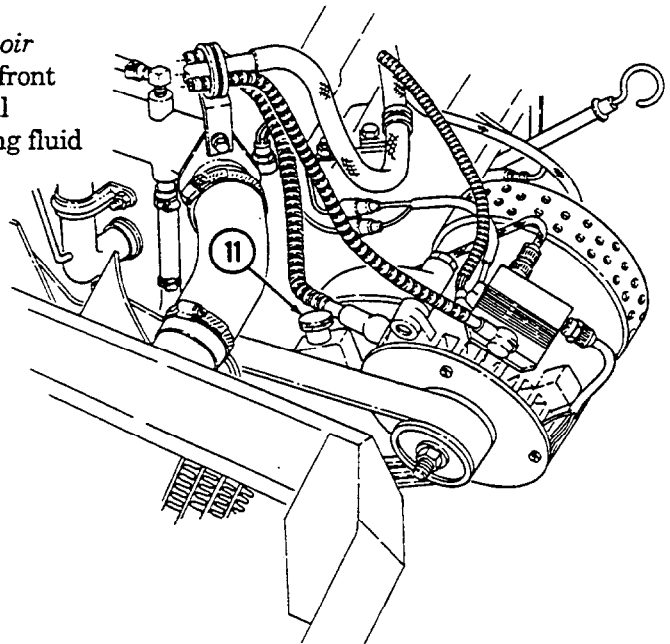

2-2. CONTROLS, INDICATORS, AND EQUIPMENT (Cont'd)

KEY ITEM AND FUNCTION

- 1 *Engine oil filler cap* (located front center of engine) is removed from oil filler neck to add oil to engine.

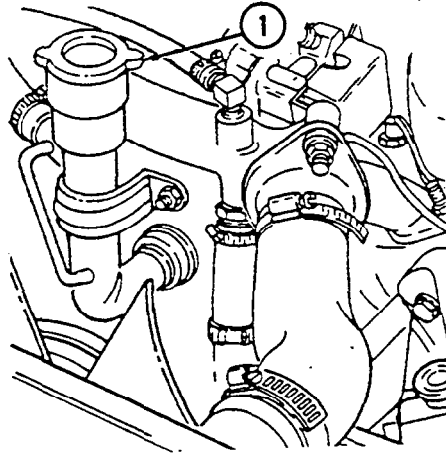

- 2 *Engine oil dipstick* is located behind alternator on left side of engine; is removed to check engine oil level.

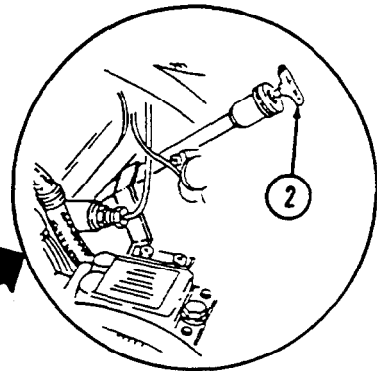
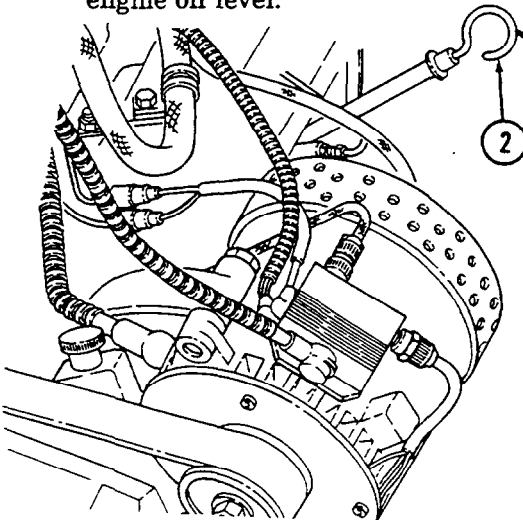

M1113 VEHICLES WITH DEEP WATER FORDING KIT

KEY ITEM AND FUNCTION

- 3 *Radiator drainvalve* (located beneath right front of engine on lower radiator crossover pipe) is turned counterclockwise to drain coolant from radiator.

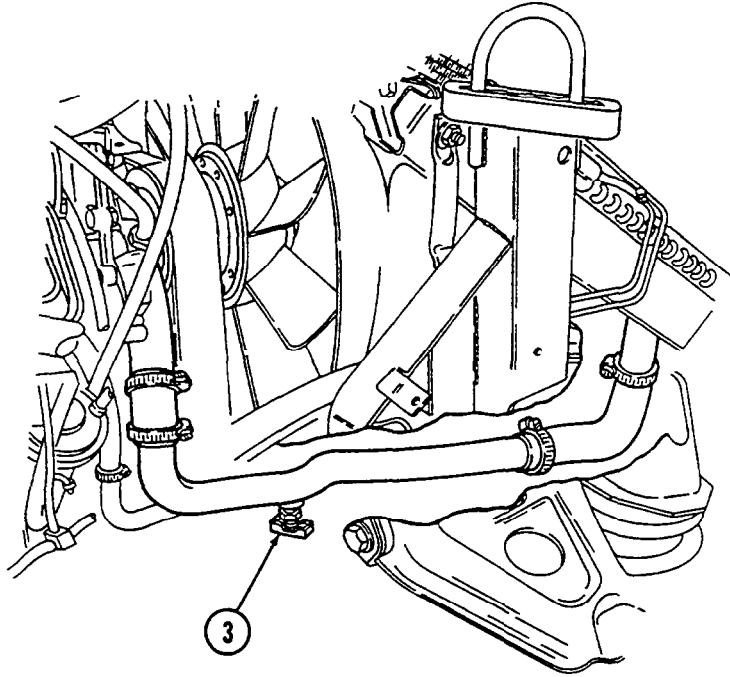

- 4 *Coolant surge tank cap* (located right rear of engine) is removed from surge tank to add coolant to cooling system.

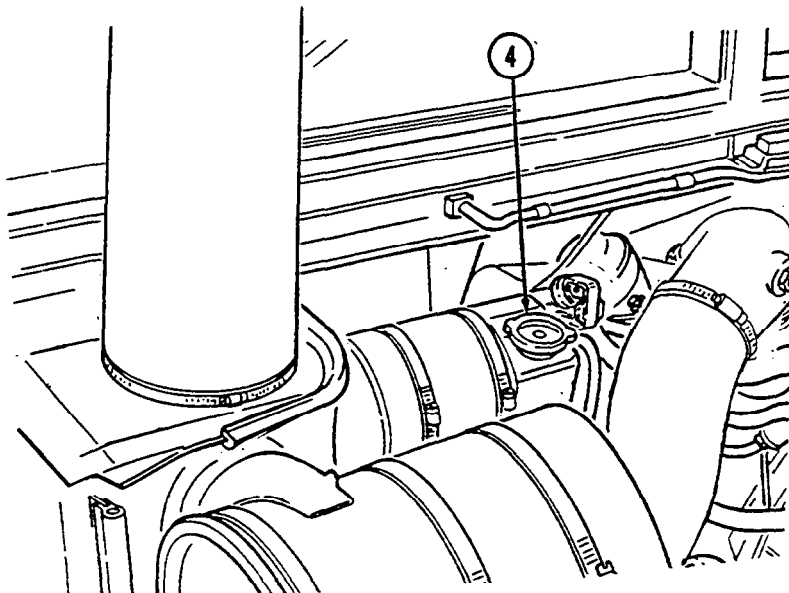

2-2. CONTROLS, INDICATORS, AND EQUIPMENT (Cont'd)

KEY ITEM AND FUNCTION

- 1 *Fuel filter* (located left rear of engine on firewall) filters water from fuel system.
- 2 *Windshield washer reservoir cap* (located left rear of engine) unsnaps to add windshield washer fluid to reservoir.
- 3 *Fuel filter drainvalve* (located left rear of engine compartment on cowl, beneath and in front of windshield washer reservoir) is draining point for water collected in fuel filter.
- 4 *Master cylinder cover* (located left of engine) is removed to fill and/or check brake fluid level.

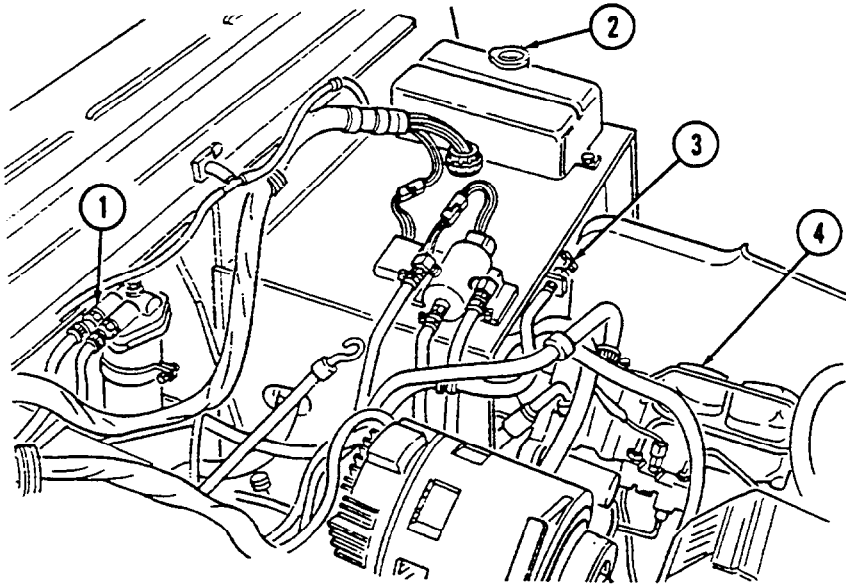

- 5 *Air cleaner assembly* (located right rear of engine) houses air cleaner element which filters dirt and dust from air before it enters combustion chamber.
- 6 *Air cleaner dump valve*, when squeezed, releases dirt, mud, or water from air cleaner body assembly.

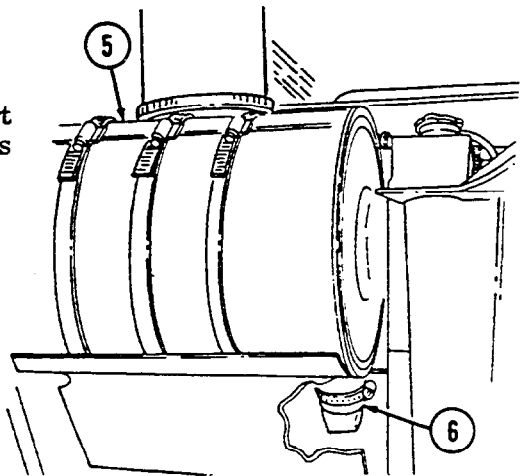

c. Vehicle Exterior.

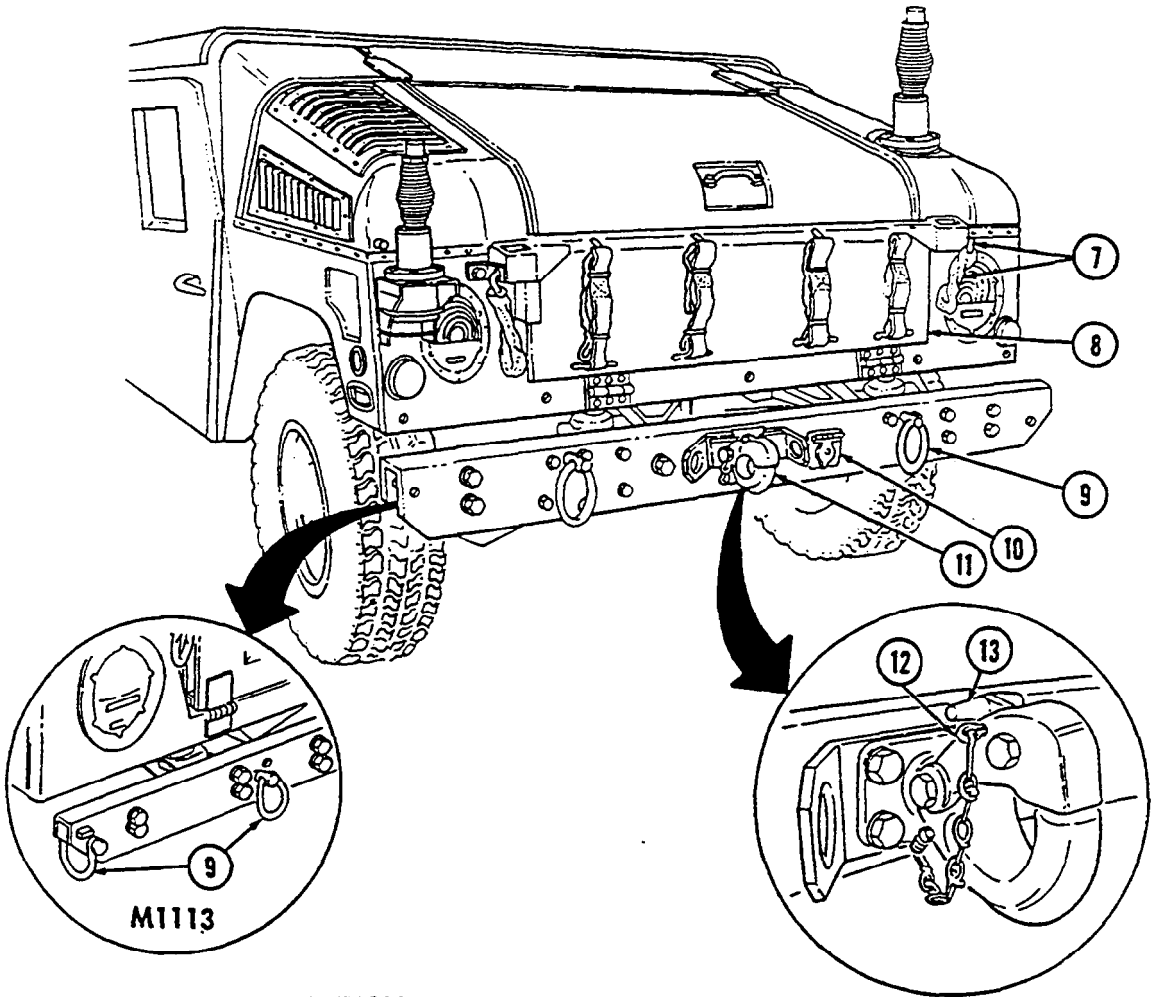

KEY ITEM AND FUNCTION

- 7 *Tailgate chains and hooks* secure tailgate to rear of vehicle body.
- 8 *Tailgate* opens and closes to allow access to vehicle cargo area.
- 9 *Lifting shackles* (located at front and rear of vehicle) are used to lift or tie down vehicle.
- 10 *Trailer receptacle* provides electrical power for towed equipment.
- 11 *Towing pintle* (rear bumper) provides connection point for towing.
- 12 *Pintle pin* locks pintle latch to towing pintle.
- 13 *Pintle latch* pulls up to open towing pintle; pushes down to lock towing pintle.

2-2. CONTROLS, INDICATORS, AND EQUIPMENT (Cont'd)

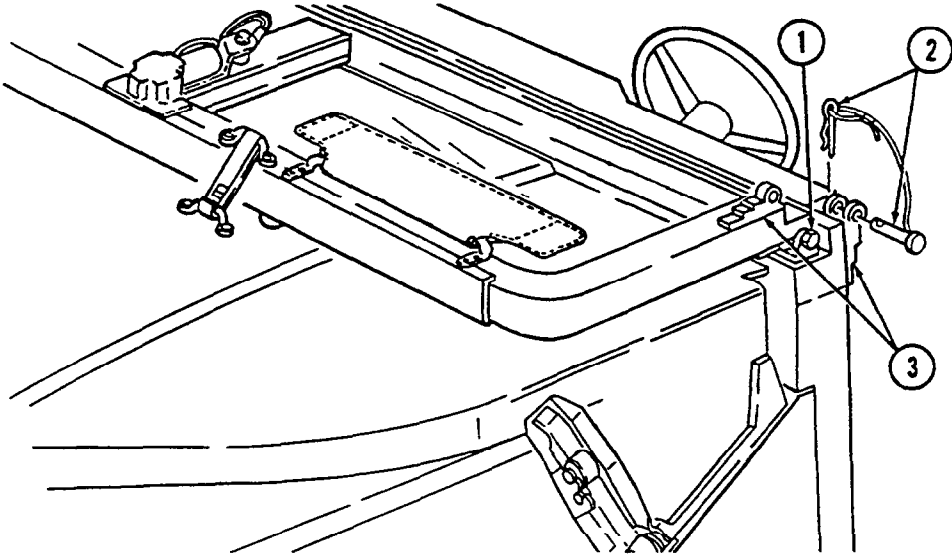

KEY ITEM AND FUNCTION

- 1 *Windshield folddown hinges (M1113)* are used as a hinge point when lowering windshield. Hinge pins are removed when detaching windshield assembly.
- 2 *Hitch pin and hinge pin (M1113)* are removed to allow windshield to be lowered or detached.
- 3 *Windshield hinges (M1113)* secure windshield in the raised (up) position with hinge pins installed. Hinge pins are removed when lowering or detaching windshield.
- 4 *Fuel tank filler cap (located at right rear side of vehicle)* is removed to permit fuel servicing.
- 5 *Fuel tank door cover (M1114)* (located at right rear side of vehicle) covers fuel tank filler cap.

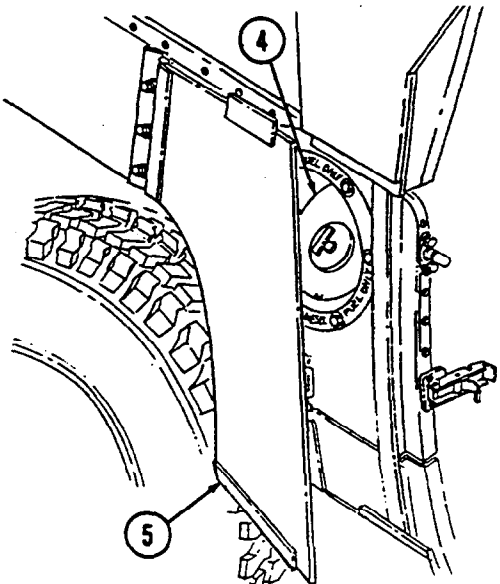

KEY ITEM AND FUNCTION

- 6 *Hood latches (one on each side of hood) unlatch to release hood.*

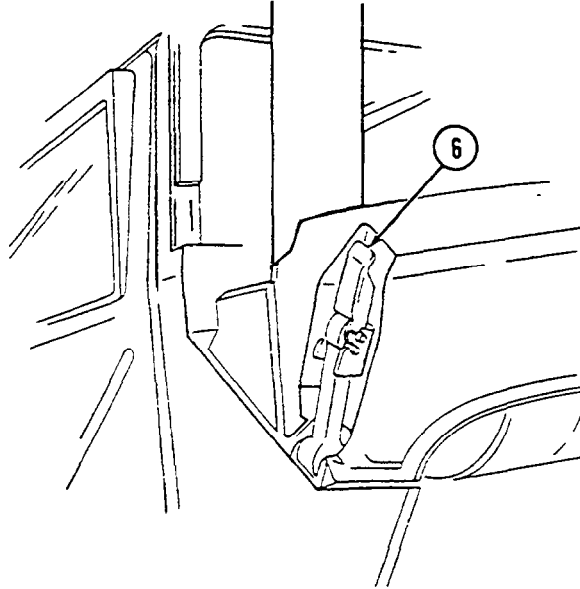

- 7 *Hood support rod (on left side of vehicle) supports hood in the raised position.*

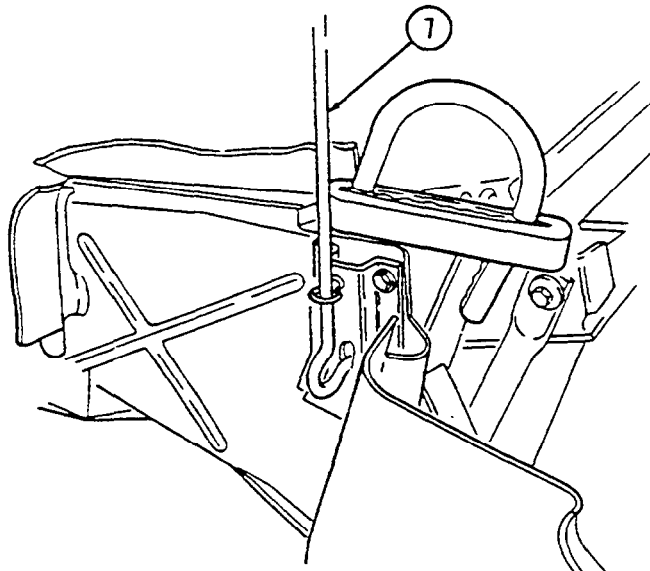

2-2. CONTROLS, INDICATORS, AND EQUIPMENT (Cont'd)

WARNING

Do not attempt to operate cargo shell door forward latch. The cargo shell door is not to be opened from inside the vehicle. Opening cargo shell door from inside the vehicle may cause damage to equipment or injury to personnel.

KEY ITEM AND FUNCTION

NOTE

Items 1 through 7 are applicable to M1114 vehicles only.

- 1 *Cargo shell door strap* serves as a grab strap to lower cargo shell door.
- 2 *Cargo shell door assist cylinders* provide a lift boost for raising and holding cargo shell door open.
- 3 *Cargo shell door* when door rear latch is released, door opens forward and permits access to cargo area from rear of vehicle for stowing.
- 4 *Cargo shell door rear latch* is pulled upward to open cargo shell door from rear of vehicle.
- 5 *Cargo shell door retaining cables* limit cargo shell door travel when opened from either end.
- 6 *Cargo C-pillar door handle and locking mechanism* serves to open or close, lock or unlock the cargo C-pillar door.
- 7 *Cargo C-pillar door* provides access from the crew compartment to cargo shell.

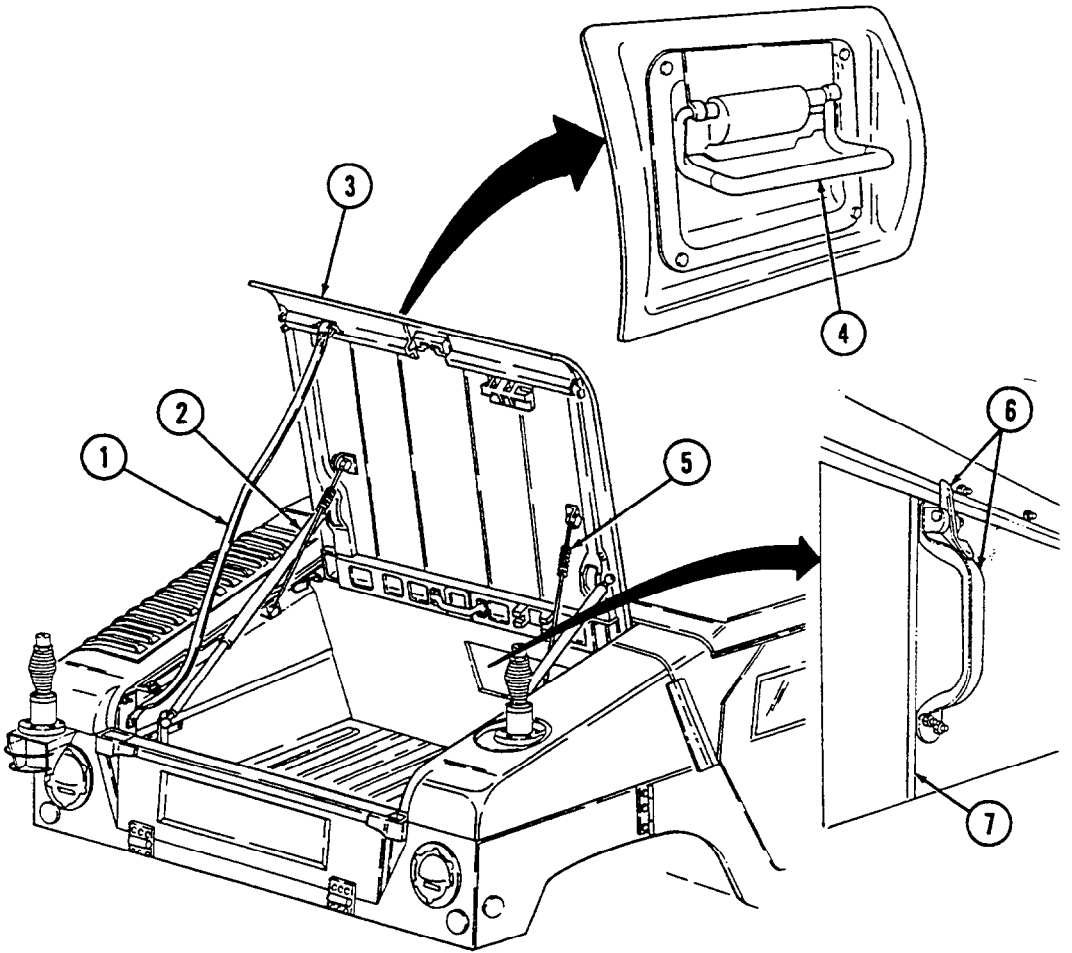

2-2. CONTROLS, INDICATORS, AND EQUIPMENT (Cont'd)

d. Up-Armored Carrier Equipment (M1114).

KEY ITEM AND FUNCTION

- 1 *Gunner's backrest* provides back support for a gunner positioned in weapon station.
- 2 *Weapon station hatch cover* provides sealed protective covering for roof opening when weapons are not mounted to weapon station.
- 3 *Hatch cover handle* is grab handle to assist gunner in opening and closing station cover.
- 4 *Rods* attached to cover serve to secure cover in the open position.
- 5 *Catch blocks* serve to support rods on weapon station while in the open position.
- 6 *Gunner's sling* serves as seat rest or restraint for a gunner positioned in weapon station.
- 7 *Hatch cover securing latches* (three each) secure cover to weapon station.
- 8 *Weapon station brake handle* locks the weapon station at the gunner's desired azimuth. Handle is placed in the down position for locking.
- 9 *Armament mount* is mounting bracket for weapon adapter.
- 10 *Universal weapons adapter pin assembly* secures weapon adapter to the armament mount.
- 11 *Universal weapons adapter* provides mounting base for the M60 7.62 mm machine gun, M2 caliber .50 machine gun, and MK19 grenade launcher.
- 12 *Weapon station* serves as rotating mounting platform for weapon components; can be continuously rotated 360°.

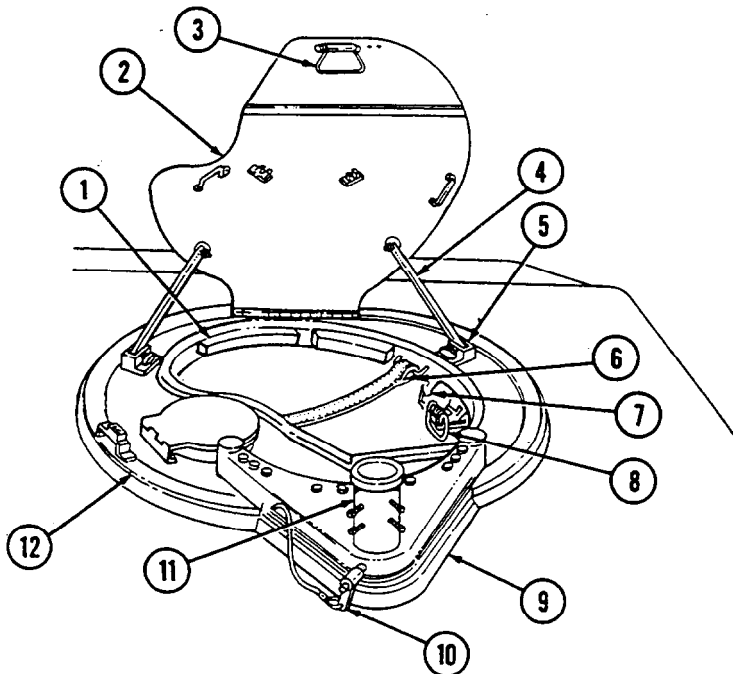

KEY ITEM AND FUNCTION

- 13 *Traversing Unit (TU) mount adapter* adapts TU to the TU stowage pedestal or weapon station pedestal mount.
- 14 *Traversing unit stowage pedestal* provides mounting base for TU mount adapter.
- 15 *Lower traversing unit mount adapter clamp* secures TU mount adapter to the stowage pedestal or weapon station pedestal mount.
- 16 *Upper traversing unit mount adapter clamp* secures TU to TU mount adapter.
- 17 *Camouflage screen stowage straps* (four each) secure camouflage screen and support to tailgate.

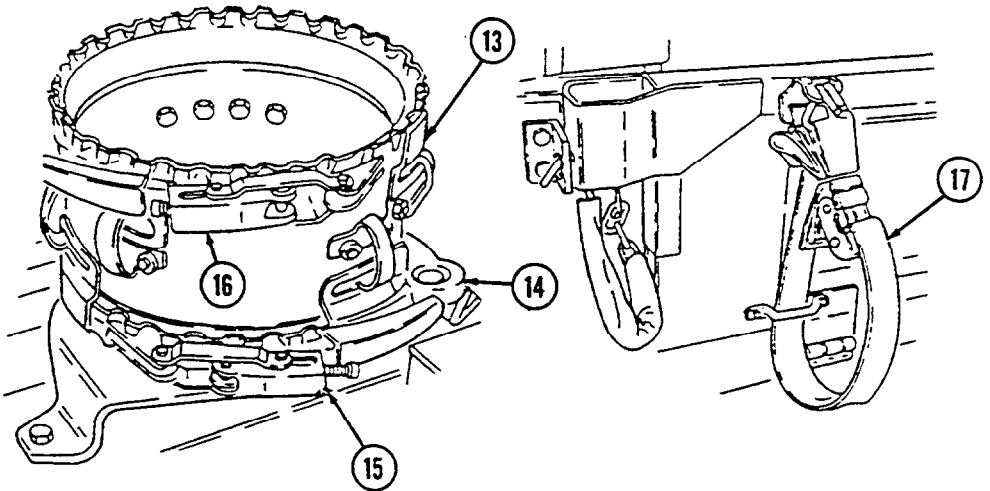

2-2. CONTROLS, INDICATORS, AND EQUIPMENT (Cont'd)

KEY ITEM AND FUNCTION

- 1 *Rear seat stowage compartment net* secures extra gear and ammo in crew compartment.
- 2 *Hatch stowate net* secures three duffel bags to vehicle hatch.

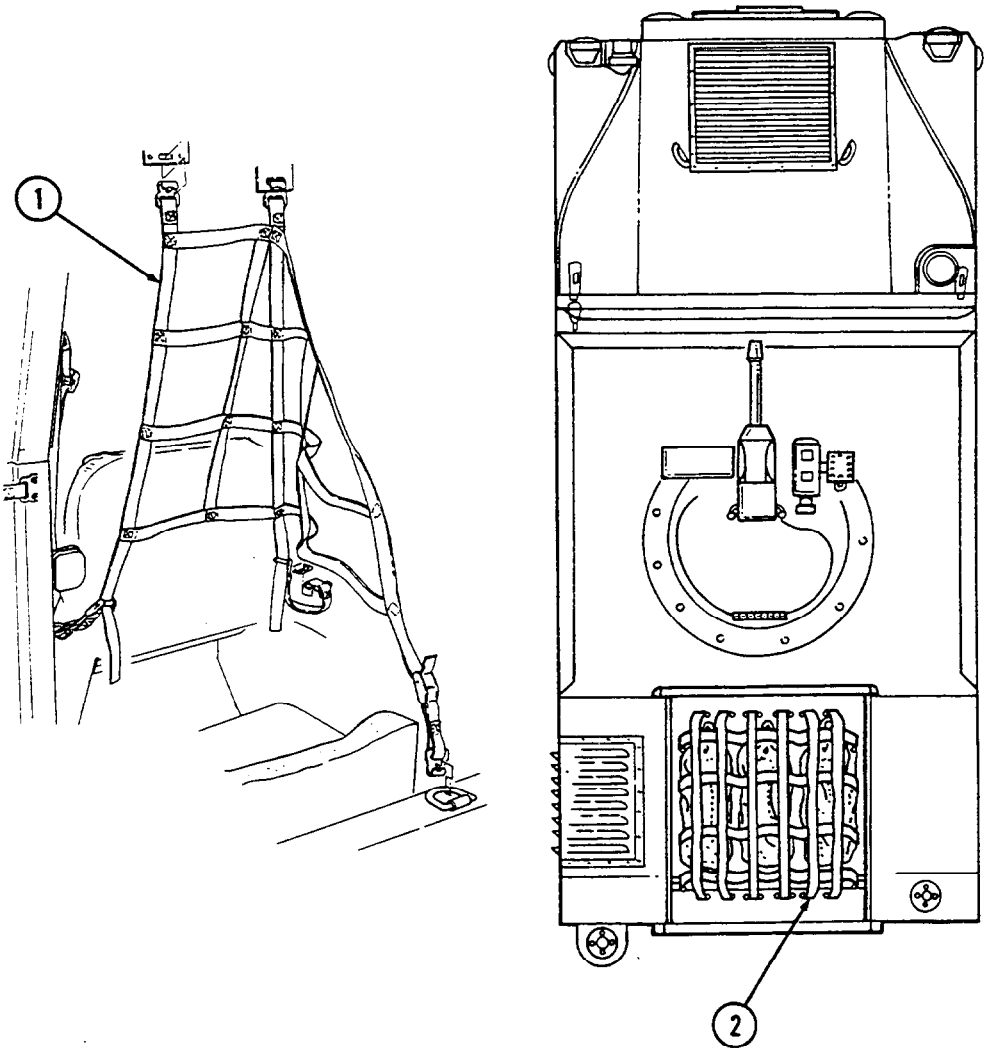

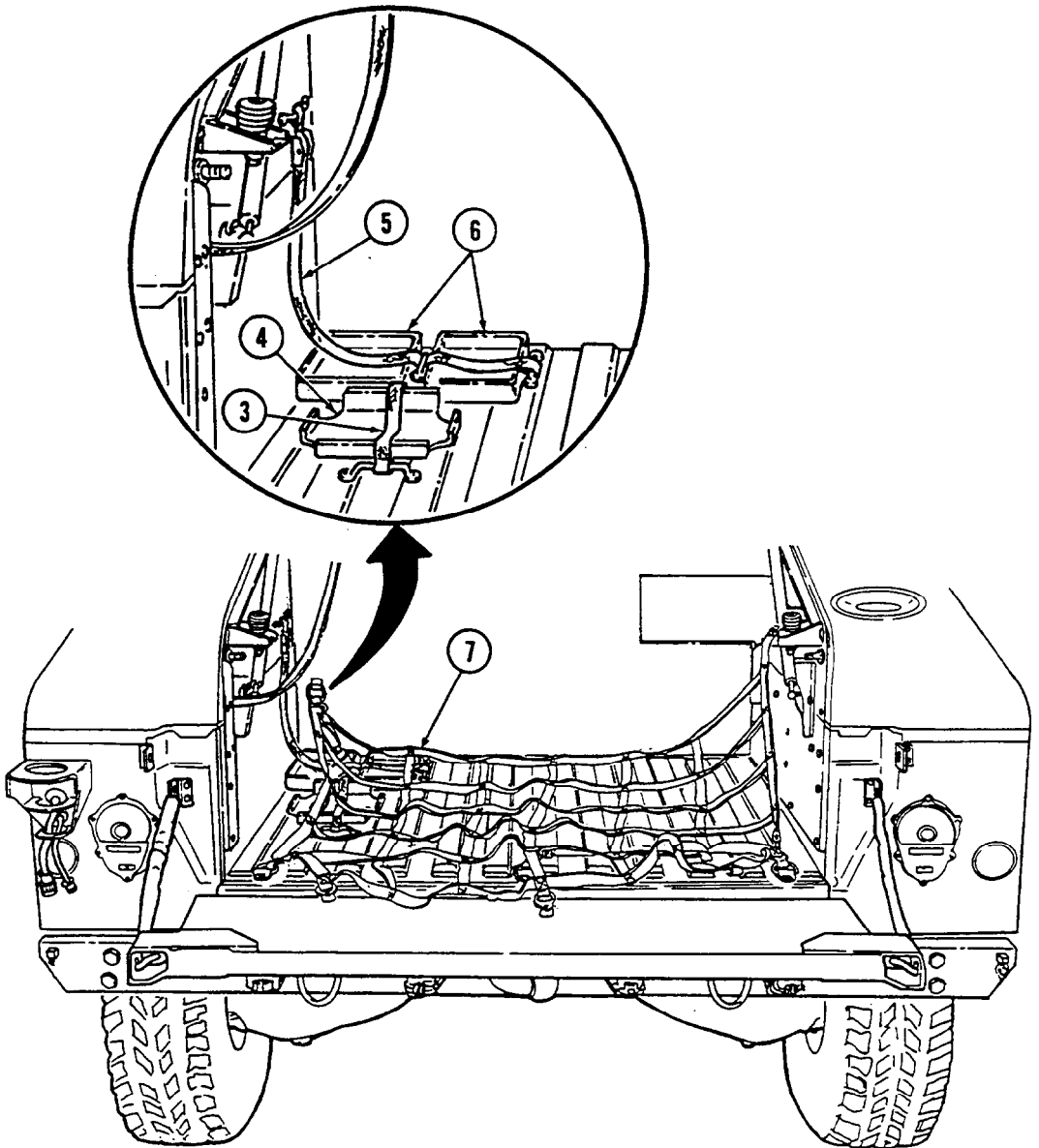

KEY ITEM AND FUNCTION

- 3 *Water can footman loop and strap secure water can to bracket.*
- 4 *Water can bracket provides stowage base for five-gallon water can.*
- 5 *Fuel can footman loops and straps secure two fuel cans to fuel can stowage brackets.*
- 6 *Fuel can stowage brackets permit stowage of two fuel cans.*
- 7 *Stowage compartment net secures items stowed in vehicle cargo area.*

2-2. CONTROLS, INDICATORS, AND EQUIPMENT (Cont'd)

KEY ITEM AND FUNCTION

- 1 *Gunner's platform* provides a non-slip platform for gunner.
- 2 *Ammo box racks* provides stowage base for three 40 mm ammo boxes.
- 3 *Ammo box footman loops and straps* (two each) secure three 40 mm ammo boxes to ammo box rack.
- 4 *Ammo box racks* serve as stowage base for two caliber .50 ammo boxes.
- 5 *Ammo box footman loops and straps* (two each) secure caliber .50 ammo boxes.

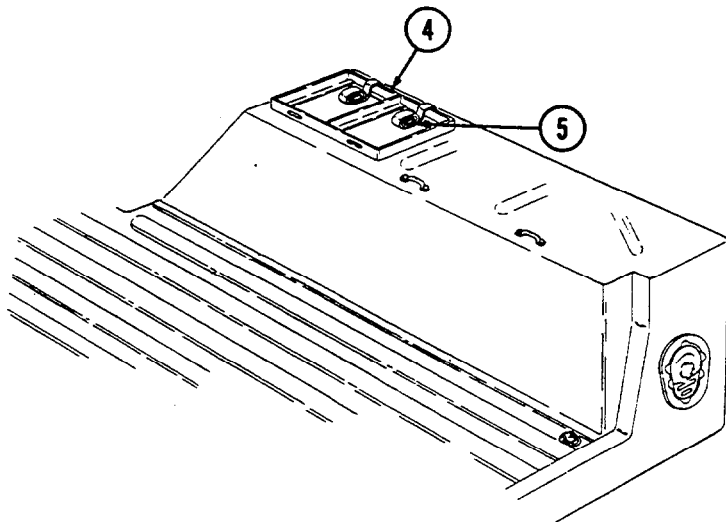
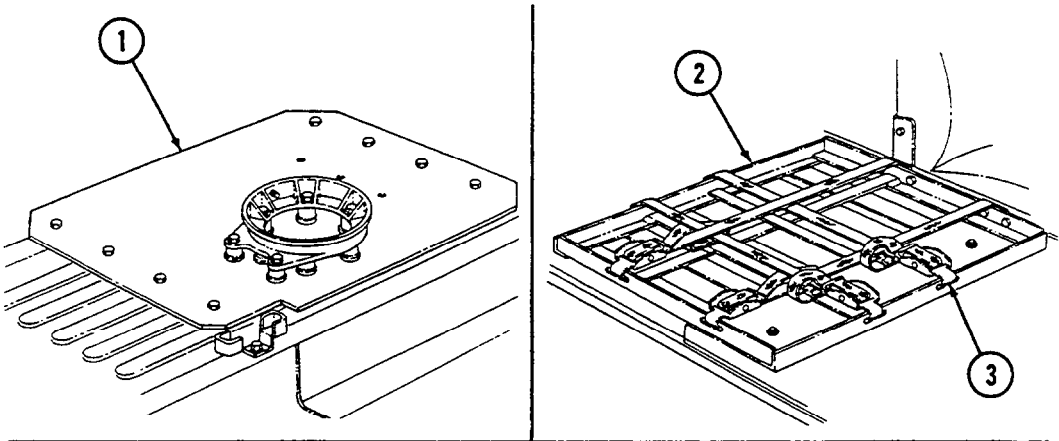

e. S250 Shelter Carrier Equipment (M1113).

KEY ITEM AND FUNCTION

CAUTION

The M1113 shelter carriers are specifically designed to be operated with the S250 shelter installed. Driving for long distances without the shelter installed, or equivalent payload of 1,500 lb (681 kg) evenly distributed in center of cargo area, will cause damage to equipment. However they can be driven safely without the shelter or an equivalent payload of 1,500 lb (681 kg) for short distances (e.g., to and from maintenance, or from the railhead when being delivered).

- 1 *Shelter reinforcement brackets* (four each) secure S250 shelter carrier to vehicle body.
- 2 *Rear suspension tiedown kit* is used to compress rear suspension to obtain an overall vehicle height of 102 in. (259 cm).

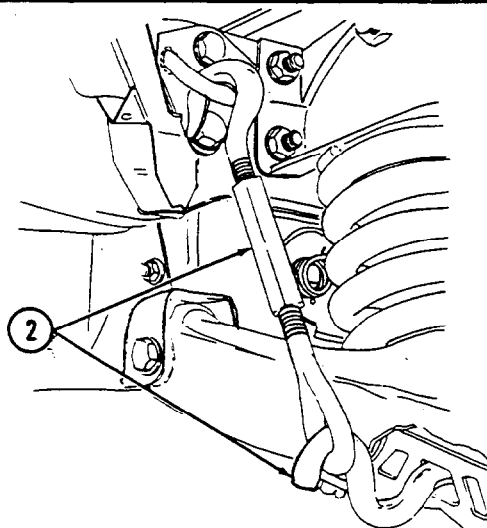
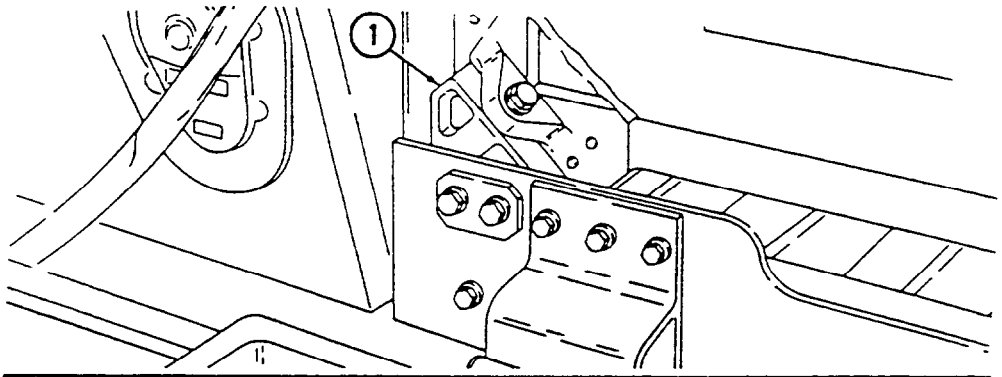

Section II. PREVENTIVE MAINTENANCE CHECKS AND SERVICES (PMCS)

2-3. GENERAL

A permanent record of the services, repairs, and modifications made to these vehicles must be recorded. See DA Pam 738-750 for a list of the forms and records required and how to complete them.

2-4. PREVENTIVE MAINTENANCE CHECKS AND SERVICES REFERENCE INDEX

REF. PARA.	TITLE	PAGE NO.
2-5.	Cleaning Instructions	2-26
2-6.	Preventive Maintenance Checks and Services (PMCS)	2-27
2-7.	Fluid Leakage	2-28
2-8.	Lubrication Requirements	2-28

2-5. CLEANING INSTRUCTIONS

a. Cleaning. An after operation service performed by the operator/crew to keep the vehicle in a state of readiness. Facilities and material available to operators for vehicle cleaning can vary greatly in differing operating conditions. However, vehicles must be maintained in as clean a condition as available cleaning equipment, materials, and tactical situations permit.

WARNING

- Drycleaning solvent is flammable and will not be used near an open flame. A fire extinguisher will be kept nearby when the solvent is used. Use only in well-ventilated places. Failure to do this may result in injury to personnel and/or damage to equipment.
- Protective gloves, clothing, and/or respiratory equipment must be worn whenever caustic, toxic, or flammable cleaning solutions are used. Failure to do this may result in injury to personnel and/or damage to equipment.

CAUTION

- Do not allow cleaning compounds to come into contact with rubber, leather, vinyl, or canvas materials. Damage to equipment will result.
- Do not use compressed air when cleaning vehicle interiors. Damage to equipment will result.
- Do not allow water to enter air cleaner assembly air intake weathercap. Damage to engine will occur.

b. Cleaning Instructions for Ballistic Glass.**CAUTION**

- Do not clean interior surfaces of ballistic glass by any other means than specified below.
- Do not use a scraper or other objects with sharp edges that may scratch the inside surfaces of ballistic glass.
- Do not apply stickers, labels, solvents, abrasive materials, or cleaners to ballistic glass.

(1) Remove dust and loose abrasive particles using clean, filtered air at 20 psi (138 kPa) maximum.

(2) Wash with mild detergent and warm water. Dry using a clean, soft, lint-free cloth.

(3) Remove stubborn marks and stains using a clean, soft, lint-free cloth and equal parts of isopropyl alcohol or ethanol and water.

(4) Repeat step 2.

NOTE

Clean windshield wipers of debris on a regular basis to ensure proper vision.

c. Cleaning Materials. Detailed descriptions of specific cleaning compounds, cleaning solvents, drycleaning solutions, and corrosion-removing compounds are found in TM 9-247.

d. General Guidelines. Table 2-1 provides a general guide of cleaning materials used in removing contaminants from various parts of the vehicle.

2-5. CLEANING INSTRUCTIONS (Cont'd)

Table 2-1. General Cleaning Instructions.

Surface	Cleaning Materials Used to Remove		
	Oil/Grease	Salt/Mud/Dust/Debris	Surface Rust/Corrosion
Body	Detergent; water; rags.	Soapy water; soft brush; damp and dry rags.	Corrosion-removing compound; bristle brush; dry rags; lubricating oil.*
Vehicle Interior (Metals)	Detergent; damp and dry rags.	Damp and dry rags.	Corrosion-removing compound; bristle brush; dry rags; lubricating oil.*
Glass	Window cleaning compound; dry rags.	Window cleaning compound; dry rags.	Not applicable.
Ballistic Glass	Detergent; soapy water; dry rags.	Detergent; soapy water; dry rags.	Not applicable.
Plastic Windows	Soapy water; cream cleaner; dry rags.***	Soapy water; cream cleaner; dry rags.***	Not applicable.
Vehicle Interior (Seats and Straps)	Water; damp and dry rags.	Soapy water; damp and dry rags.	Not applicable.
Frame	Detergent rinsed with water; dry rags.	Soapy water; damp and dry rags.	Corrosion-removing compound; wire brush; dry rags; lubricating oil.*
Engine and Transmission	Drycleaning solvent; water; rags.	Soapy water; soft wire brush; damp and dry rags.	Bristle brush; warm water; dry rags.
Radiator	Not applicable.	Low pressure water or air; soapy water; damp and dry rags.	Not applicable.
Oil Cooler	Not applicable.	Low pressure water or air; soapy water; damp and dry rags.**	Not applicable.
Master Cylinder	Detergent; rinsed with soapy water; dry rags.	Soapy water; damp and dry rags.	Not applicable.
Rubber Insulation	Damp and dry rags.	Damp and dry rags.	Not applicable.
Tires	Soapy water; damp rags.	Soapy water; damp rags.	Not applicable.
Wood	Detergent; water; damp and dry rags.	Low pressure water; soapy water; damp and dry rags.	Not applicable.

* After cleaning, apply light grade of lubricating oil to all unprotected surfaces to prevent continued rust.

** If more space is needed to clean mud and debris between the oil cooler and radiator, refer to unit maintenance.

*** After cleaning window zippers, apply zipper lubricant (appendix D, item 19). Operator may perform this cleaning procedure under the supervision of unit level maintenance.

2-6. PREVENTIVE MAINTENANCE CHECKS AND SERVICES (PMCS)

a. Designated Intervals.

NOTE

Designated intervals are performed under usual operating conditions. PMCS intervals must be performed more frequently when operating under unusual conditions.

- (1) BEFORE checks and services of PREVENTIVE MAINTENANCE must be performed prior to placing vehicle or its components in operation.
- (2) DURING checks and services of PREVENTIVE MAINTENANCE must be performed while the vehicle and/or its components/systems are in operation.
- (3) AFTER checks and services of PREVENTIVE MAINTENANCE are performed upon completion of mission.
- (4) WEEKLY checks and services of PREVENTIVE MAINTENANCE are performed once every 7 days.
- (5) MONTHLY checks and services of PREVENTIVE MAINTENANCE are performed once every 30 days.

b. Procedures.

- (1) For troubleshooting malfunctions, refer to table 3-1 or notify your supervisor.
- (2) Use DA Form 2404 and report malfunctions to unit maintenance at once.
- (3) Tools included with vehicle are to be used when making PREVENTIVE MAINTENANCE checks and services. Wiping cloths are needed to remove dirt or grease.
- (4) Refer to appropriate TMs for PMCS requirements on mounted systems (i.e., missiles systems, radios, etc.).

c. Troublespots.

NOTE

Dirt, grease, oil, and debris may cover up a serious problem. Clean as you check. Following precautions printed on container, use drycleaning solvent (P-D-680) on all metal surfaces. On rubber or plastic material, use soap and water.

- (1) Check all bolts, nuts, and screws. If loose, bent, broken, or missing, either tighten or report conditions to unit maintenance.
- (2) Look for loose or chipped paint, and rust or cracks at welds. Remove rust and loose paint, and spot-paint as required. If a cracked weld is found, report situation to unit maintenance.
- (3) Inspect electrical wires and connectors for cracked or broken insulation. Also look for bare wires and loose or broken connections. Tighten loose connections. Report other problems to unit maintenance.
- (4) Check hoses and fluid lines for wear, damage, and leaks. Ensure clamps and fittings are tight. (Refer to para. 2-7 for information on leaks.)
- (5) Check hinges for security and operation.
- (6) Check data, caution, and warning plates for security and legibility.

2-6. PREVENTIVE MAINTENANCE CHECKS AND SERVICES (PMCS) (Cont'd)

- d. **Not Ready/Available.** If a vehicle is not able to perform the mission, equipment will be reported as not ready/available. Refer to DA Pam 738-750.
- e. **Correct Assembly or Stowage.** Check each component for installation as an assembly, that it is in the right place, and has no missing parts.

2-7. FLUID LEAKAGE

Wetness around seals, gaskets, fittings, or connections indicates leakage. A stain also denotes leakage. If a fitting or connector is loose, tighten it. If broken or defective, report it. Use the following as a guide:

- a. **Class I.** Leakage indicated by wetness or discoloration, but not great enough to form drops.
- b. **Class II.** Leakage great enough to form drops, but not enough to cause drops to drip from item being checked/inspected.
- c. **Class III.** Leakage great enough to form drops that fall from the item being checked/inspected.

CAUTION

Operation is allowable with class I or II leakage except for brake system. Any brake fluid leakage must be reported. **WHEN IN DOUBT, NOTIFY YOUR SUPERVISOR.** When operating with class I or II leaks, check fluid levels more frequently. Class III leaks must be reported immediately to your supervisor or to unit maintenance. Failure to do this may result in damage to vehicle and/or components.

2-8. LUBRICATION REQUIREMENTS

For lubrication requirements and procedures, refer to appendix G.

Table 2-2. Preventive Maintenance Checks and Services.

Item No.	Interval	Location	Crewmember Procedure	Not Fully Mission Capable If:
		Item to Check/Service		
1	Before	Left Front, Side Exterior	<p style="text-align: center;"><u>WARNING</u></p> <p>Always remember the WARNINGS, CAUTIONS, and NOTES before operating this vehicle and prior to PMCS.</p> <p style="text-align: center;"><u>NOTE</u></p> <p>Perform your before, after, and weekly checks if:</p> <ul style="list-style-type: none"> a. You are the assigned driver but have not operated the vehicle since the last weekly inspection. b. You are operating the vehicle for the first time. <p><u>DRIVER</u></p> <p style="text-align: center;"><u>CAUTION</u></p> <p>If leaks are detected in the area of the transfer case oil cooler, do not attempt to tighten retaining nuts; internal damage to the transfer case oil cooler may result. Notify unit maintenance.</p> <p style="text-align: center;"><u>NOTE</u></p> <p>If leakage is detected, further investigation is needed to determine the location and cause of the leak.</p> <ul style="list-style-type: none"> a. Visually check underneath vehicle for any evidence of fluid leakage. 	<ul style="list-style-type: none"> a. Any brake fluid leaks; class III leak of oil, fuel, or coolant.

Table 2-2. Preventive Maintenance Checks and Services (Cont'd).

Item No.	Interval	Location	Crewmember Procedure	Not Fully Mission Capable If:
		Item to Check/Service		
1	Before	Left Front, Side Exterior (Cont'd)	<p>b. Visually check front and left side of vehicle for obvious damage that would impair operation.</p> <p><u>DRIVER</u></p>	b. Any damage prevents operation.
2	Before	Left Side Tires	<p><u>WARNING</u></p> <p>Operating a vehicle with a tire in an underinflated condition or with a questionable defect may lead to premature tire failure and may cause equipment damage and injury or death to personnel.</p> <p>Visually check tires for under-inflation and defects.</p> <p><u>DRIVER</u></p>	Tire missing, deflated, or unserviceable.
3	Before	Rear Exterior	<p>NOTE</p> <p>If leakage is detected, further investigation is needed to determine the location and cause of the leak.</p> <p>a. Visually check underneath vehicle for evidence of fluid leakage.</p> <p>b. Visually check rear of vehicle for obvious damage that would impair operation.</p>	<p>a. Any brake fluid leaks; class III leak of oil, fuel, or coolant.</p> <p>b. Any damage prevents operation.</p>

Table 2-2. Preventive Maintenance Checks and Services (Cont'd).

Item No.	Interval	Location	Crewmember Procedure	Not Fully Mission Capable If:
		Item to Check/Service		
4	Before	Right Front, Side Exterior	<p><u>DRIVER</u></p> <p>NOTE If leakage is detected, further investigation is needed to determine the location and cause of the leak.</p> <p>a. Visually check underneath vehicle for evidence of fluid leakage.</p> <p>b. Visually check front and right side of vehicle for obvious damage that would impair operation.</p>	<p>a. Any brake fluid leaks; class III leak of oil, fuel, or coolant.</p> <p>b. Any damage prevents operation.</p>
5	Before	Right Side Tires	<p><u>DRIVER</u></p> <p><u>WARNING</u></p> <p>Operating a vehicle with a tire in an underinflated condition or with a questionable defect may lead to premature tire failure and may cause equipment damage and injury or death to personnel.</p> <p>Visually check tires for underinflation and defects.</p>	<p>Tire missing, deflated, or unserviceable.</p>

Table 2-2. Preventive Maintenance Checks and Services (Cont'd).

Item No.	Interval	Location	Crewmember Procedure	Not Fully Mission Capable If:
		Item to Check/Service		
6	Before	Front	<p><u>DRIVER</u></p> <p>NOTE</p> <p>If leakage is detected, investigation is needed to determine the location and cause of the leak.</p> <p>a. Visually check front of vehicle for obvious damage that would impair operation.</p> <p>b. Visually check underneath vehicle for evidence of fluid leakage.</p>	<p>a. Any damage prevents operation.</p> <p>b. Any brake leaks; class III leak of oil, fuel, or coolant.</p>
7	Before	Cooling System	<p><u>DRIVER</u></p> <p><u>WARNING</u></p> <p>If engine has been recently operated, do not remove radiator cap to check coolant level. Cooling system is under pressure, and escaping steam or coolant can cause burns.</p> <p><u>CAUTION</u></p> <p>Overheating due to lack of coolant will cause engine damage.</p> <p>Check coolant level in coolant tank. Level should be at or above the FULL COLD line. Add coolant if below the FULL line.</p>	

Table 2-2. Preventive Maintenance Checks and Services (Cont'd).

Item No.	Interval	Location	Crewmember Procedure	Not Fully Mission Capable If:
		Item to Check/Service		
8	Before	Power Steering Reservoir	<p><u>DRIVER</u></p> <p>CAUTION</p> <ul style="list-style-type: none"> • Do not permit dirt, dust, or grit to enter power steering reservoir. Damage to power steering system will result if power steering fluid becomes contaminated. • Do not overfill power steering reservoir. Damage to power steering system will result.  <p>Check fluid in power steering reservoir. Fluid should be between HOT and COLD marks. Add fluid if level is below COLD mark.</p>	

Table 2-2. Preventive Maintenance Checks and Services (Cont'd).

Item No.	Interval	Location	Crewmember Procedure	Not Fully Mission Capable If:
		Item to Check/Service		
9	Before	Seat and Seatbelts	<p><u>DRIVER</u></p> <p>NOTE</p> <p>Vehicle operation with inoperative seatbelts may violate AR 385-55.</p> <p>a. Check all seatbelts for security, damage, and operation of buckle and clasp ends.</p> <p>b. Check operation of seat adjusting mechanism (driver's seat only).</p>	<p>b. Seat adjustment lock broken or missing.</p>
10	Before	Fire Extinguisher	<p><u>DRIVER</u></p> <p>a. Check for missing or damaged fire extinguisher.</p> <p>b. Check gauge for proper pressure of about 150 psi (1,034 kPa).</p> <p>c. Check for damaged or missing seal.</p>	<p>a. Fire extinguisher missing or damaged.</p> <p>b. Pressure gauge needle in recharge area.</p> <p>c. Seal broken or missing.</p>

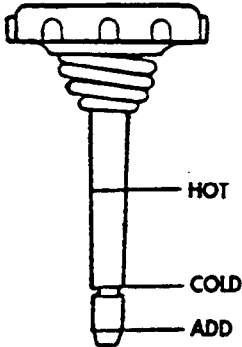
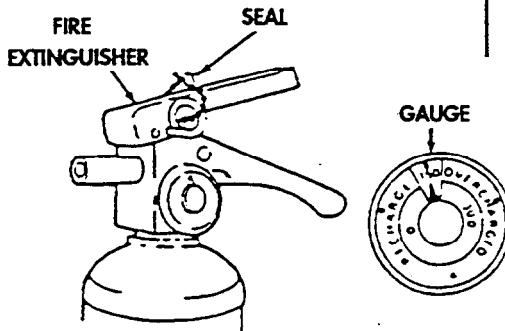

Table 2-2. Preventive Maintenance Checks and Services (Cont'd).

Item No.	Interval	Location	<u>Crewmember Procedure</u>	Not Fully Mission Capable If:
		Item to Check/Service		
11	Before	Gear Shifter Lever	<p><u>DRIVER</u></p> <p>a. Check transmission shift lever operation. Shift transmission lever through all operating ranges. Lever should move freely through all range positions.</p> <p>b. Check transfer shift lever operation. With transmission in N, shift transfer lever through all range positions. Lever should move freely through all range positions.</p>	<p>a. Lever inoperable or binds between range detents.</p> <p>b. Lever inoperable or binds between range detents.</p>
12	Before	Instrument Panel	<p><u>DRIVER</u></p> <p><u>WARNING</u></p> <p>If gauges, instruments, or instrument lights are inoperable or not within ranges described in these checks, immediately shut off engine and notify your supervisor or unit maintenance personnel. Continued operation of vehicle may result in injury to personnel or damage to equipment.</p>	

Table 2-2. Preventive Maintenance Checks and Services (Cont'd).

Item No.	Interval	Location	Crewmember Procedure	Not Fully Mission Capable If:
		Item to Check/Service		
12	Before	Instrument Panel (Cont'd)	<p>NOTE</p> <p>If engine is warm, wait-to-start light may not come on. During cranking or after starting, light may go on and off a few times.</p> <p>a. Check wait-to-start light and brake warning light. Turn rotary switch to RUN. Wait-to-start and brake warning light should come on.</p>	<p>a. Wait-to-start light does not come on when engine is cold, or wait light stays on continually. Brake warning light does not come on.</p>
 <p>The diagram shows a section of the instrument panel. On the left, there is a 'WAIT-TO-START LAMP' and a 'ROTARY SWITCH'. To the right of the rotary switch is a 'BRAKE WARNING LAMP'. The rotary switch is a circular dial with a pointer. The lamps are small circular indicators. The diagram is a line drawing showing the relative positions of these components on the instrument panel.</p>				

Table 2-2. Preventive Maintenance Checks and Services (Cont'd).

Item No.	Interval	Location	Crewmember Procedure	Not Fully Mission Capable If:
		Item to Check/Service		
12	Before	Instrument Panel (Cont'd)	<p>b. Start engine and check the following:</p> <p>c. Engine oil pressure gauge.</p> <p>d. Voltmeter.</p> <p>e. Air restriction gauge.</p> <p>f. Brake warning light should go off when hand brake is released.</p> <p>g. Check fuel gauge.</p> <p>h. Check coolant temperature gauge.</p>	<p>b. Engine will not start.</p> <p>c. Oil pressure is less than 6 psi (41 kPa) at idle or 15 psi (103 kPa) under load.</p> <p>d. Voltmeter needle stays in yellow or red range.</p> <p>e. Air restriction indicator reaches red zone.</p> <p>f. Brake warning light stays on after hand brake is released or comes on while driving.</p> <p>h. Coolant temperature gauge reads greater than 230°F (110°C).</p>

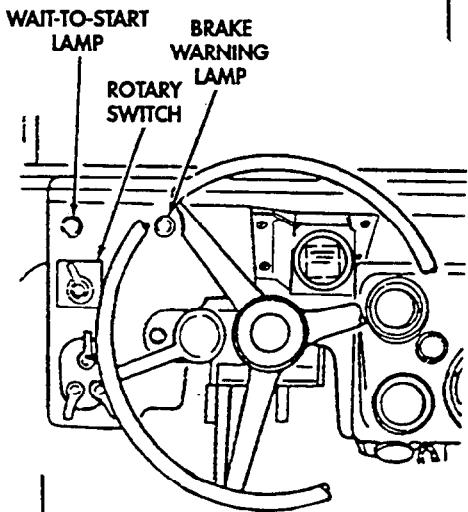
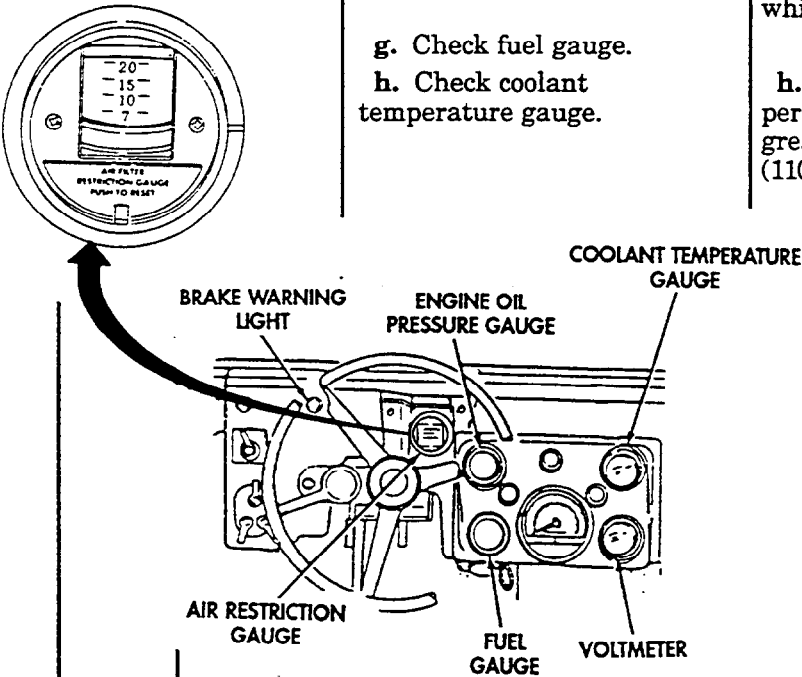

The diagram shows a top-down view of the instrument panel. A callout circle on the left shows a close-up of the 'AIR FILTER RESTRICTION GAUGE' with a scale from 0 to 20 and a 'PUSH TO RESET' button. Labels with arrows point to the 'BRAKE WARNING LIGHT', 'ENGINE OIL PRESSURE GAUGE', 'AIR RESTRICTION GAUGE', 'FUEL GAUGE', 'VOLTMETER', and 'COOLANT TEMPERATURE GAUGE' on the main panel.

Table 2-2. Preventive Maintenance Checks and Services (Cont'd).

Item No.	Interval	Location	Crewmember Procedure	Not Fully Mission Capable If:
		Item to Check/Service		
13	Before	Steering	<p><u>DRIVER</u></p> <p>Check steering wheel for operation. With engine running, turn steering wheel from left to right. Steering wheel should move freely.</p>	Steering wheel inoperable or binds.
14	Before	Brakes	<p><u>DRIVER</u></p> <p>NOTE</p> <p>Engine must be warmed up and idling, transmission in D (overdrive), transfer in H (high), and parking brake released to perform the following check.</p> <p>a. Check brake pedal travel. With vehicle at idle, transfer in H, and transmission in D, allow vehicle to move forward. As vehicle moves, slowly depress brake pedal. Pedal should travel 1 to 1-1/2 in. (2.5 to 3.8 cm) before brakes take hold. After brakes take hold, pedal may exceed the 1 to 1-1/2 in. (2.5 to 3.8 cm) travel. This is normal.</p> <p>b. Check parking brake. With parking brake fully applied, transmission in D or R, and transfer in H, vehicle should not move.</p> <p>c. Check parking brake lever safety mechanism to ensure that it latches when parking brake is applied.</p>	<p>a. Brakes will not stop the vehicle.</p> <p>b. Parking brake inoperable or unable to hold vehicle.</p> <p>c. Parking brake lever safety mechanism is not functioning properly.</p>

Table 2-2. Preventive Maintenance Checks and Services (Cont'd).

Item No.	Interval	Location	Crewmember Procedure	Not Fully Mission Capable If:
		Item to Check/Service		
15	Before	Weapon Station	<p><u>DRIVER</u></p> <p>NOTE Weapon station binding should be checked with weapon system or equivalent weight applied to turret. Refer to appropriate system TM to determine weight of weapon system.</p> <p>a. Check weapon station for binding by rotating 360° in both directions at least five times.</p> <p>b. Check armament mounting plate and bearing sleeve for security of mounting and obvious damage that would impair operation.</p>	<p>a. Weapon station binds.</p> <p>b. Armament weapons required for missions and mounting plate or bearing sleeve missing, or any damage that will prevent or impair mounting of armament weapons.</p>
16	During	Controls and Indicators	<p><u>DRIVER</u></p> <p>a. Monitor all gauges and speedometer.</p> <p>b. Monitor engine oil pressure gauge.</p>	<p>a. Gauges drop below normal reading.</p> <p>b. Engine oil pressure gauge reads less than approximately 40 psi (276 kPa) under normal driving conditions or less than 6 psi (41 kPa) at idle.</p>

Table 2-2. Preventive Maintenance Checks and Services (Cont'd).

Item No.	Interval	Location	Crewmember Procedure	Not Fully Mission Capable If:
		Item to Check/Service		
17	During	Brakes	<u>DRIVER</u> Check brakes for pulling or grabbing.	Brakes pull or grab.
18	During	Steering	<u>DRIVER</u> Be alert for excessive sway, leaning to one side, or unstable handling. Check steering response for unusual free play, binding, or shimmy.	Handling is unstable; turning is difficult or nonexistent.
19	During	Power-train	<u>DRIVER</u> Be alert for unusual noises or vibrations from engine, transmission, transfer, differentials, propeller shafts, axle shafts, or wheels.	Unusual noise or vibration detected.
20	During	Transmission	<u>DRIVER</u> Check transmission for proper operation.	Transmission slips or will not shift.
21	During	Air Conditioner	<u>DRIVER</u> NOTE Perform the following inspection only if the air conditioner is required for climatic conditions. Turn air conditioner on (para. 2-35) and wait 5 minutes to allow temperature to stabilize. Check vents for cool air. If air is not cooler than ambient temperature, notify your supervisor and record on DA Form 2404.	

Table 2-2. Preventive Maintenance Checks and Services (Cont'd).

Item No.	Interval	Location	Crewmember Procedure	Not Fully Mission Capable If:
		Item to Check/Service		
22	After 	Transmission Fluid	<p><u>DRIVER</u></p> <p>CAUTION</p> <ul style="list-style-type: none"> • Do not permit dirt, dust, or grit to enter transmission oil dipstick tube. Internal transmission damage will result if transmission oil becomes contaminated. • Do not overfill transmission. Damage to transmission will result. An over-full transmission can also indicate a transfer case fluid leak. Notify unit maintenance if transmission fluid is above crosshatch mark. <p>NOTE</p> <p>Transmission fluid level should be checked with engine running, parking brake set, transmission shift lever in N, and vehicle on level ground. Fluid level should be at cross-hatch marks on dipstick.</p>	

Table 2-2. Preventive Maintenance Checks and Services (Cont'd).

Item No.	Interval	Location	Crewmember Procedure	Not Fully Mission Capable If:
		Item to Check/Service		
22	After	Transmission Fluid (Cont'd)	<p>NOTE</p> <p>Engine operating temperature of 190-230°F (88-110°C) must be reached before performing AFTER checks.</p> <p>Check transmission fluid level. If level is below the crosshatch marks, add sufficient fluid to bring the level to the crosshatch marks.</p>	
23	After	Fuel Filter	<p><u>DRIVER</u></p> <p>WARNING</p> <p>Do not perform fuel system checks, inspections, or maintenance while smoking or near fire, flames, or sparks. Fuel may ignite, causing damage to vehicle and injury or death to personnel.</p> <p>NOTE</p> <p>A rubber hose can be attached to drainvalve to catch fuel in container before opening drainvalve.</p> <p>a. Check fuel for contamination. With engine running, open drainvalve. Allow fuel to drain into suitable container until it runs clear. Close valve.</p>	<p>a. Fuel is not clear after draining 1 pt (0.47 L).</p>

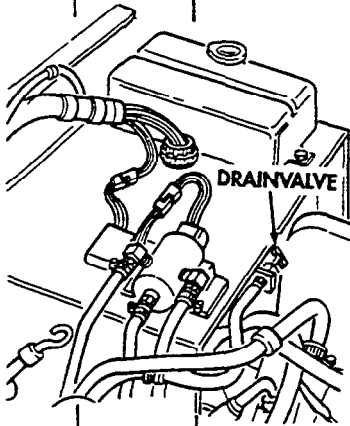

Table 2-2. Preventive Maintenance Checks and Services (Cont'd).

Item No.	Interval	Location	<u>Crewmember Procedure</u>	Not Fully Mission Capable If:
		Item to Check/Service		
23	After	Fuel Filter (Cont'd)	<p>NOTE</p> <p>Fuel retained in the drainvalve may drip when vehicle vibrations occur. This is normal and does not constitute a leak. Wipe drainvalve with rag until excess fuel is removed.</p> <p>b. Check for leaks.</p> <p>c. Stop engine and remove rubber hose from drainvalve, if installed.</p>	b. Class III leakage evident.
24	After	Left Side Tires	<p><u>DRIVER</u></p> <p>WARNING</p> <p>Operating a vehicle with a tire in an underinflated condition or with questionable defect may lead to premature tire failure and may cause equipment damage and injury or death to personnel.</p> <p>Visually check tires for underinflation, cuts, gouges, cracks, or bulges. Remove all penetrating objects.</p>	Tire deflated or otherwise unserviceable.
25	After	Mirror (Left Side)	<p><u>DRIVER</u></p> <p>NOTE</p> <p>Vehicle operation with damaged or missing outside rearview mirrors may violate AR 385-55.</p> <p>Check mirror for defects, cracks, and serviceability.</p>	

Table 2-2. Preventive Maintenance Checks and Services (Cont'd).

Item No.	Interval	Location	Crewmember Procedure	Not Fully Mission Capable If:
		Item to Check/Service		
26	After	Left Front, Side Exterior	<p><u>DRIVER</u></p> <p>NOTE If leakage is detected, further investigation is needed to determine the location and cause of the leak.</p> <p>a. Visually check underneath vehicle for evidence of fluid leakage.</p> <p>b. Visually check halfshaft cv boots and ball joint boots for rips, tears, or cuts.</p> <p>c. Inspect frame crossmembers and underbody support for missing hardware, cracks, breaks, and rust.</p> <p>d. Visually check for body damage that would impair operation of vehicle.</p>	<p>a. Any brake fluid leaks; class III leak of oil, fuel, or coolant.</p> <p>c. Crossmembers or underbody support are missing any hardware, or are cracked, broken, or rusted.</p> <p>d. Any damage will prevent operation.</p>
27	After	Rear Exterior	<p><u>DRIVER</u></p> <p>NOTE If leakage is detected, further investigation is needed to determine the location and cause of the leak.</p> <p>a. Visually check underneath vehicle for evidence of fluid leakage.</p>	<p>a. Any brake fluid leaks; class III leak of oil, fuel, or coolant.</p>

Table 2-2. Preventive Maintenance Checks and Services (Cont'd).

Item No.	Interval	Location	Crewmember Procedure	Not Fully Mission Capable If:
		Item to Check/Service		
27	After	Rear Exterior (Cont'd)	<p>b. Visually check halfshaft cv boots and ball joint boots for presence, rips, tears, or cuts.</p> <p>c. Inspect frame crossmembers and underbody support for missing hardware, cracks, breaks, and rust.</p> <p>d. Inspect bumper or crossmember and inner braces in area around towing pintle for cracks or breaks.</p> <p><u>DRIVER</u></p>	<p>c. Crossmembers or underbody support are missing any hardware or are cracked, broken, or rusted.</p> <p>d. Bumper, crossmember or an inner brace is cracked or broken.</p>
28	After	Right Side Tires	<p><u>WARNING</u></p> <p>Operating a vehicle with a tire in an underinflated condition or with questionable defect may lead to premature tire failure and may cause equipment damage and injury or death to personnel.</p> <p>Visually check tires for underinflation, cuts, gouges, cracks, or bulges. Remove all penetrating objects.</p> <p><u>DRIVER</u></p>	<p>Tire deflated or otherwise unserviceable.</p>
29	After	Mirror (Right Side)	<p><u>NOTE</u></p> <p>Vehicle operation with damaged or missing outside rearview mirrors may violate AR 385-55.</p> <p>Check mirror for defects, cracks, and serviceability.</p>	

Table 2-2. Preventive Maintenance Checks and Services (Cont'd).

Item No.	Interval	Location	Crewmember Procedure	Not Fully Mission Capable If:
		Item to Check/Service		
30	After	Right Front, Side Exterior	<p><u>DRIVER</u></p> <p>NOTE If leakage is detected, further investigation is needed to determine the location and cause of the leak.</p> <p>a. Visually check underneath vehicle for evidence of fluid leakage.</p> <p>b. Visually check halfshaft cv boots and ball joint boots for rips, tears, or cuts.</p> <p>c. Inspect frame crossmembers and underbody support for missing hardware, cracks, breaks, and rust.</p> <p>d. Visually check front and right side of vehicle for obvious damage that would impair operation.</p>	<p>a. Any brake fluid leaks; class III leak of oil, fuel, or coolant.</p> <p>c. Crossmembers or underbody support are missing any hardware or are cracked, broken, or rusted.</p> <p>d. Any damage will prevent operation.</p>
31	After	Engine Oil	<p><u>DRIVER</u></p> <p>CAUTION</p> <ul style="list-style-type: none"> • Do not permit dirt, dust, or grit to enter engine oil dipstick tube. Internal engine damage will result if engine oil becomes contaminated. • Do not overfill engine crankcase. Damage to engine will result. <p>Check engine oil level. Level should be between ADD and FULL. If level is below ADD, add oil to bring level between the ADD and FULL marks.</p>	Oil appears milky.

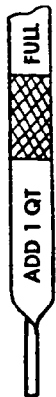

Table 2-2. Preventive Maintenance Checks and Services (Cont'd).

Item No.	Interval	Location	Crewmember Procedure	Not Fully Mission Capable If:
		Item to Check/Service		
32	After	Power Steering Lines and Fittings	<p><u>DRIVER</u></p> <p>CAUTION</p> <p>Notify unit maintenance if power steering system has class III leak. Loss of power assist could occur if this condition exists.</p> <p>Check power steering lines and fittings for leaks.</p>	Class III leakage evident.
33	After	Cooling System	<p><u>DRIVER</u></p> <p>Inspect radiator hoses for leakage.</p>	Class III leakage evident.
34	After	Master Cylinder	<p><u>DRIVER</u></p> <p>Visually check master cylinder lines for leaks and security of cover.</p>	Any leak, or cover missing.
35	After	Lights	<p><u>DRIVER</u></p> <p>CAUTION</p> <p>Never set the rotary switch to RUN to check the lights. This drains the batteries and can burn out the glow plugs and control box.</p> <p>NOTE</p> <p>Vehicle operation with damaged or inoperable headlights may violate AR 385-55.</p>	

Table 2-2. Preventive Maintenance Checks and Services (Cont'd).

Item No.	Interval	Location	<u>Crewmember</u> Procedure	Not Fully Mission Capable If:
		Item to Check/Service		
35	After	Lights (Cont'd)	<p>a. Check for presence and operation of service drive, turn signal, blackout marker, marker, blackout drive, and side marker lights.</p> <p>b. Check operation of tail/stop-lights. Push down brake pedal approximately 1/4 in. (6.4 mm). Tail/stoplights should come on.</p> <p><u>DRIVER</u></p>	
36	After	Horn	<p>NOTE</p> <p>Vehicle operation with inoperative horn may violate AR 385-55.</p> <p>Check operation of horn if tactical situation permits.</p> <p><u>DRIVER</u></p>	
37	After	Windshield and Wipers	<p>NOTE</p> <p>Vehicle operation with damaged windshield may violate AR 385-55.</p> <p>a. Check windshield for damage that would impair operator's vision.</p> <p>NOTE</p> <p>Vehicle operation with inoperative wipers may violate AR 385-55.</p> <p>b. Check windshield wiper and blade for defects and damage.</p>	a. Windshield is cracked sufficiently to impair operator's vision.

Table 2-2. Preventive Maintenance Checks and Services (Cont'd).

Item No.	Interval	Location	Crewmember Procedure	Not Fully Mission Capable If:
		Item to Check/Service		
38	After	Light Switches	<p><u>DRIVER</u></p> <p>NOTE</p> <p>Ensure all switches are in the OFF position. Failure to turn switches to the OFF position when not in use will drain the batteries.</p> <p>Check and ensure all switches are in the OFF position.</p>	

Table 2-2. Preventive Maintenance Checks and Services (Cont'd).

Item No.	Interval	Location	Crewmember Procedure	Not Fully Mission Capable If:
		Item to Check/Service		
39	Weekly	Tires	<p><u>DRIVER</u></p> <p><u>WARNING</u></p> <p>Do not exceed 50 psi (345 kPa) cold radial tire inflation pressure. Overinflation of tire may result in damage to equipment and injury or death to personnel.</p> <p>a. Check tire tread depth. Tread should not be worn beyond level of wear bar. Wear bars are molded across the tread pattern in the valley between the center rib and lugs. The Tread Wear Indicator letters (TWI) are molded on the sidewall to aid in locating the wear bar.</p> <p>NOTE</p> <p>The wear bars are not evident on new or very low mileage tires. The wear bars will appear after usual use.</p>	<p>a. Tread is worn even to height of tread wear indicator. Any cut, gouge, or crack extends to the cord body, or any bulges.</p>

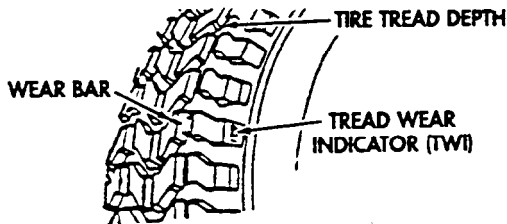

Table 2-2. Preventive Maintenance Checks and Services (Cont'd).

Item No.	Interval	Location	Crewmember Procedure	Not Fully Mission Capable If:
		Item to Check/Service		
39	Weekly	Tires (Cont'd)	<p>b. Measure tread thickness. Tread depth should not be less than 1/16 in. (1.59 mm) thick.</p> <p>c. Check for missing or loose wheel stud nuts and lug nuts. Tighten loose lug nuts and have unit maintenance tighten stud nuts and lug nuts to proper torque.</p>	<p>b. Tread depth less than 1/16 in. (1.59 mm).</p> <p>c. Any wheel stud nut or lug nut is broken or missing.</p>
				

Table 2-2. Preventive Maintenance Checks and Services (Cont'd).

Item No.	Interval	Location	Crewmember Procedure	Not Fully Mission Capable If:		
		Item to Check/ Service				
39	Weekly	Tires (Cont'd)	<p align="center"><u>WARNING</u></p> <p>Do not exceed 50 psi (345 kPa) cold radial tire inflation pressure. Over-inflation of tire may result in premature tire failure, damage to equipment, and injury or death to personnel.</p> <p>d. Gauge tires for correct air pressure using tire inflation gauge. Adjust as necessary.</p> <p align="center"><u>CAUTION</u></p> <p>The M1113 shelter carriers are specifically designed to be operated with the S250 shelter installed. They can be driven safely without the shelter installed, or with equivalent payload of 1,500 lb (681 kg), for short distances (e.g., to and from maintenance, or from the rail head when being delivered), but this should not be done often or for long distances. Driving for long distances without the shelter installed, or equivalent payload of 1,500 lb (681 kg) evenly distributed in center of cargo area, will cause damage to equipment.</p>			
VEHICLE			FRONT	REAR		
			Standard psi	Metric kPa	Standard psi	Metric kPa
UNLOADED*						
M1113			15	103	25	172
M1114			35	241	45	310
AT GVW (M1113)			30	207	40	276
AT GVW (M1114)			40	276	50	345
MUD, SAND, AND SNOW (30 mph [48 km] max. speed).			20	138	30	207
*Driver plus one passenger						

Table 2-2. Preventive Maintenance Checks and Services (Cont'd).

Item No.	Interval	Location	<u>Crewmember</u> Procedure	Not Fully Mission Capable If:
		Item to Check/Service		
40	Weekly	Exhaust System	<u>DRIVER</u> Check exhaust system for security of all mounts, tightness of clamps and bolts, rusted conditions, damaged pipes, and any indication of an exhaust leak.	Any mounts are broken, pipes are rusted through or broken, or any indication of an exhaust leak.
41	Weekly	Shock Absorbers	<u>DRIVER</u> Visually inspect shock absorbers for leaks, damage, and security of mounting.	Class III leakage or damage is evident; mounting damaged or loose.
42	Weekly	Doors and Windows	<u>DRIVER</u> Check operation of doors and windows.	
43	Weekly	Tailgate	<u>DRIVER</u> Check operation of tailgate. Check that tailgate latches securely and operates properly.	
44	Weekly	Body	<u>DRIVER</u> <ul style="list-style-type: none"> a. Inspect cargo shell door for bends, warping, binding, and ease of operation. Inspect latching mechanisms for proper operation. Inspect lift cylinders for bends and security of mounting. b. Inspect strap assembly for frays and security of mounting. 	<ul style="list-style-type: none"> a. Lift cylinders or latches bent, warped, binding, or inoperative.

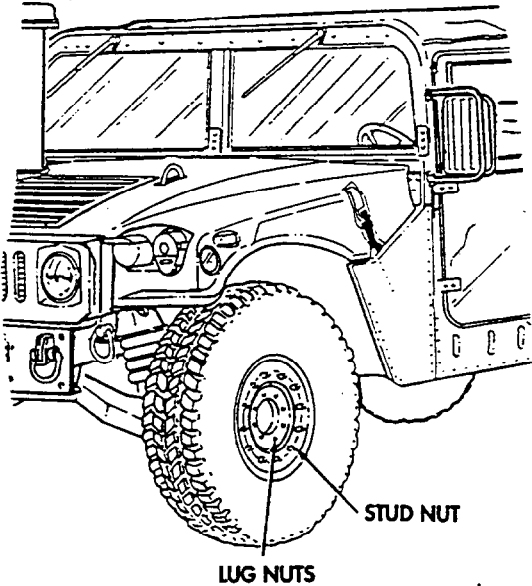
Table 2-2. Preventive Maintenance Checks and Services (Cont'd).

Item No.	Interval	Location	Crewmember Procedure	Not Fully Mission Capable If:
		Item to Check/Service		
44	Weekly	Body (Cont'd)	<p>c. Check cargo shell door for alignment as follows:</p> <p>(1) Insert a piece of paper between the door seal and door opening.</p> <p>(2) With door closed, seal should offer resistance to pulling out paper. If door seal does not offer resistance, adjustment is required.</p> <p>d. Check crew compartment armor for security of mounting.</p> <p>e. Check armor for loose or missing fasteners. Notify unit maintenance if any are found.</p>	
45	Weekly	Vehicular Heater	<p><u>DRIVER</u></p> <p>(Vehicle w/Vehicular Winterization Kit)</p> <p>a. Check heater and heater controls for proper operation.</p> <p>b. Check fuel lines and fittings for leaks, cracks, or breaks.</p> <p>c. Check electrical cables and connections for security, or frayed or broken wires.</p> <p>d. Check heater exhaust pipe for damage, security of mounting, and missing components.</p> <p>e. Check fuel filter for leaks or damage.</p>	<p>a. Heater inoperable and mission requires heater.</p> <p>b. Class III fuel leakage is evident and mission requires heater.</p> <p>c. Wires frayed or broken.</p> <p>d. Heater exhaust damaged or components missing.</p> <p>e. Class III leak evident.</p>

Table 2-2. Preventive Maintenance Checks and Services (Cont'd).

Item No.	Interval	Location	<u>Crewmember</u> Procedure	Not Fully Mission Capable If:
		Item to Check/Service		
46	Weekly	Air Cleaner	<p><u>DRIVER</u></p> <p><u>WARNING</u></p> <p>If NBC exposure is suspected, all air filter media should be handled by personnel wearing protective equipment. Consult your unit NBC officer or NBC NCO for appropriate handling or disposal instructions.</p> <p>Check air cleaner weathercap, air cleaner assembly, air intake hose, and air horn for security of mounting and damage.</p>	Damage to air cleaner weathercap, body, air intake hose, or mounting allows unfiltered air to enter the engine.
47	Weekly	Alternator Brackets	<p><u>DRIVER</u></p> <p>Visually check power steering and alternator brackets for cracks, damage, or loose bolts.</p>	Bracket is cracked or bolts damaged or loose.
48	Weekly	Cooling System	<p><u>DRIVER</u></p> <p>a. Check fan and fan pulley for damage.</p> <p>b. Check radiator for leaks, clogged or damaged fins, and loose or damaged hoses to and from the engine.</p> <p>c. Check support mounts on radiator for damage.</p>	<p>a. Fan blade or pulley is bent, broken, cracked, or loose.</p> <p>b. Class III leakage evident.</p> <p>c. Support mounts damaged or broken.</p>

Table 2-2. Preventive Maintenance Checks and Services (Cont'd).

Item No.	Interval	Location	Crewmember Procedure	Not Fully Mission Capable If:
		Item to Check/Service		
48	Weekly	Cooling System (Cont'd)	<p>d. Check serpentine belt if missing, broken, cracked, or frayed.</p> <p>e. Check fan shroud for damage.</p> <p>f. Check engine oil cooler and hoses for damage and leaks.</p>	<p>d. Serpentine belt is missing or broken. Belt fiber has more than one crack 1/8 in. (3.2 mm) in depth or 50% or frays more than 2 in. (5.1 cm) long.</p> <p>e. Fan shroud broken, cracked, or loose.</p> <p>f. Class III leak evident.</p>
49	Weekly	Batteries	<p><u>DRIVER</u></p> <p style="text-align: center;"><u>WARNING</u></p> <ul style="list-style-type: none"> • Do not smoke, have open flames, or make sparks around batteries, especially if the caps are off. Batteries can explode and may cause injury or death. • Remove all jewelry such as rings, dog tags, bracelets, etc. If jewelry contacts battery terminal, a direct short may result, causing severe injury to personnel, or damage to equipment. <p>a. Remove companion seat and check batteries for damaged casing, terminal posts, and security of mounting. Notify unit maintenance if any defects are found.</p>	<p>a. One or more batteries missing, un-serviceable, or leaking; terminal or cables loose, corroded, or holddowns not secure.</p>

Table 2-2. Preventive Maintenance Checks and Services (Cont'd).

Item No.	Interval	Location	<u>Crewmember</u> Procedure	Not Fully Mission Capable If:
		Item to Check/Service		
49	Weekly	Batteries (Cont'd)	<p>b. Electrolyte should be filled to the level/split ring in the battery filler opening (vent). If fluid is low, fill with distilled water to split ring (appendix D, item 7). If fluid is gassing (boiling), notify unit maintenance.</p> <p>c. Check battery box for corrosion. Clean debris from battery box drain holes.</p> <p><u>DRIVER</u></p>	
50	Weekly	Weapon Station	<p>a. Inspect weapon station hatch and hinge for bends, cracks, warped, or damaged areas.</p> <p>b. Inspect brake for ease of operation.</p> <p>c. Inspect gunner's sling for tears, frays, or damaged hook.</p> <p><u>DRIVER</u></p>	<p>a. Hatch or hinges inoperable.</p> <p>b. Brake does not operate.</p> <p>c. Sling is torn, shows wear, or hook is damaged.</p>
51	Weekly	Tiedowns	<p>a. Inspect stored equipment footman loops for presence and security of mounting. Inspect straps for tears or frays.</p> <p>b. Inspect stowage brackets, footman loops, and tiedowns for security of mounting, damage, and missing components.</p> <p>c. Inspect all tiedown strap assemblies for proper operation, frays, damage, cleanliness, and security of mounting.</p>	

Table 2-2. Preventive Maintenance Checks and Services (Cont'd).

Item No.	Interval	Location	Crewmember Procedure	Not Fully Mission Capable If:
		Item to Check/Service		
52	Weekly	Tow Pintle	<p><u>DRIVER</u></p> <p>Check pintle hook for looseness, damaged locking mechanism, and presence of cotter pin.</p>	
53	Weekly	Environment Control System	<p><u>DRIVER</u></p> <p>(M1114 only)</p> <p>a. Check security of windshield de-icer control box mounting.</p> <p>b. Check heating, ventilation, and air conditioning vents, and mounting hardware for damage, leaks, missing components, and security of mounting.</p> <p>c. Inspect exposed wiring harnesses for breaks, frayed insulation, loose or damaged connectors, and loose, damaged, or missing mounting hardware.</p>	<p>c. Wiring harness broken, frayed, or damaged. Mounting hardware missing.</p>
54	Weekly	Parking Brake	<p><u>DRIVER</u></p> <p>Check combination service/parking brake assemblies; inspect parking brake for obstruction of the actuating lever or broken or missing spring.</p>	<p>Actuating lever or spring is broken or missing.</p>
55	Weekly	Windshield Washer	<p><u>DRIVER</u></p> <p>a. Visually check windshield washer reservoir for damage.</p> <p>b. Check windshield washer fluid level.</p>	
56	Monthly	Corrosion	<p><u>DRIVER</u></p> <p>Visually inspect vehicle for indication of corrosion or cracks and/or breaks.</p>	<p>Any corroded-through condition, cracks or breaks that would affect vehicle operation.</p>

Table 2-2. Preventive Maintenance Checks and Services (Cont'd).

Item No.	Interval	Location	Crewmember Procedure	Not Fully Mission Capable If:
		Item to Check/Service		
57	Monthly	Tailgate	<p><u>DRIVER</u></p> <p>Check tailgate for corroded-through condition and/or damage. If tailgate does not latch securely or is damaged, notify unit maintenance.</p>	Any corroded-through condition, or damage that would affect vehicle operation.
58	Monthly	Winch	<p><u>DRIVER</u></p> <p>a. Check winch controls for proper operation.</p> <p>b. Check winch cable for kinks, frays, or breaks.</p>	
59	Monthly	Zippers	<p><u>DRIVER</u></p> <p>a. Check canvas top and door zippers for corrosion and/or damage.</p> <p>b. Apply interlock lubricant (Zipperease) (appendix D, item 19) to canvas top and door zippers.</p>	

Section III. OPERATION UNDER USUAL CONDITIONS

2-9. GENERAL

This section provides instructions for vehicle operations under moderate temperature, humidity, and terrain conditions. For vehicle operation under unusual conditions, refer to section IV of this chapter.

2-10. OPERATION UNDER USUAL CONDITIONS REFERENCE INDEX

REF. PARA.	TITLE	PAGE NO.
2-11.	Break-in Service	2-62
2-12.	Starting the Engine	2-62
2-13.	Placing Vehicle in Motion	2-66
2-14.	Stopping the Vehicle and Engine	2-68
2-15.	Operation of Vehicle Light Switch	2-70
2-16.	Adjusting Driver's Seat	2-72
2-17.	Companion Seat Assembly and Battery Box Cover Replacement	2-73
2-18.	Seatbelt Operation	2-74
2-19.	Defroster Operation (M1113)	2-75
2-20.	Defroster Operation (M1114)	2-76
2-21.	Heater Operation	2-77
2-22.	Tailgate Operation	2-78
2-23.	Slave Starting Operation	2-79
2-24.	Max Tool Kit Stowage (M1113) Operation	2-80
2-25.	Max Tool Kit Stowage (M1114) Operation	2-82
2-26.	Towing Operation	2-84
2-27.	Trailer Towing	2-89
2-28.	Electric Winch Operation	2-90
2-29.	Fire Extinguisher Operation	2-94
2-30.	Crew Door Operation (M1114)	2-95
2-31.	C-Pillar Door Operation (M1114)	2-96
2-32.	Cargo Shell Door Operation (M1114)	2-97
2-33.	Up-armored Weapon Station Operation (M1114)	2-98
2-34.	Fuel Door Operation (M1114)	2-100
2-35.	Air Conditioner Operation (M1114)	2-101
2-36.	Windshield De-icer Operation (M1114)	2-102

2-11. BREAK-IN SERVICE

NOTE

Before you operate your vehicle, be sure to perform the Preventive Maintenance Checks and Services (PMCS) shown in table 2-2.

a. Perform all break-in service before operation checks and services as indicated in table 2-2.

b. Upon receipt of vehicle, or after engine replacement, the following break-in speeds and precautions should be observed during the first 500 mi (805 km) of operation:

- Do not exceed a speed of 55 mph (89 kph).
- Do not drive for long periods of time at constant speed.
- Avoid rapid acceleration or deceleration.
- Drive at a moderate speed until the engine is fully warmed up.
- Do not tow trailer.

2-12. STARTING THE ENGINE

WARNING

- The automatic transmission has a PARK position. Never use the shift lever in place of the parking brake. Set the parking brake. Make sure the transmission shift lever is in the P (park) position and transfer case shift lever is NOT in the N (neutral) position. Damage to equipment and injury to personnel may occur if these instructions are not followed.
 - Chock blocks will be used when parking a vehicle with inoperative parking brakes, operating in extreme cold conditions, parking on inclines, or whenever and wherever maintenance is being performed. Failure to do so may result in injury to personnel or damage to equipment.
 - Hearing protection is required for driver and passengers when engine is running. Noise levels produced by these vehicles exceed 85 dBA, which may cause injury to personnel.
- a. Ensure parking brake is applied.
 - b. Adjust driver's seat (para. 2-16).
 - c. Adjust left and right rearview mirrors. Ensure both mirrors provide a clear view (para. 3-24).
 - d. Ensure all windows are clean. If not, clean windows before attempting to move vehicle (table 2-1).

WARNING

Ensure all slack from seatbelt is removed. Seatbelt retracts and will lock only during sudden stops or impact. Injury to personnel will result if an accident occurs and seatbelt is not used or adjusted properly.

NOTE

Fasten unused seatbelts to protect the belt ends from damage or dirt contamination.

- e. Fasten and adjust seatbelt (para. 2-18).

CAUTION

- Do not leave rotary switch in RUN position for extended periods of time. Glow plugs will continue to cycle and batteries will discharge leading to a no-start condition.
 - Glare from the sun may make it difficult to tell if the wait-to-start lamp assembly is illuminated. If this occurs, shade the light with your hands to ensure that the wait-to-start lamp assembly goes out before attempting to start the vehicle.
 - Starting the engine before the wait-to-start lamp goes out can result in starting problems.
- f. Turn rotary switch (1) to RUN and wait until wait-to-start lamp assembly (2) goes out.

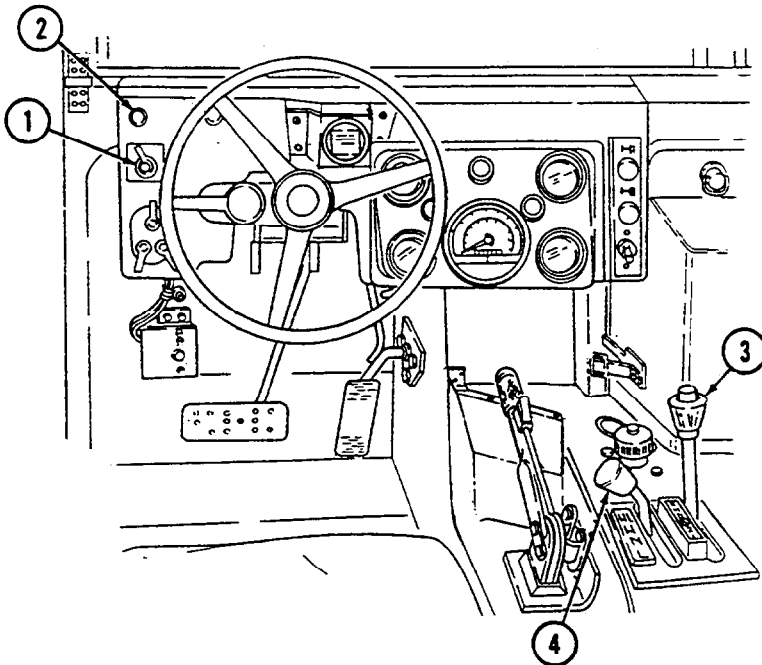

2-12. STARTING THE ENGINE (Cont'd)

CAUTION

- If ambient temperature is above 0°F (-18°C), do not operate starter continuously for more than 20 seconds; wait 10 to 15 seconds between periods of starter operation. Failure to do this may result in damage to the starter.
 - If any instrument reading is not normal, stop engine. Failure to do this may result in damage to the engine. Refer to troubleshooting, table 3-1.
 - If engine does not start, leave rotary switch in RUN position and wait 10 to 15 seconds before trying to restart. Failure to do this may result in damage to glow plugs or starter.
 - If you accidentally turn the rotary switch to ENG STOP position after an unsuccessful attempt to start, wait 90 seconds before trying to restart. Failure to do this may result in damage to glow plugs.
- g. Place rotary switch (1) to START. Release lever after engine starts. Lever will return automatically to RUN.

NOTE

Before the engine reaches operating temperature, the wait-to-start lamp may flicker and a clicking noise may be heard. This is due to glow plug relay cycling and is a normal condition.

- h. Allow engine to warm up for approximately one minute and ensure instruments indicate the following:
- (1) Oil pressure gauge (3) should register above approximately 6 psi (41 kPa) with engine at idle.
 - (2) Voltmeter (5) should register in green area.
 - (3) Fuel gauge (6) should indicate fuel level in fuel tank.
 - (4) Air restriction gauge (2) should not register within the red zone.
- i. Stop engine if any of the following conditions occur:
- (1) Excessive engine vibration.
 - (2) Oil pressure does not register or suddenly drops to or less than approximately 6 psi (41 kPa) with engine at idle.
 - (3) Air restriction gauge (2) is within the red zone.
- j. If engine overheating occurs:
- (1) Park vehicle, allow engine to idle.
 - (2) Observe coolant temperature gauge (4) for steady cooling.

CAUTION

Stop engine if coolant temperature gauge suddenly increases beyond approximately 230°F (110°C), or damage to engine will result.

- (3) If engine coolant temperature continues to increase, or does not decrease, as indicated by coolant temperature gauge (4), stop engine. Perform troubleshooting procedures in table 3-1.

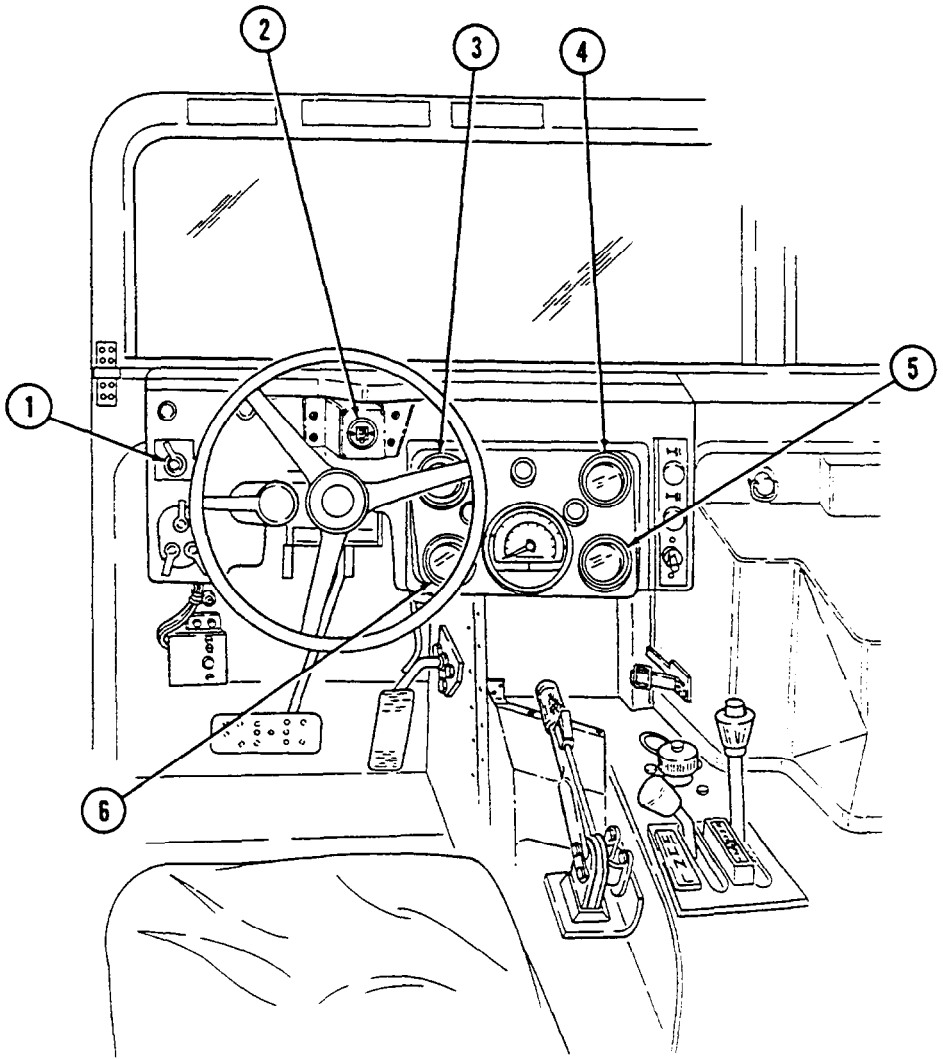

2-13. PLACING VEHICLE IN MOTION

WARNING

This vehicle has been designed to operate safely and efficiently within the limits specified in this TM. Operation beyond these limits are prohibited IAW AR 70-1 without written approval from the Commander, U.S. Army Tank-automotive and Armaments Command, ATTN: AMSTA-CM-S, Warren, MI 48397-5000.

NOTE

The following procedures apply to a vehicle being driven in good weather on high traction surfaces where little or no wheel slippage is evident. For operating the vehicle under unusual conditions; i.e., unusual terrain, cold weather, ice, snow, dusty or sandy areas, mud or rain, refer to section IV.

- a. Be sure all auxiliary equipment and tools are stored for travel.

CAUTION

- Vehicle must be stopped, and transmission shift lever placed in P (park) or N (neutral), before transfer case can be shifted. Failure to do this will result in damage to drivetrain.
 - Do not place transfer case shift lever in H/L (high/lock range) or L (low range) on high traction surfaces where little or no wheel slippage is evident, particularly when encountering sharp, continuous turns. Failure to operate the vehicle with transfer case in H (high range) on high traction surfaces, particularly when encountering sharp, continuous turns, can damage drivetrain.
- b. With transmission shift lever (2) in P, select H transfer case driving gear range using transfer case shift lever (3). This range is for normal driving in good weather or on high traction surfaces.
 - c. Start engine (para. 2-12).
 - d. Set vehicle light switch (7) (para. 2-15).

CAUTION

Ensure parking brake is released completely before operating the vehicle. Failure to do so may cause damage to equipment.

NOTE

If covering warning lamp with tape, put a pinhole in the tape to see when the light is on.

- e. Depress service brake pedal (6). Depress parking brake release button and release parking brake lever (4). The brake warning lamp assembly (1) should go out.

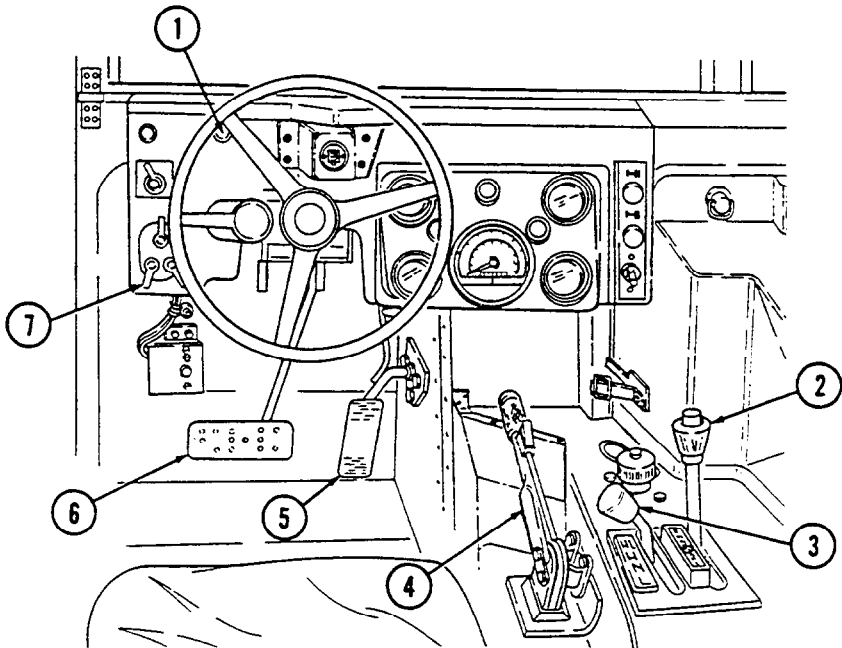

- f. Place transmission shift lever (2) in **(D)** (overdrive) for normal driving.
- g. Release service brake pedal (6), and depress accelerator pedal (5). Accelerate at a safe, steady speed.
- h. Upshift or downshift transmission shift lever (2) when road and/or traffic conditions change.

WARNING

Extreme caution shall be taken when transporting personnel. Rollover protection and seatbelts are available for the crew area only and are not provided in the troop/cargo area. Failure to use basic safe driving skills may result in injury or death to personnel and damage to equipment.

NOTE

To help judge clearance more accurately, guide rods can be used at the discretion of the unit commander.

- i. Exercise extreme caution when transporting personnel. Rollover protection is available for the crew area only and is not provided in the troop/cargo area. Although certain design characteristics of the vehicle, such as vehicle width, ground clearance, independent suspension, etc., provide improved capabilities, accidents can still happen.

2-13. PLACING VEHICLE IN MOTION (Cont'd)

WARNING

Vehicle speed must be reduced consistent with weather and road/terrain conditions. Obstacles such as stumps and boulders must be avoided. Failure to use basic safe driving techniques/skills may result in injury or death to personnel and damage to equipment.

j. Operators are reminded to observe basic safe driving techniques/skills when operating the vehicle, especially when transporting personnel.

2-14. STOPPING THE VEHICLE AND ENGINE

- a. Release accelerator pedal (5).
- b. Depress service brake pedal (6) to bring vehicle to a gradual stop.

WARNING

Never use the transmission shift lever in place of the parking brake. Set the parking brake. Make sure the transmission shift lever is in the P (park) position and transfer case shift lever is NOT in the N (neutral) position. Damage to equipment and injury to personnel may occur if these instructions are not followed.

- c. Once vehicle is completely stopped, apply parking brake lever (4).
- d. Move transmission shift lever (3) to P (park).
- e. Turn light switch (7) to OFF.
- f. Place rotary switch (1) to ENG STOP.

NOTE

If there is engine run-on, pinch the fuel return line with your fingers or a pair of pliers to stop the engine. Notify unit maintenance.

g. Lock steering wheel with cable (2), and chock wheels if tactical situation permits.

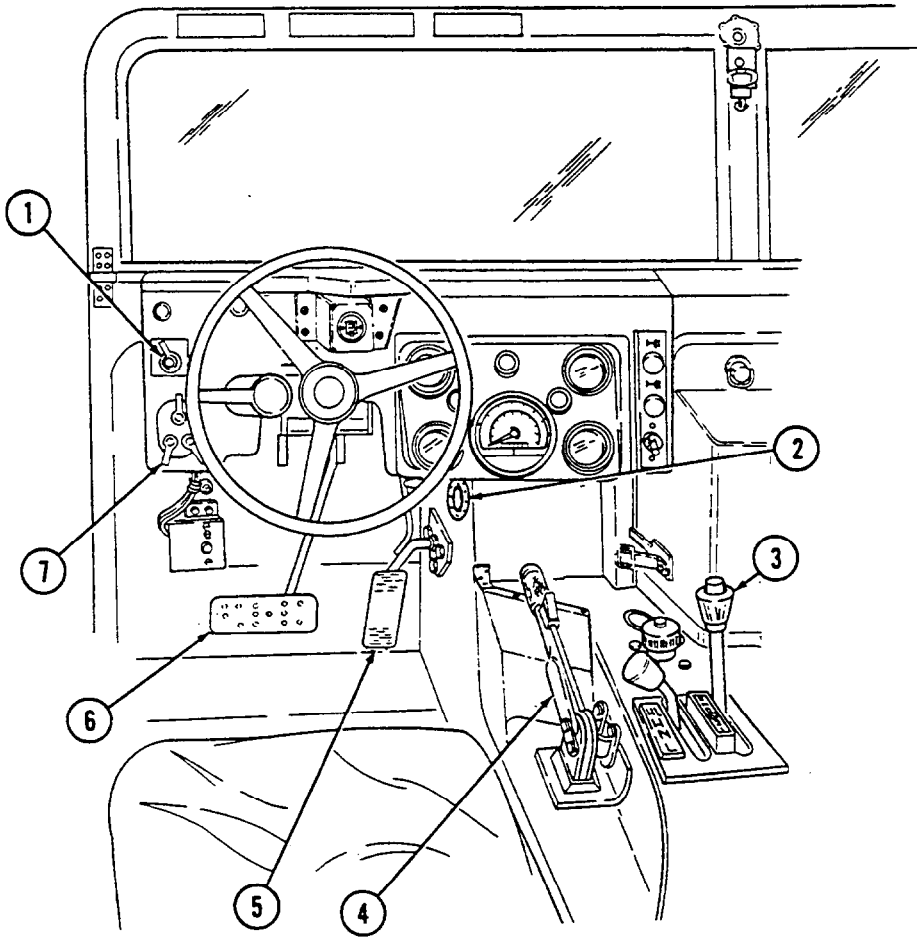

2-15. OPERATION OF VEHICLE LIGHT SWITCH

- a. To illuminate instrument panel:
 - (1) Lift unlock lever (2) to UNLOCK and hold in position.
 - (2) Turn selector switch lever (1) to any ON position except B.O. MARKER.
 - (3) Turn auxiliary lever (3) to DIM or PANEL BRT (bright).
- b. For normal daylight driving, turn selector lever (1) to STOPLIGHT.
- c. For night driving, turn selector lever (1) to SERVICE DRIVE. The headlight dimmer foot switch is depressed to provide high beam service light operation. The indicator light (4) on the instrument panel should illuminate when high beams are operating.
- d. In blackout operations:
 - (1) When driving vehicle, turn selector lever (1) to B.O. DRIVE.
 - (2) When vehicle is parked, turn selector lever (1) to B.O. MARKER.
- e. To illuminate parked vehicle at night (if tactical situation permits):
 - (1) Keep selector lever (1) in SERVICE DRIVE.
 - (2) Turn auxiliary lever (3) to PARK.
- f. Move turn signal lever up for right turns, and down for left turns.

NOTE

- When activated, the warning flashers override operation of the brake lights.
- The headlights cannot be turned on when auxiliary lever (3) is in the PARK position.

- g. For hazard warning lights (blinking lights):
 - (1) Turn selector lever (1) to SERVICE DRIVE or STOPLIGHT.
 - (2) Pull warning hazard tab out and move turn signal lever up to lock lever in place.
 - (3) To deactivate, move turn signal lever back to NEUTRAL.
- h. For horn operation, turn selector lever (1) to either STOPLIGHT or SERVICE DRIVE.

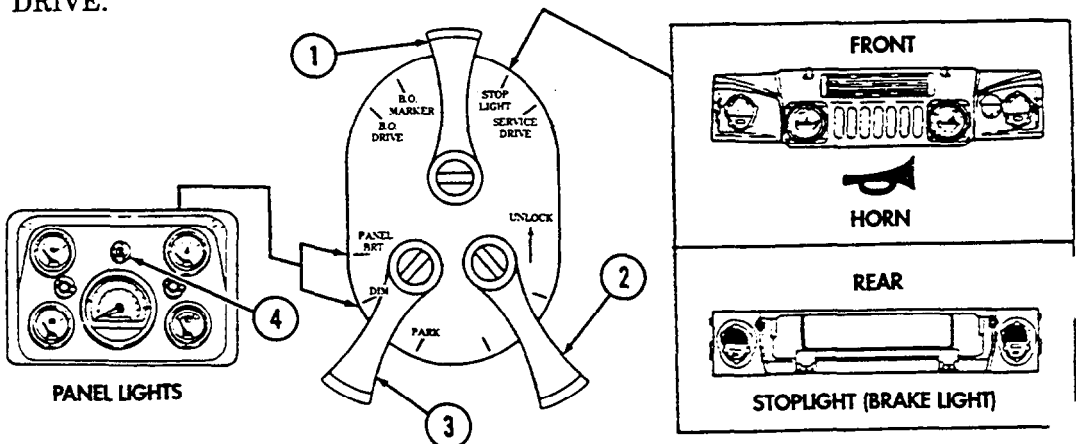

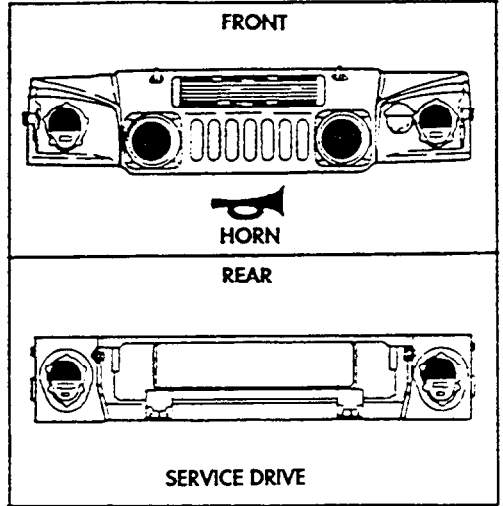
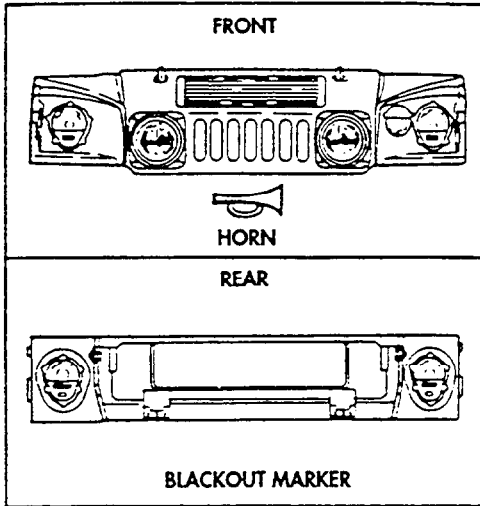

NOTE:

TO MOVE SELECTOR SWITCH LEVER FROM OFF TO ANY ON POSITION EXCEPT B.O. MARKER, UNLOCK SWITCH LEVER MUST BE LIFTED TO UNLOCK.

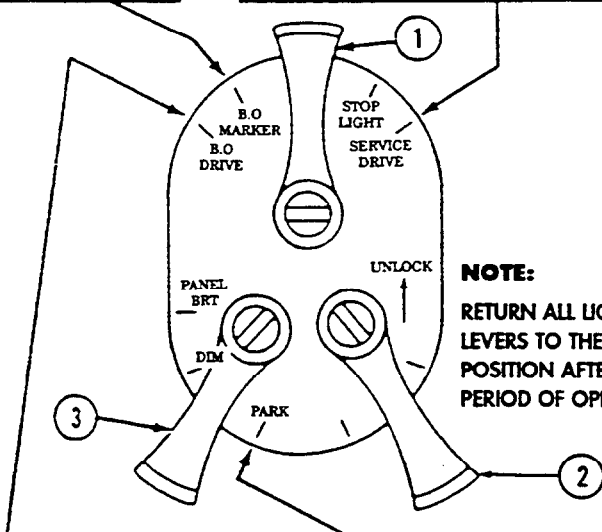

NOTE:

RETURN ALL LIGHT SWITCH LEVERS TO THE OFF POSITION AFTER EACH PERIOD OF OPERATION.

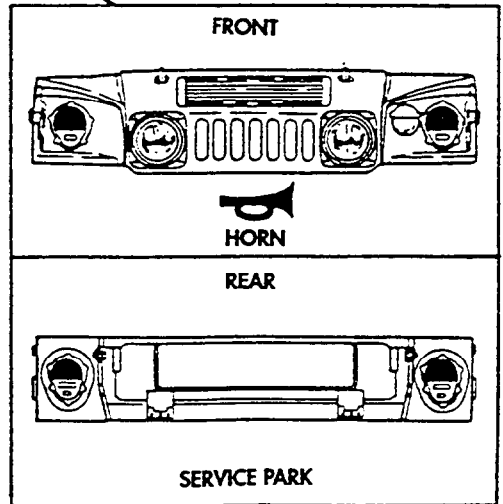
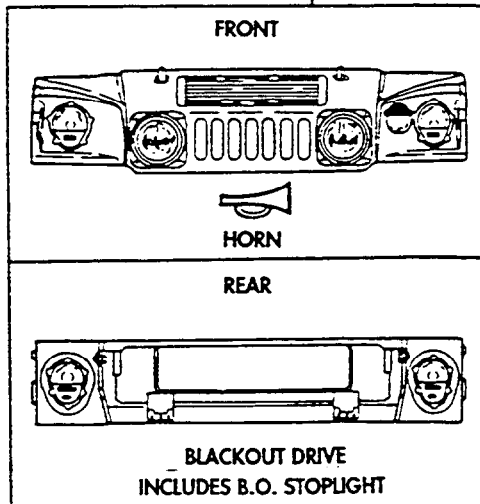

2-16. ADJUSTING DRIVER'S SEAT

a. Adjusting Seat Vertically.

- (1) Pull seat slide lever (2) upward and slide seat (3) to desired position.
- (2) Release seat slide lever (2) to lock seat (3) into position.

b. Adjusting Seat Horizontally.

- (1) To lower seat (3), pull seat height adjustment lever (1) upward and allow body weight to lower seat (3).
- (2) To raise seat (3), pull seat height adjustment lever (1) upward and remove body weight from seat (3).
- (3) Release seat adjustment lever (1) to lock seat (3) in desired position.

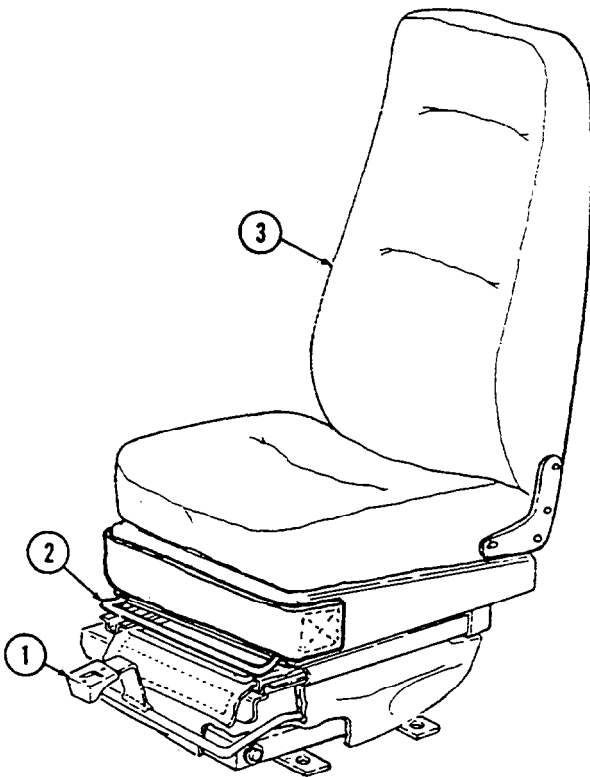

M1113

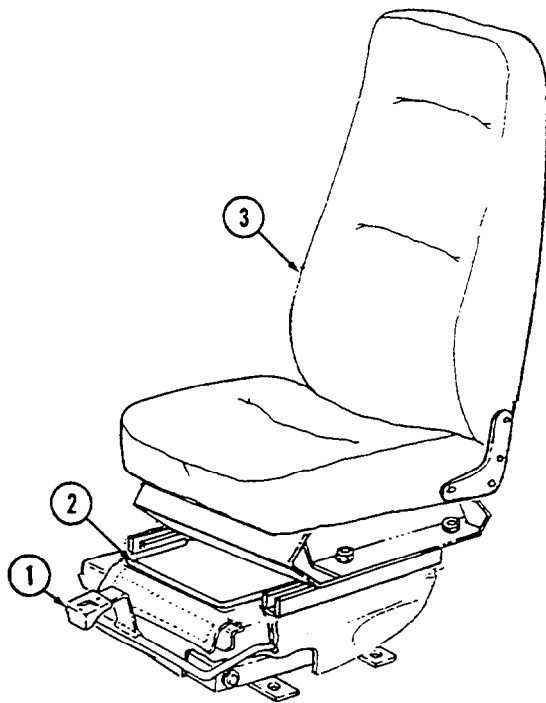

M1114

2-17. COMPANION SEAT ASSEMBLY AND BATTERY BOX COVER REPLACEMENT

a. Removal.

(1) Release two latches (3) from strikers (4) securing companion seat assembly (1) and battery box cover (5) to battery box (2).

(2) Lift and pull companion seat assembly (1) and battery box cover (5) forward and remove from battery box (2).

b. Installation.

(1) Install companion seat assembly (1) and battery box cover (5) on battery box (2).

(2) Secure seat assembly (1) and battery box cover (5) to battery box (2) by connecting two latches (3) to strikers (4).

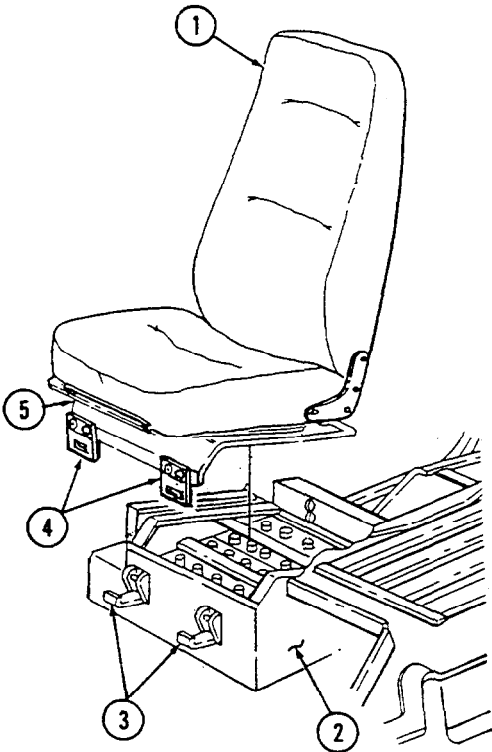

M1113

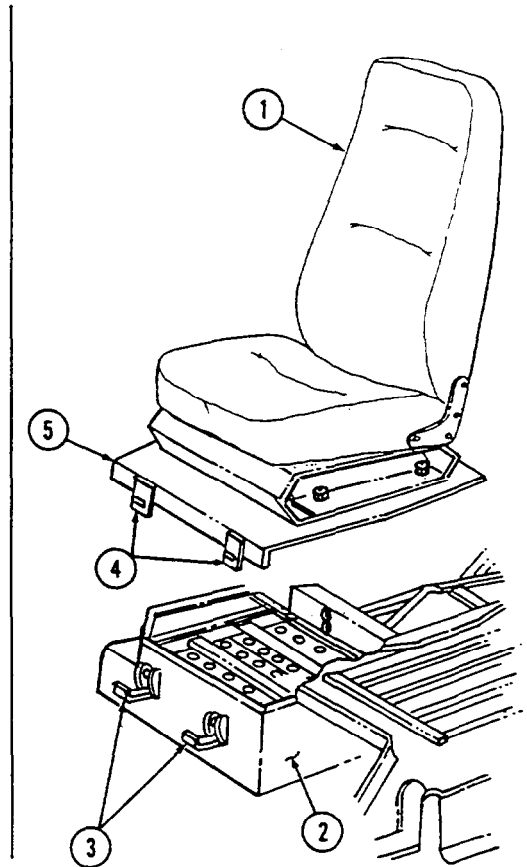

M1114

2-18. SEATBELT OPERATION

WARNING

Ensure all slack from seatbelt is removed. Seatbelt retracts and will lock only during sudden stops or impact. Injury to personnel will result if an accident occurs and seatbelt is not in use or adjusted properly.

a. Seatbelt Fastening. Pull shoulder harness and seatbelt (3) across body and fasten latch plate (2) to belt buckle (1).

b. Seatbelt Adjustment. Pull shoulder harness strap through latch plate (2) and remove slack from seatbelt (3). Seatbelt (3) must fit snugly across operator's and passenger's hips, shoulders, and chests.

c. Seatbelt Unfastening. Push release button (4) on belt buckle (1) to release seatbelt (3).

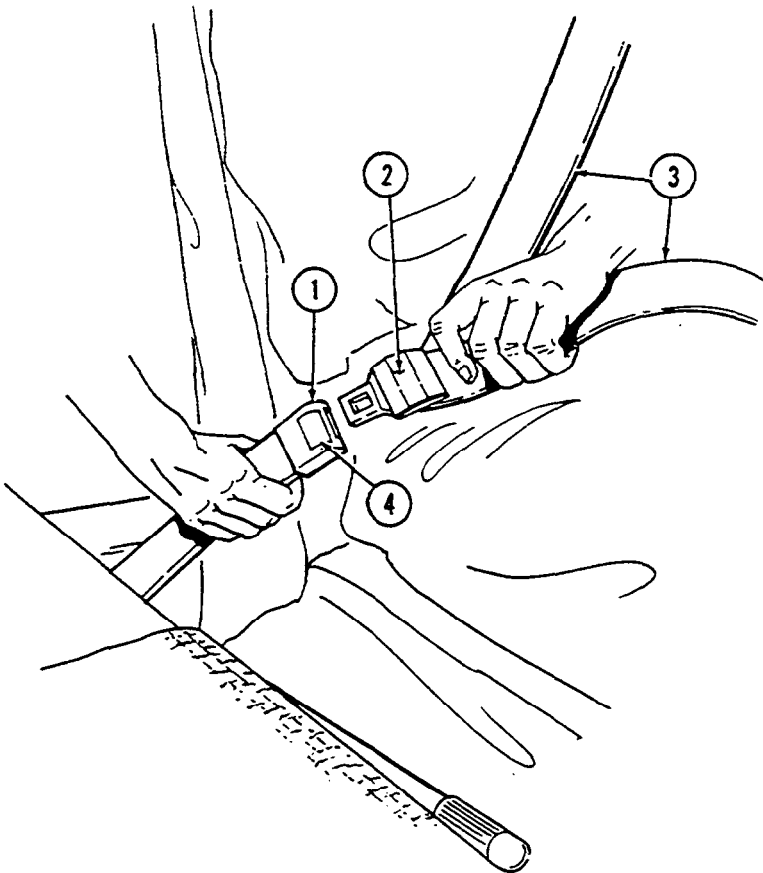

2-19. DEFROSTER OPERATION (M1113)

- a. Start engine (para. 2-12).
- b. Push fresh air intake lever (3) forward to close grille.
- c. Turn heater fan switch (4) to desired setting, HIGH/LOW.
- d. Position heater control knob (2) to desired setting.
- e. Push in defroster control knob (1).

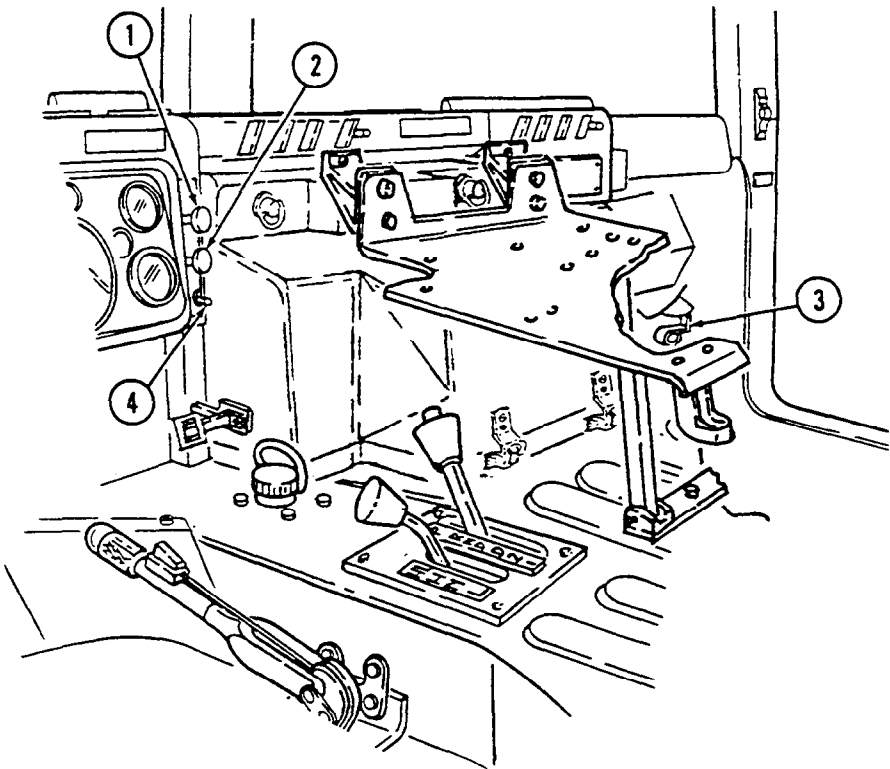

2-20. DEFROSTER OPERATION (M1114)

a. Operation.

- (1) Start engine (para. 2-12).
- (2) Slide defroster register (1) to the right to open defroster.
- (3) Pull fresh air control knob (2) in to close vents (5).
- (4) Position heater control knob (3) to desired setting.
- (5) Flip heater fan switch (4) up to turn on heater.

b. After Operation.

- (1) Flip heater fan switch (4) down to turn off heater.
- (2) Slide defroster register (1) to the left to close defroster.
- (3) Stop engine (para. 2-14).

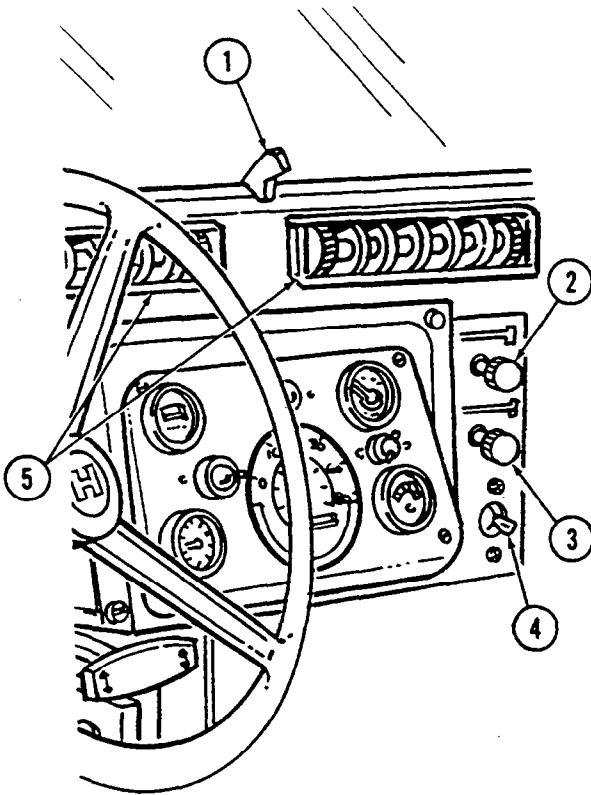

2-21. HEATER OPERATION

- a. Start engine (para. 2-12).

NOTE

Perform step b. for M1113 models only.

- b. Push fresh air intake lever (3) forward to close grille.
c. Turn heater fan switch (4) to desired setting, HIGH/LOW.

NOTE

For maximum heat, pull heater control knob all the way out.

- d. Position heater control knob (2) to desired setting.
e. To shut off outside air, pull out control knob (1).

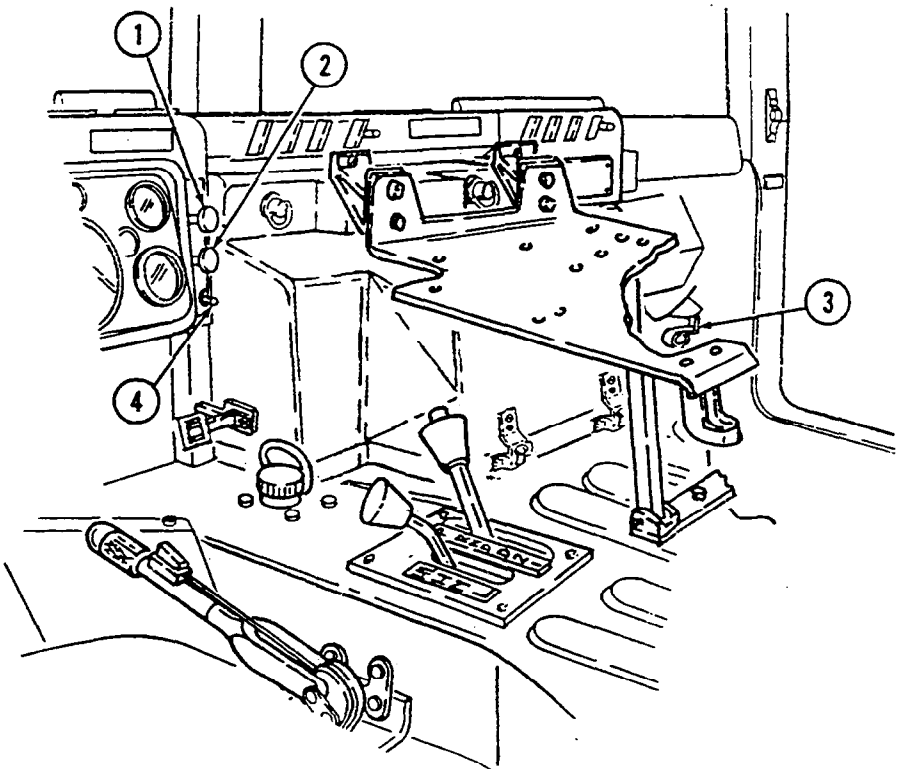

2-22. TAILGATE OPERATION

a. Lowering Tailgate.

CAUTION

The tailgate should not be lowered farther than the length of tailgate chains. Tailgate chains should always be used to support tailgate when open. Do not allow tailgate to slam against lifting shackles. Damage to equipment may occur.

(1) Remove two tailgate chain hooks (2) securing tailgate (1) to rear of vehicle body.

(2) Lower tailgate (1) and secure with two tailgate chain hooks (2).

b. Raising Tailgate.

(1) Raise two tailgate chain hooks (2) and raise tailgate (1).

(2) Secure tailgate (1) to rear of vehicle body with two tailgate chain hooks (2).

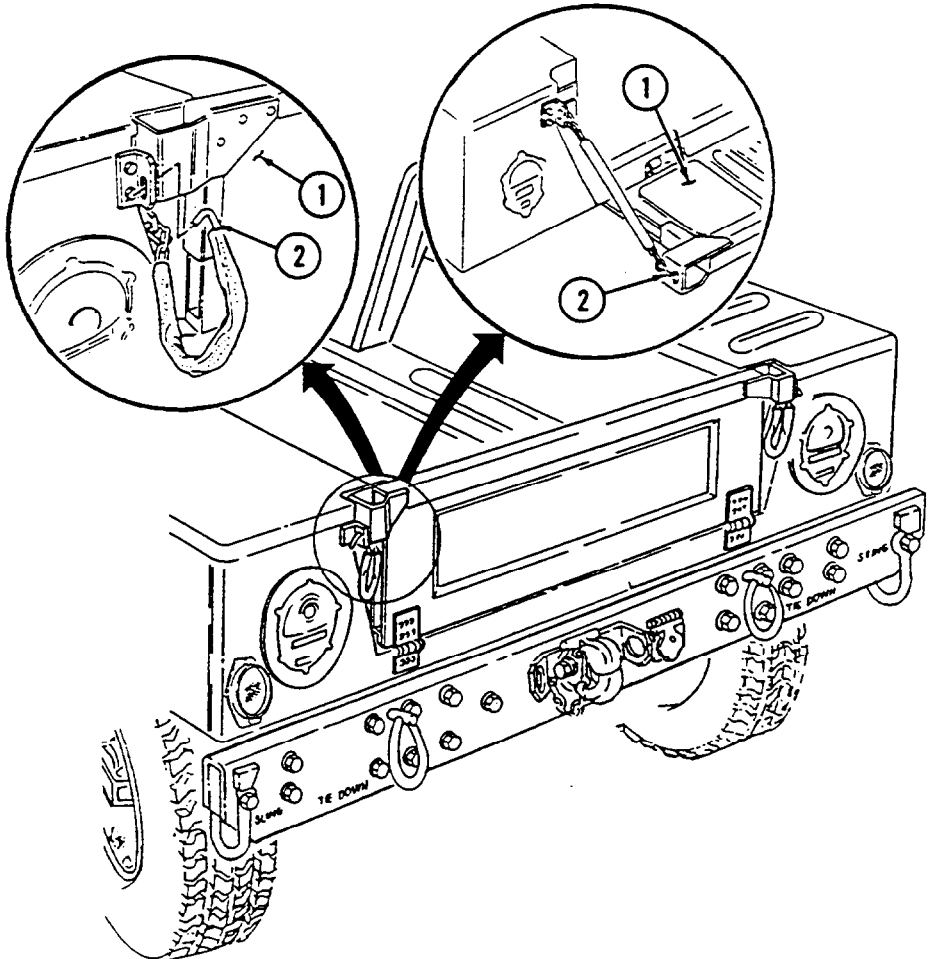

2-23. SLAVE STARTING OPERATION

- a. Position slaving vehicle and disabled vehicle close enough for cable hookup.
- b. Stop slaving vehicle engine.
- c. Remove cover from slave receptacle of disabled vehicle and slaving vehicle.

WARNING

Ensure all battery cables in disabled vehicle are properly connected before connecting slave cable. Damage to batteries, cables, or serious injury to personnel may result from improperly connected batteries.

CAUTION

Use a twisting motion when installing slave cable to the receptacle. Forcefully pushing the cable onto the receptacle may cause damage to the receptacle mount.

NOTE

Ensure all electrical switches in both vehicles are turned off.

- d. Connect slave cable to the slave receptacle of both vehicles.
- e. Start slaving vehicle engine.
- f. Start disabled vehicle engine.

CAUTION

Use a twisting motion when disconnecting slave cable from the receptacle. Forcefully pulling the cable from the receptacle may cause damage to the receptacle mount.

- g. After engine starts, disconnect slave cable from both vehicles.

NOTE

For ease of removal, apply hand cleaner (appendix D, item 16) on the inside of the cover before installing receptacle covers.

- h. Install receptacle covers on both vehicles.

2-24. MAX TOOL KIT STOWAGE (M1113) OPERATION

a. Tool Removal.

(1) Disconnect three strap assemblies (2) in right footwell area (1) securing ax (4), max tool carrying bag (5), and jack and tools bag (3). Remove ax (4) and max tool carrying bag (5).

(2) Remove the following attachments from max tool carrying bag (5):

- Reversible rake/hoe attachment (12)
- Rake/hoe thumbscrew attachment (11)
- Shovel attachment (6)
- Six safety locking pins (8)
- Broad pick attachment (10)
- Pick attachment (9)
- Mattock attachment (7)

NOTE

- Using the ax and attachments, the max tool kit can be incorporated into seven basic hand tools.
- Ax blade must be covered with sheath before using kit.
- Read all safety and assembly instructions enclosed with max tool kit before using kit.

b. Reversible Rake/Hoe Attachment.

(1) Connect rake/hoe attachment (12) (with either rake or hoe in the working position) into socket (13) on end of ax (4).

NOTE

Thumbscrew must be seated tightly in rake/hoe attachment and socket of ax. Check thumbscrew often to be sure it does not work loose.

(2) Install thumbscrew (11) on rake/hoe attachment (12) and in socket (13) of ax (4). Tighten thumbscrew (11).

(3) To remove rake/hoe attachment (12), remove thumbscrew (11) from rake/hoe attachment (12) and ax (4).

c. Shovel Attachment.

NOTE

Shovel attachment is shown. Broad pick, pick, and mattock attachments are attached basically the same.

(1) Connect shovel attachment (6) into socket (13) on end of ax (4).

(2) Insert safety locking pin (8) into hole in end of taper on shovel attachment (6).

(3) To remove shovel attachment (6), remove safety locking pin (8) from shovel attachment (6) and ax (4).

d. Tool Installation.

(1) Replace attachments in the max tool carrying bag (5).

(2) Install max tool carrying bag (5) and jack and tools bag (3) with three strap assemblies (2) in right footwell area (1) of vehicle.

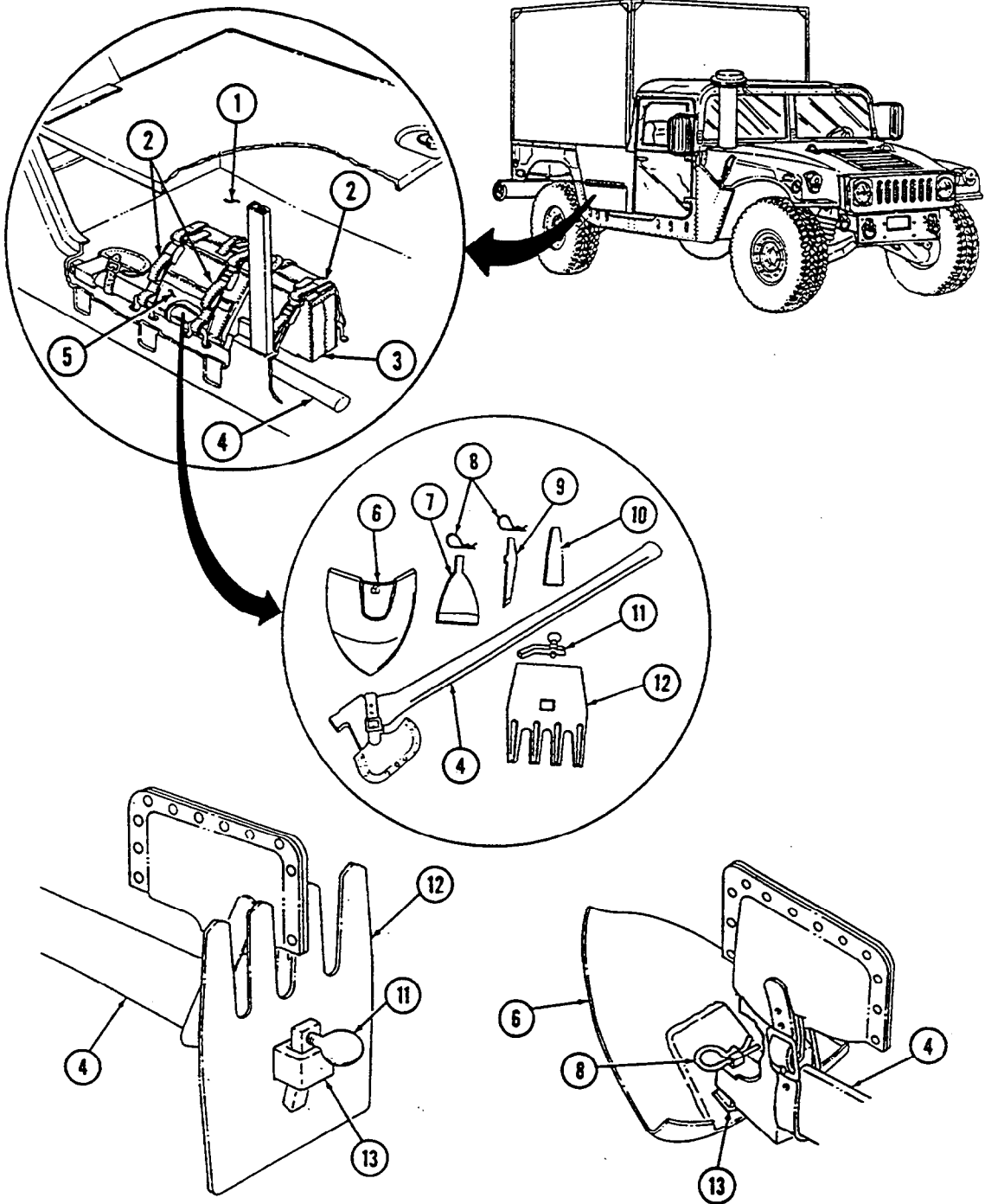

**REVERSIBLE RAKE/HOE
ATTACHMENT**

SHOVEL ATTACHMENT

2-25. MAX TOOL KIT STOWAGE (M1114) OPERATION

a. Tool Removal.

- (1) Open cargo shell door (para. 2-32).
- (2) Lower tailgate (para. 2-22).
- (3) Disconnect four strap assemblies (2) securing ax (3) and max tool carrying bag (1) to tailgate (4). Remove ax (3) and max tool carrying bag (1).
- (4) Remove the following attachments from max tool carrying bag (1):
 - Reversible rake/hoe attachment (11)
 - Rake/hoe thumbscrew attachment (10)
 - Shovel attachment (5)
 - Six safety locking pins (7)
 - Broad pick attachment (9)
 - Pick attachment (8)
 - Mattock attachment (6)

NOTE

- Using the ax and attachments, the max tool kit can be incorporated into seven basic hand tools.
- Ax blade must be covered with sheath before using kit.
- Read all safety and assembly instructions enclosed with max tool kit before using kit.

b. Reversible Rake/Hoe Attachment.

- (1) Connect rake/hoe attachment (11) (with either rake or hoe in the working position) into socket (12) on end of ax (3).

NOTE

Thumbscrew must be seated tightly in rake/hoe attachment and socket of ax. Check thumbscrew often to be sure it does not work loose.

- (2) Install thumbscrew (10) on rake/hoe attachment (11) and in socket (12) of ax (3). Tighten thumbscrew (10).
- (3) To remove rake/hoe attachment (11), remove thumbscrew (10) from rake/hoe attachment (11) and ax (3).

c. Shovel Attachment.

NOTE

Shovel attachment is shown. Broad pick, pick, and mattock attachments are attached basically the same.

- (1) Connect shovel attachment (5) into socket (12) on end of ax (3).
- (2) Insert safety locking pin (7) into hole in end of taper on shovel attachment (5).
- (3) To remove shovel attachment (5), remove safety locking pin (7) from shovel attachment (5) and ax (3).

d. Tool Installation.

- (1) Replace attachments in max tool carrying bag (1).
- (2) Install max tool carrying bag (1) and ax (3) on tailgate (4) with four strap assemblies (2).
- (3) Raise tailgate (para. 2-22).
- (4) Close cargo shell door (para. 2-32).

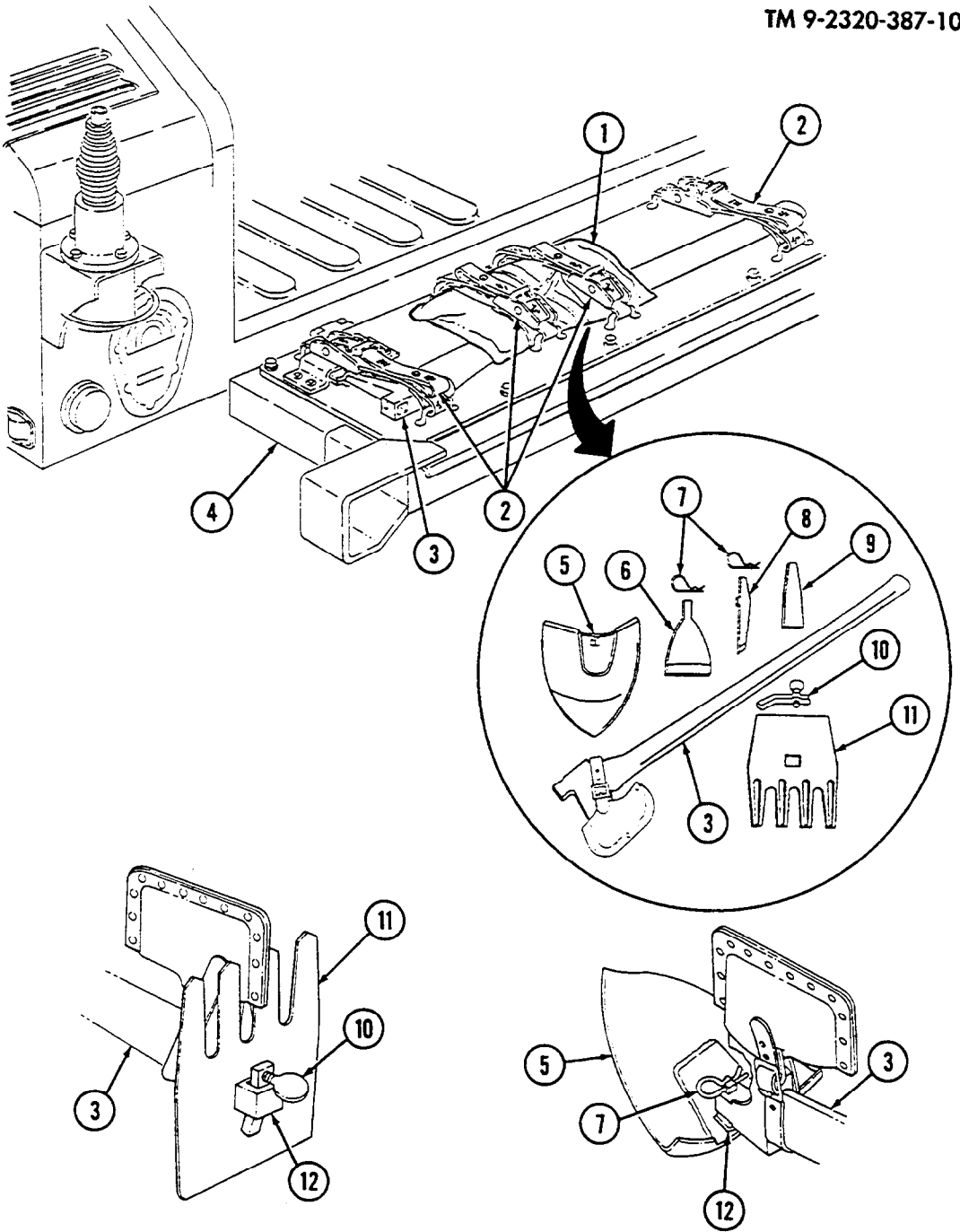

**REVERSIBLE RAKE/HOE
ATTACHMENT**

SHOVEL ATTACHMENT

2-26. TOWING OPERATION

CAUTION

- Do not exceed a towing speed of 30 mph (48 kph), or a towing distance of 30 mi (48 km), without first removing the front propeller shaft and/or rear propeller shaft, as specified in table 2-3. Failure to remove the necessary propeller shafts may result in damage to the transmission and/or transfer case.
- Before initiating vehicle recovery, operator should be familiar with basic vehicle recovery techniques and precautions. Refer to FM 20-22, Vehicle Recovery Operations.

NOTE

- Towing operations for M1113 and M1114 are basically the same.
- If propeller shafts are to be removed, notify unit maintenance personnel.
- Towing pintle (front bumper) provides improved driver control when moving trailers in hard-to-maneuver areas and during aircraft loading operations.

Table 2-3. Towing Operations.

Vehicle Towing Mode	Prop Shafts
Rear wheels up	Front off
Front wheels up	Rear off
Four wheels on ground	Front and rear off

a. Towing Vehicle from Front (Four Wheels on Ground).

CAUTION

Always use a towbar when towing vehicle. Failure to do so may cause damage to equipment.

- (1) Attach towbar (2) to the towing shackle brackets (4) of the vehicle to be towed and to the pintle hook (1) of the towing vehicle.
- (2) Attach safety chain (5) to vehicle frames directly behind bumper (3) or bumperette (6). Let safety chain (5) dip to about 1 ft (30.5 cm) from the ground.
- (3) If towing operation is over a distance of 30 mi (48 km), or towing speed is expected to be over 30 mph (48 kph), remove propeller shafts specified in table 2-3.
- (4) Place transmission and transfer case shift levers in N (neutral) (para. 2-13).
- (5) Depress parking brake release button and release parking brake lever (para. 2-13).
- (6) Proceed with towing operation. The vehicle is capable of towing a similar vehicle, fully loaded, for a distance of 50 mi (80 km).

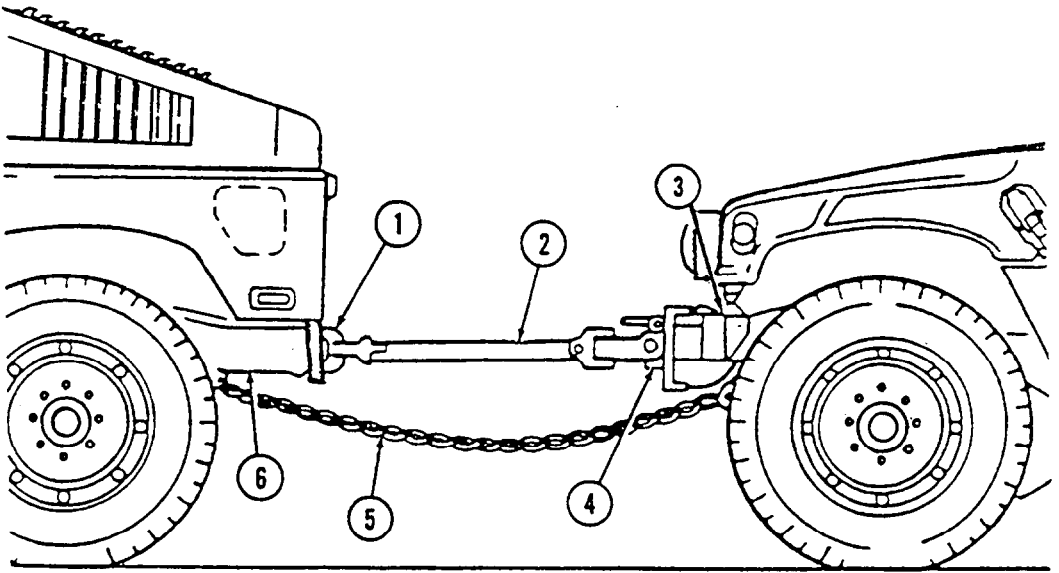

2-26. TOWING OPERATION (Cont'd)

b. Towing Vehicle from Front (Front Wheels Up).

NOTE

- Towing operations for M1113 and M1114 are basically the same.
- Ensure that towbar is connected to towing brackets as shown in illustration.

(1) Attach towbars (5) to brackets (1) and to wrecker towing pintle.

CAUTION

- Ensure that wrecker hoisting boom and hook are centered over the lifting shackles. Failure to do this may result in difficult turning during towing operations.
- Ensure safety chain is connected correctly to vehicles equipped with a front winch. Failure to do so may result in damage to front winch.

(2) Install chain assembly (3) through lifting shackles (2) and attach chain assembly (3) to the wrecker's hoisting hook (4).

(3) Secure safety chain (6) to towed vehicle's frame and to wrecker directly behind the bumper. Let safety chain (6) dip to about 1 ft (30.5 cm) from the ground.

(4) Hoist vehicle to be towed.

(5) If towing operation is more than a distance of 30 mi (48 km), or towing speed is expected to be over 30 mph (48 kph), remove propeller shaft as specified in table 2-3.

(6) Place transmission and transfer case shift levers in N (neutral) (para. 2-13).

(7) Depress parking brake release button and release parking brake lever (para. 2-13).

(8) Proceed with towing operation.

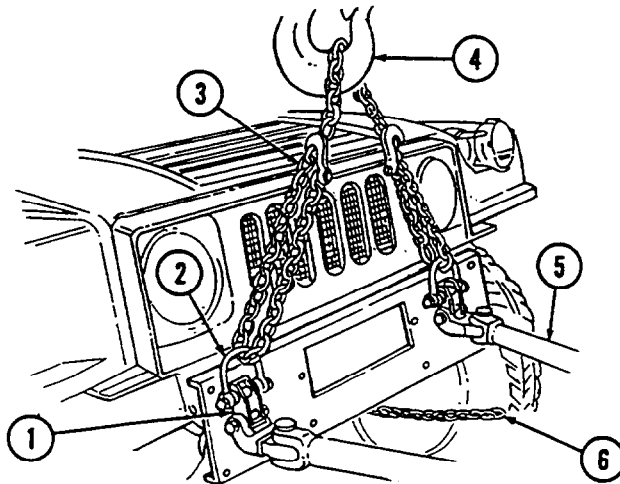

c. Towing Vehicle from Rear (Rear Wheels Up).

NOTE

It will be necessary to remove the wrecker lifting eyes (shackle) prior to attaching the towbar arms.

(1) Attach the eye of the towbar (5) to the pintle (7) of the vehicle requiring towing and the towbar arms to the wrecker rear lifting eye attaching bracket.

CAUTION

- Ensure safety chain is connected correctly to vehicles equipped with a rear winch. Failure to do so may result in damage to rear winch.
- Ensure that wrecker hoisting boom and hook are centered over the lifting shackles. Failure to do this may result in difficult turning during towing operations.

(2) Install chain assembly (3) through the rear lifting shackles (8) and attach the chain assembly (3) to the wrecker's hoisting hook (4).

(3) Secure safety chain (6) to towed vehicle's frame and to wrecker directly behind bumper. Let safety chain (6) dip to about 1 ft (30.5 cm) from the ground.

WARNING

Prior to towing vehicle with rear wheels up, secure steering wheel to prevent front wheels from turning. Failure to do this may cause damage to vehicle and injury or death to personnel.

(4) Secure steering wheel.

(5) If towing operation is more than a distance of 30 mi (48 km), or towing speed is expected to be over 30 mph (48 kph), remove front propeller shaft as specified in table 2-3.

(6) Place transmission and transfer case shift levers in N (neutral).

(7) Depress parking brake release button and release parking brake lever.

(8) Lift rear wheels from ground.

(9) Proceed with towing operations.

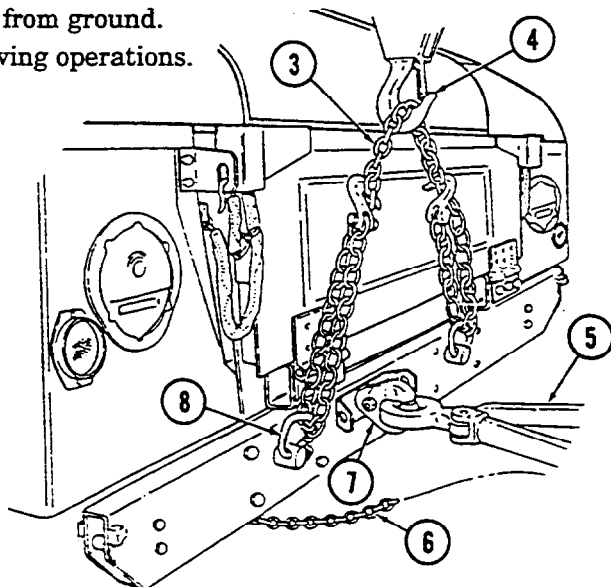

2-26. TOWING OPERATION (Cont'd)

d. Towing Shelter Vehicle from Rear (Rear Wheels Up).

NOTE

It will be necessary to remove the wrecker lifting eyes (shackle) prior to attaching the towbar arms.

(1) Attach the eye of the towbar (3) to the pintle (4) of the vehicle requiring towing and the towbar arms to the wrecker rear lifting eye attaching bracket.

CAUTION

Ensure that wrecker hoisting boom and hook are centered over the lifting shackles. Failure to do this may result in difficult turning during towing operations.

NOTE

If necessary, relocate the rear lifting shackles from the ends of the bumper to the location indicated.

(2) Install the two hooks of chain assembly (1) through the rear lifting shackles (6) and attach the chain assembly (1) to the wrecker's hoisting hook (2).

(3) Secure safety chain (5) to towed vehicle's frame and to wrecker directly behind bumpers and let safety chain (5) dip to about 1 ft (30.5 cm) from the ground.

WARNING

Prior to towing vehicle with rear wheels up, secure steering wheel to prevent front wheels from turning. Failure to do this may cause damage to vehicle and injury or death to personnel.

(4) Secure steering wheel.

(5) If towing operation is over a distance of 30 mi (48 km), remove front propeller shaft.

(6) Place transmission and transfer case shift levers in N (neutral) (para. 2-13).

(7) Depress parking brake release button and release parking brake lever (para. 2-13).

(8) Lift rear wheels from ground.

CAUTION

Do not exceed 15 mph (24 kph) towing speed. Avoid sharp turns and U-turns when towing. Failure to comply may cause damage to equipment.

(9) Proceed with towing operations.

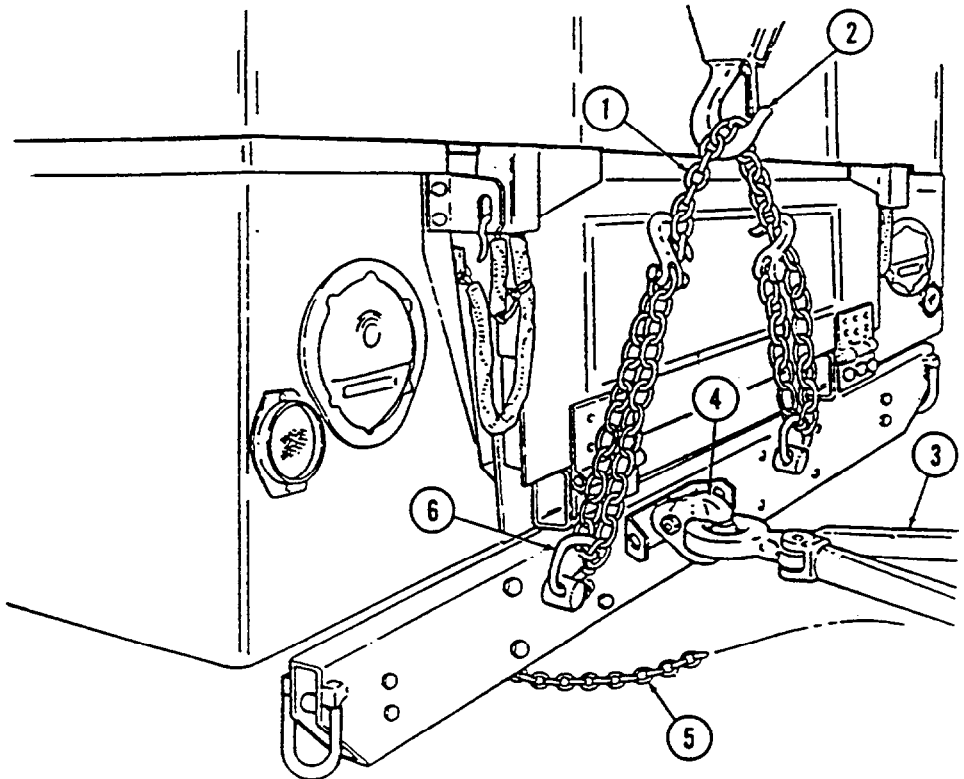

2-27. TRAILER TOWING

WARNING

Towing trailers too large or too small for the vehicle capacity is dangerous. These trailers do not track vehicle properly, cargo shifting occurs, and the likelihood of trailer capsizing during movement is increased. This could result in damage to equipment and injury or death to personnel.

CAUTION

Be sure to close tailgate before towing trailer. Failure to do so may cause damage to the master cylinder.

NOTE

- Towing any trailer with a HMMWV other than the authorized M116A1, M101A1, M1101, and M1102 trailers or a M102 howitzer is not authorized.
- When towing a trailer, the maximum safe slope is reduced from 40% to 30%.

The M1113 and M1114 vehicles are capable of towing a M116A1, M101A1, M1101, or M1102 trailer and the M102 howitzer. The M1113 and M1114 vehicles have a maximum towed load capacity of 4,200 lbs (1,907 kg). Trailer payloads should be evenly distributed to prevent excessive tongue loads.

2-28. ELECTRIC WINCH OPERATION

NOTE

The electric winch is an optional kit which may or may not be installed on the vehicle.

a. **General.** The vehicle electrical system is used to power the winch. It is recommended to have engine running while operating the winch so the alternator recharges the battery. Increased engine rpm can be maintained by use of the hand throttle. When engaging or disengaging the clutch, it may be necessary to rotate the drum by hand to align gears.

b. **Preparation for Use.**

- (1) Park vehicle directly facing object to be winched.
- (2) Apply parking brake (para. 2-13).
- (3) Start engine (para. 2-12).
- (4) Chock wheels.

c. **Unwinding Winch Cable.**

CAUTION

Do not power out winch cable for more than 10 ft (3 m). Use FREE SPOOL for paying out long lengths of winch cable. Failure to FREE SPOOL long lengths of winch cable may cause damage to winch.

- (1) Pull lever (4) out to FREE SPOOL.

WARNING

- Wear leather gloves when handling winch cable. Do not handle cable with bare hands. Failure to wear leather gloves may cause injury to hands.
- When fully extending winch cable, ensure that four wraps of winch cable remain on drum at all times. Failure to do this may cause injury, death to personnel, or damage to winch.

NOTE

Allow 1 ft (30.5 cm) of slack in winch cable prior to start of winching operations. This allows time for winch motor start up for maximum pulling power.

- (2) Pull cable (5) out by hand to desired length. Connect to load leaving 1 ft (30.5 cm) of slack in cable (5).

d. **Pulling Load.**

WARNING

Direct all personnel to stand clear of winch cable during winch operation. A snapped winch cable may cause injury or death.

NOTE

Refer to table 1-11, Winch Data, for pulling load capacity.

- (1) Install remote control switch (1) by connecting plug (2) to connector (3).
- (2) Push lever (4) in to ENGAGED.

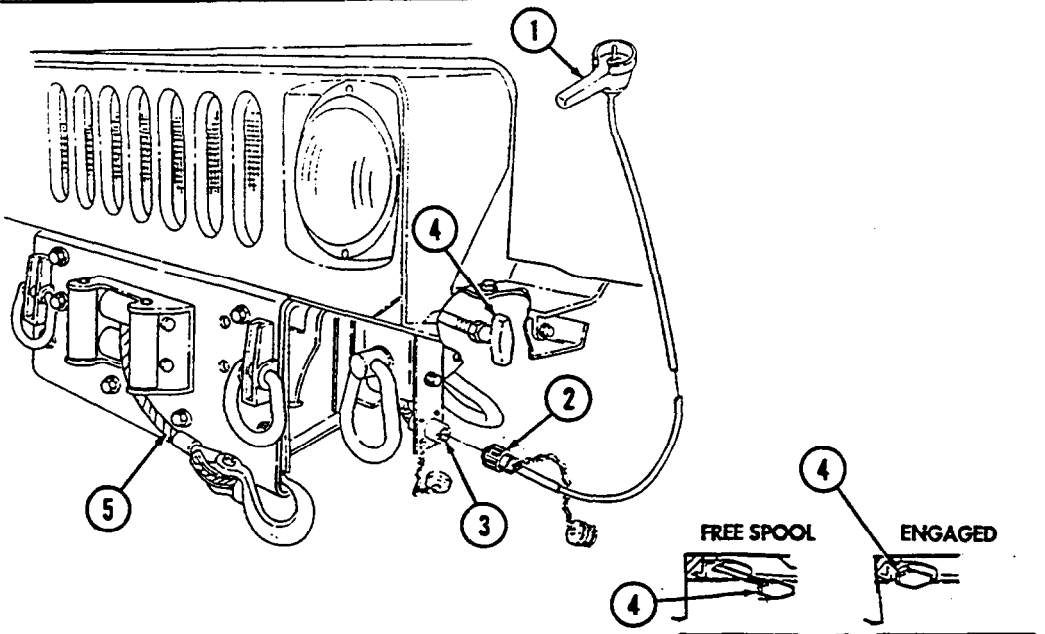
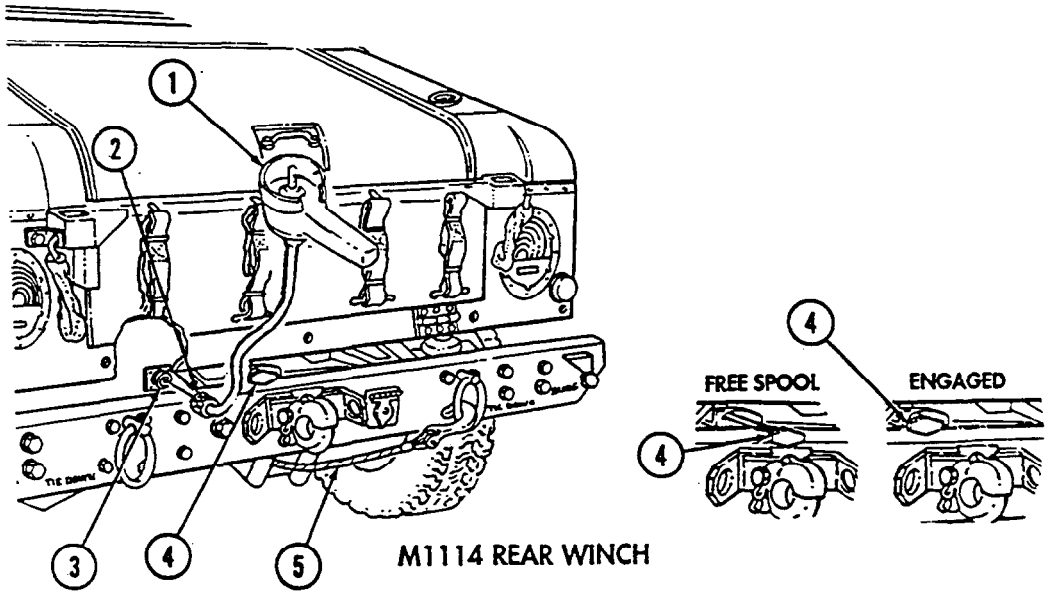

2-28. ELECTRIC WINCH OPERATION (Cont'd)

d. Pulling Load (Cont'd).

CAUTION

Do not fully apply hand throttle during engine NO LOAD condition. Damage to engine may result.

NOTE

- The electric winch is equipped with an electronic current limiter switch to prevent winch overload. If winch stops repeatedly during operation and restarts in approximately five seconds, the electronic current limiter is being activated, indicating an overload condition.
- The electric winch is equipped with a thermal cutoff switch to prevent winch from overheating. If winch stops during operation, and does not restart within five seconds, wait approximately two minutes to let winch cool off and allow thermal switch to reset. If after five minutes winch is still inoperative, notify unit maintenance.
- Engine speed is maintained for battery charging only and will not change winch operating speed.

(3) Pull hand throttle (1) out until desired engine speed is obtained.

(4) Operate remote control switch (2) to IN or OUT until load has been retrieved.

e. Securing Winch After Operation.

CAUTION

Winch cable must be wound onto drum under a load of at least 500 lb (227 kg) or outer wraps will draw into the inner wraps and damage winch cable.

(1) Wind winch cable (6) until hook (7) is 4 ft (1.2 m) from cable guide (8).

(2) Pull lever (5) out to FREE SPOOL and rotate drum by hand to retrieve the remaining cable (6).

(3) Remove remote control switch (2) by disconnecting plug (3) from connector (4).

(4) Push lever (5) in to ENGAGED.

(5) Release hand throttle (1).

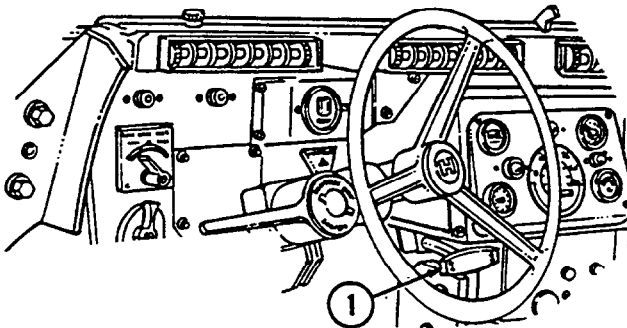

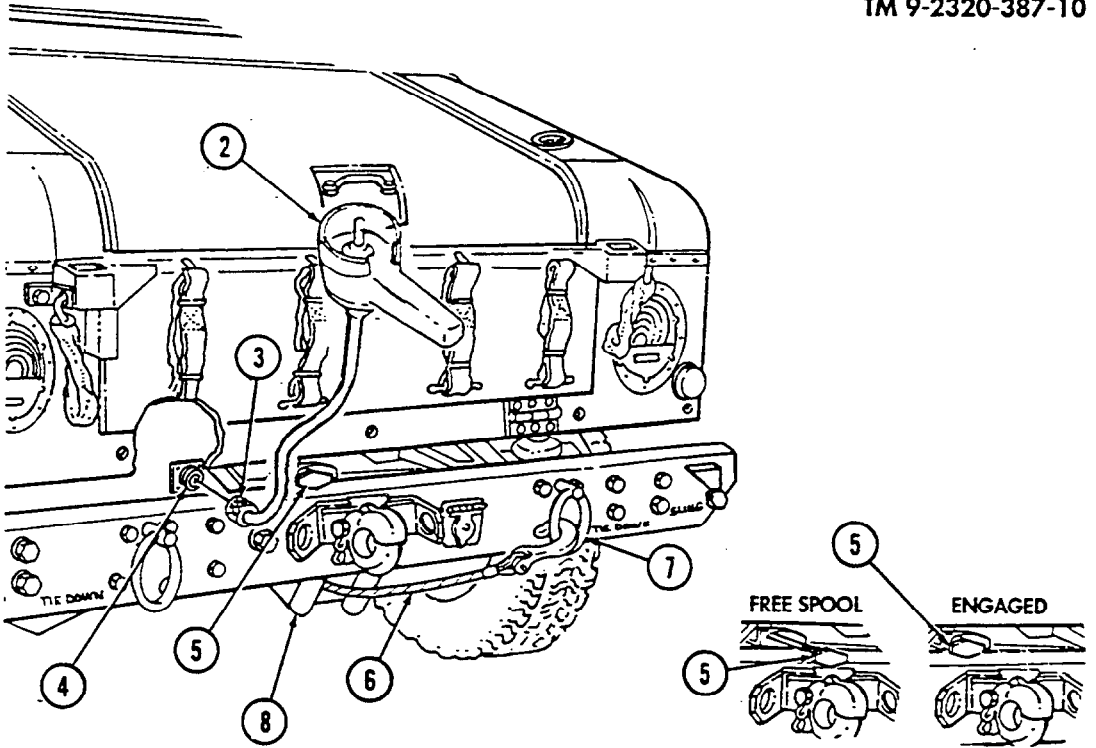

M1114 REAR WINCH

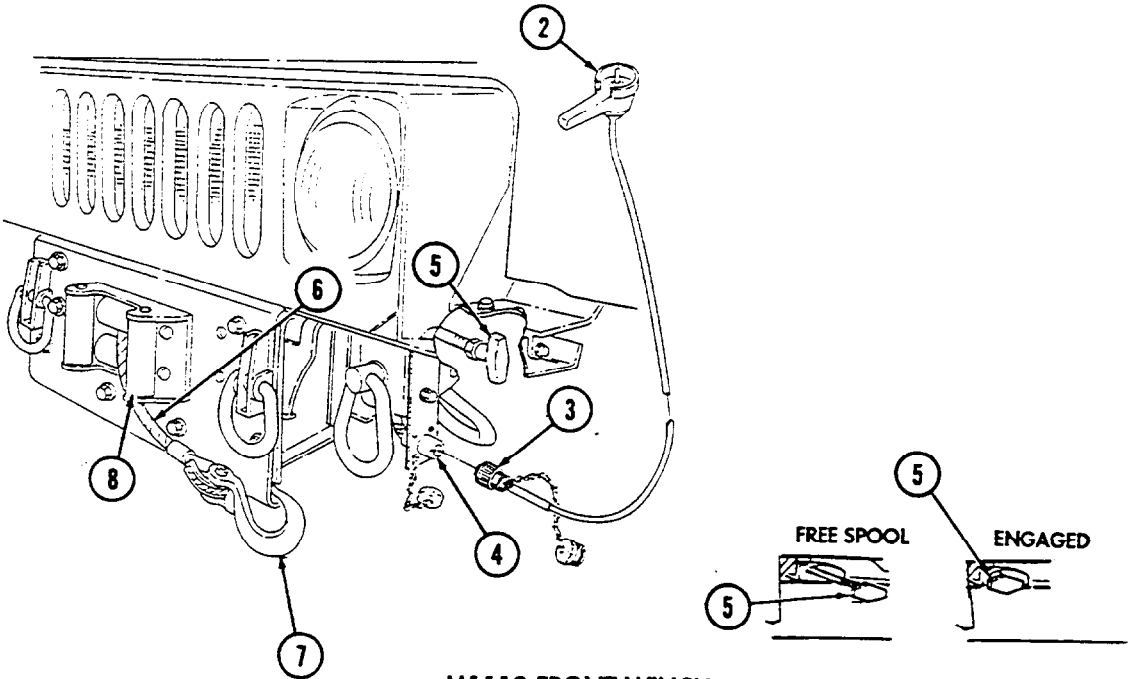

M1113 FRONT WINCH

2-29. FIRE EXTINGUISHER OPERATION

a. Before Operation.

- (1) Ensure operator PMCS have been accomplished and needle of indicator gauge (1) is in the green zone. Refer to table 2-2.
- (2) Refer to para. 2-2a for fire extinguisher stowage location.

WARNING

- Avoid using fire extinguisher in unventilated areas. Prolonged inhalation exposure to extinguishing agent or fumes from burning materials may cause injury to personnel.
- Using fire extinguisher in windy areas will cause rapid dispersal of extinguishing agent and reduce effectiveness in fire control.

b. During Operation.

- (1) To operate fire extinguisher (4), remove from stowage bracket (5). Remove locking pin (2).
- (2) Squeeze handles (3) together and direct extinguishing agent to base of flames. To extinguish burning liquid in a container, direct extinguishing agent against inside of container, just above burning liquid.

c. After Operation.

- (1) Stow fire extinguisher (4) in stowage bracket (5).
- (2) Notify unit maintenance to replace or recharge fire extinguisher (4) after use.

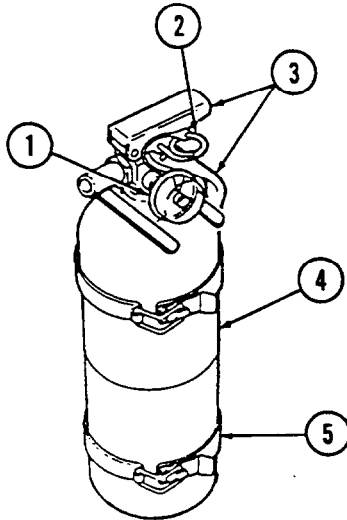

2-30. CREW DOOR OPERATION (M1114)

WARNING

Use care when opening and closing doors. Do not rest fingers in door opening. Personnel injury may result.

NOTE

Crew doors have a double-catch latching mechanism. Ensure door is completely closed and there is no gap between vehicle body and door.

- a. Open crew door (5) by turning handle (1) on outside of door (5). Pull door closed using strap handle (8) on inside of door (5).
- b. Lock door (5) by pushing in sliding door bar (6) into door latch cover (9) and turning sliding door bar (6) downward. Unlock door (5) by pulling sliding door bar (6) out of door latch cover (9) and turning sliding door bar (6) upward.
- c. Lift up on window locking bar (10) until it is clear of locking hole (3) in window frame (4). Slowly raise or lower window (2) to desired position. Engage window locking bar (10) into locking hole (3) in window frame (4).
- d. To exit vehicle, open door (5) by pulling up on door release handle (7) located on inside of door (5). Close door (5).

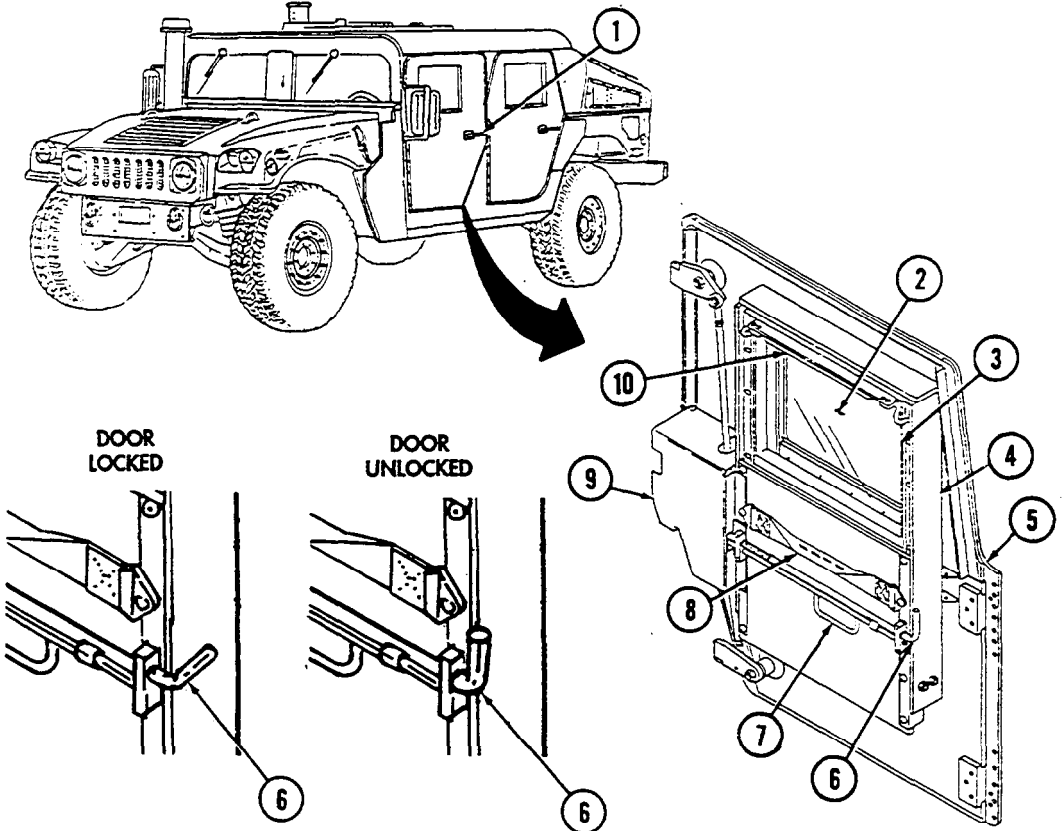

2-31. C-PILLAR DOOR OPERATION (M1114)

NOTE

Second locking point is a safety feature which prohibits door from accidentally closing upon objects protruding through door opening if the door is not in a locked position.

- a. To fully open, unlock C-pillar door (3) by depressing locking mechanism (1).
- b. Using handle (2), move door (3) to right, keeping locking mechanism (1) depressed while sliding past safety locking point (4).
- c. Release and engage locking mechanism (1) at far right. Door (3) is now secured.
- d. To partially close, release locking mechanism (1) and engage at the second safety locking point (4).
- e. Release and engage locking mechanism (1) at far left safety locking point (4). Door (3) is now secured.

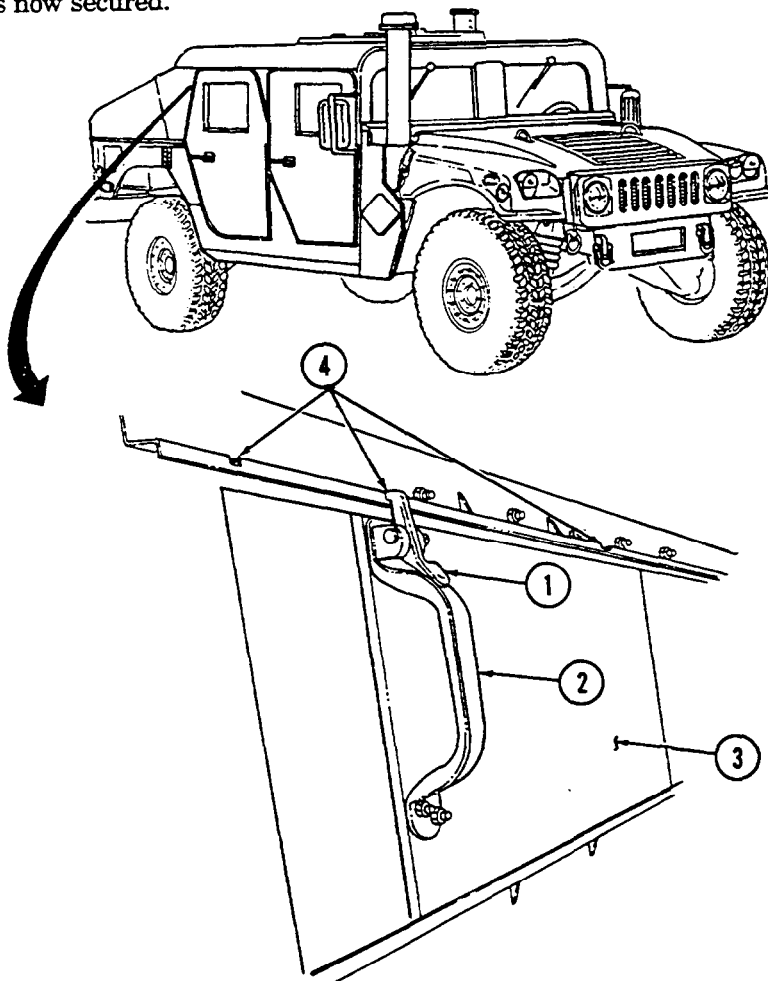

2-32. CARGO SHELL DOOR OPERATION (M1114)**WARNING**

Do not attempt to operate cargo shell door forward latch. The cargo shell door is not to be opened from inside the vehicle. Opening cargo shell door from inside the vehicle may cause damage to equipment or injury to personnel.

NOTE

For ease of operation, a grab-hold loop can be attached to the cargo door strap at the discretion of unit commander. Notify unit maintenance for installation of grab-hold loop.

a. Raising Cargo Shell Door.

Pull door handle (1) upward and release. Push door (2) open, until door (2) will open automatically to full open position.

b. Lowering Cargo Shell Door.

Pull on strap (3) to lower door (2) then slam shut. Ensure door (2) is locked by observing alignment of door surface with cargo shell surface side and bottom edges (4).

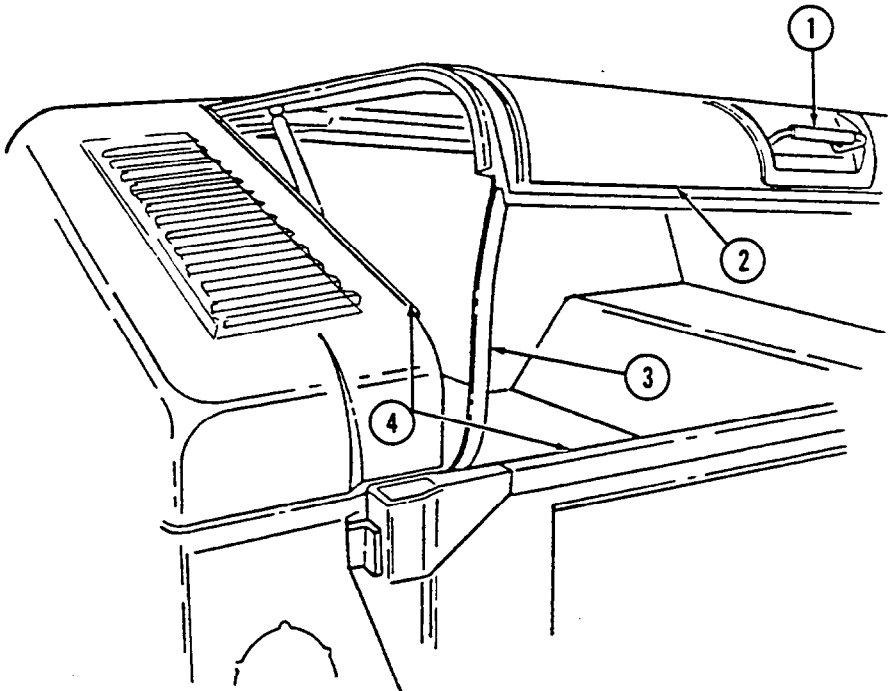

2-33. UP-ARMORED WEAPON STATION OPERATION (M1114)

a. Operation.

WARNING

Use care when opening and closing covers. Do not rest fingers in cover opening. Personnel injury may result.

(1) Open turret weapon station cover (1) by releasing three latches (5) on inside of vehicle (4).

(2) Push small section of cover (2) up and back until resting on large section of cover (1).

(3) Push up large section of cover (1). While holding cover (1), release two rods (3) from cover (1) and insert rods (3) into catch blocks (11).

(4) Slip pins at end of rods (3) into holes in catch blocks (11), then depress and rotate levers (10) until engaged.

NOTE

It may be necessary to rotate turret to set brake.

(5) Disengage turret brake (6) by lifting turret brake handle (7).

(6) Rotate turret (9) to desired position.

(7) Set turret brake (6) by applying downward pressure to turret brake handle (7) until locked.

CAUTION

Do not sit, stand, or place heavy objects on weapon station, tray, or cover. Components may bend and damage to equipment will occur.

(8) Use gunner's sling (8) as seat rest or restraint if gunner is positioned in the weapon station during travel or weapon operation.

b. After Operation.

(1) Depress and rotate levers (10) and remove two rods (3) from catch blocks (11).

(2) Insert rods (3) in cover (1).

(3) Close weapon station cover (1) and secure with three latches (5).

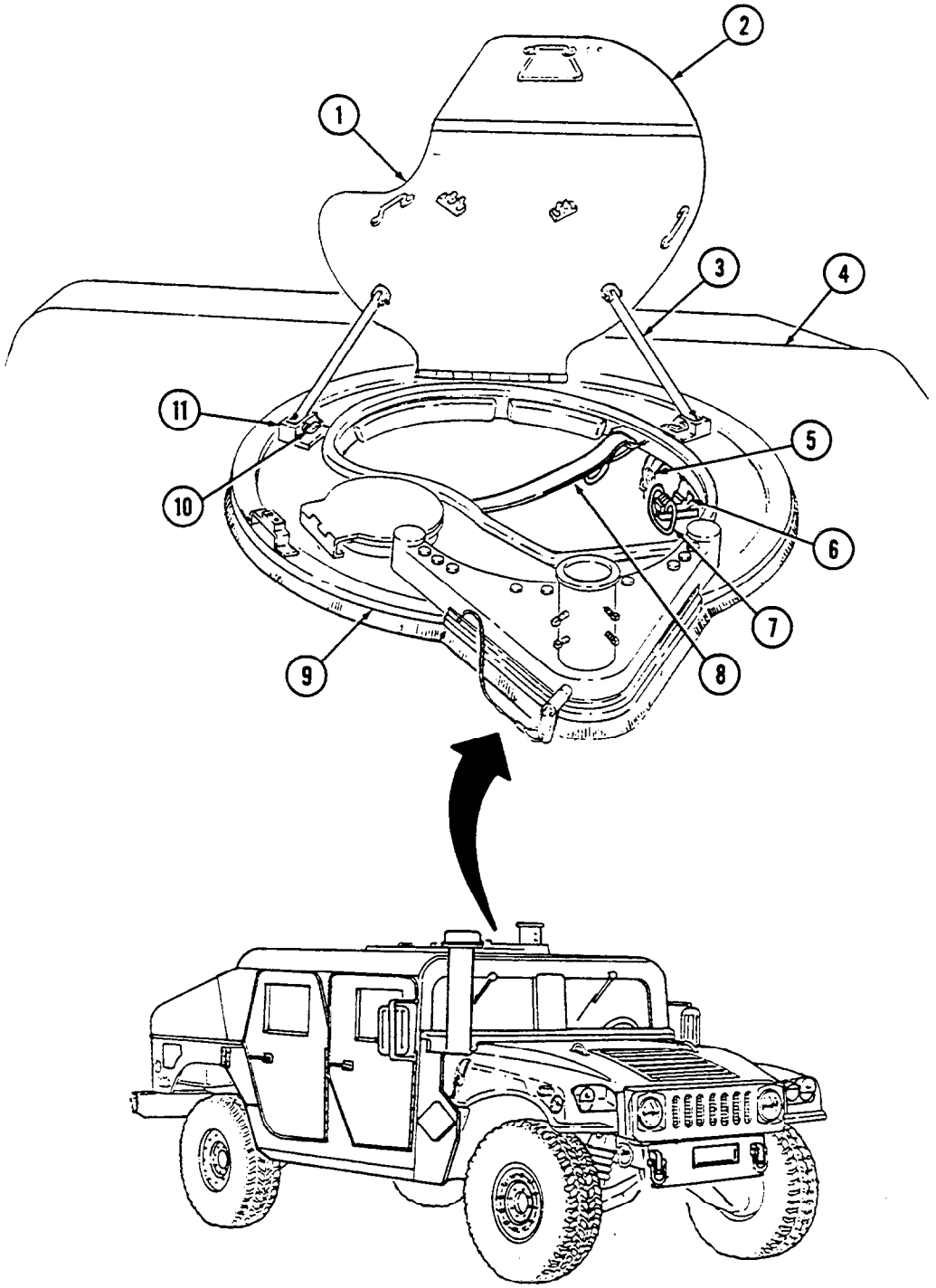

2-34. FUEL DOOR OPERATION (M1114)

a. Operation.

- (1) Open right rear crew door (1).
- (2) Release catch (2) holding fuel door (3) closed.
- (3) Pull fuel door (3) open.

b. After Operation.

- (1) Close fuel door (3).
- (2) Engage catch (2) into fuel door (3) and lock catch (2).
- (3) Close right rear crew door (1).

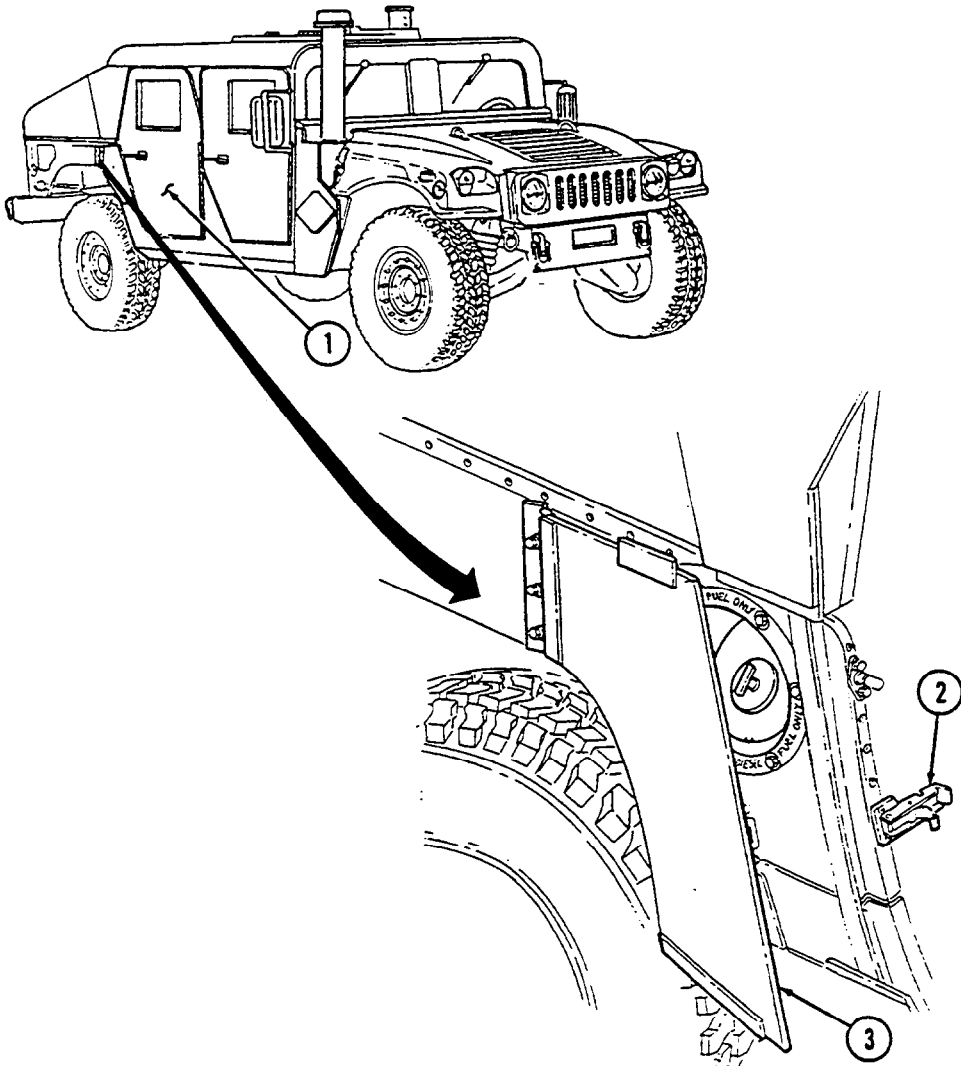

2-35. AIR CONDITIONER OPERATION (M1114)

a. Operation.

- (1) Start engine (para. 2-12).
- (2) Flip air conditioner ON/OFF switch (2) to the right to turn on air conditioner.
- (3) Flip heater fan switch (6) up to turn on.
- (4) Pull fresh air control knob (4) out and slide defroster register (7) to the right to open vents (1).
- (5) Push up floor outlet lever (3) to open floor vents.
- (6) Position fan control knob (5) to desired setting.
- (7) Adjust vents (1) for air flow directions.

b. After Operation.

- (1) Push down floor outlet lever (3) to close floor vents.
- (2) Slide defroster register (7) left and push knob (4) in to close vents (1).
- (3) Flip heater fan switch (6) down to turn off.
- (4) Flip air conditioner ON/OFF switch (2) to the left to turn off air conditioner.
- (5) Stop engine (para. 2-14).

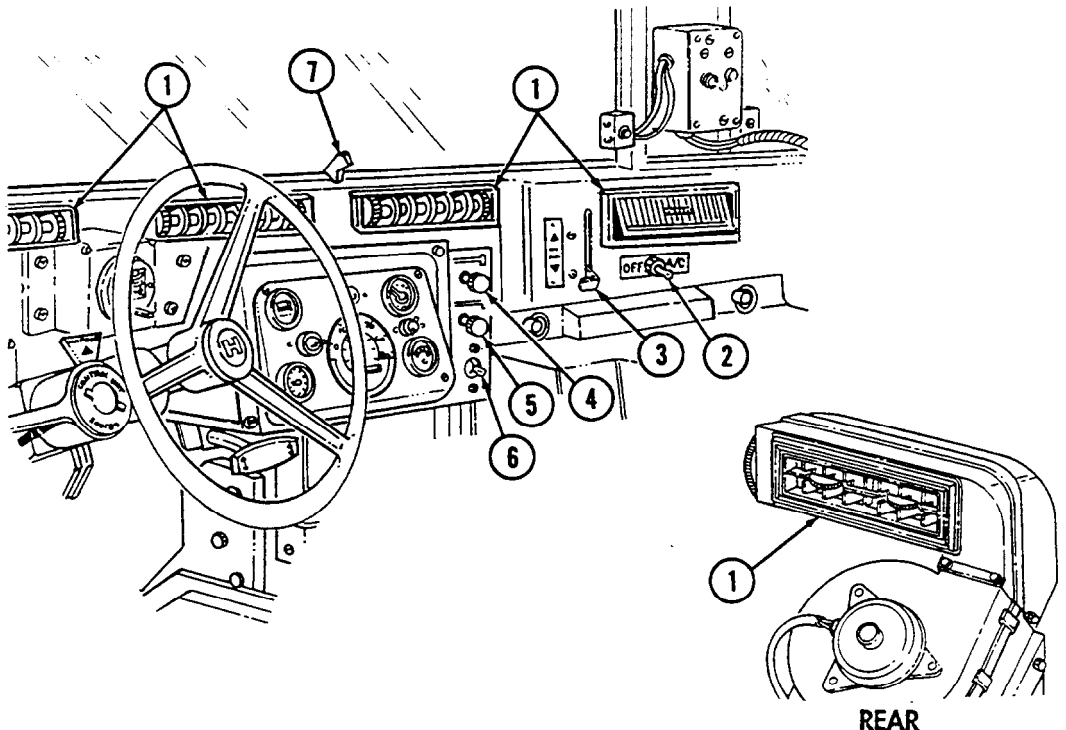

2-36. WINDSHIELD DE-ICER OPERATION (M1114)

NOTE

De-icer will not operate if vehicle is not running.

- a. Start engine (para. 2-12).
- b. Flip toggle switch (1) on de-icer unit (2) to engage position. Hold until indicator light (3) illuminates, then release.

NOTE

De-icer will continue to operate until toggle switch is moved to OFF position or engine is turned off.

- c. Toggle switch (1) will revert to ON position and the de-icer unit (2) will be in operation.
- d. To discontinue de-icer unit (2), flip toggle switch (1) to OFF position, heating element will disengage and indicator light will go out.
- e. Stop engine (para. 2-14).

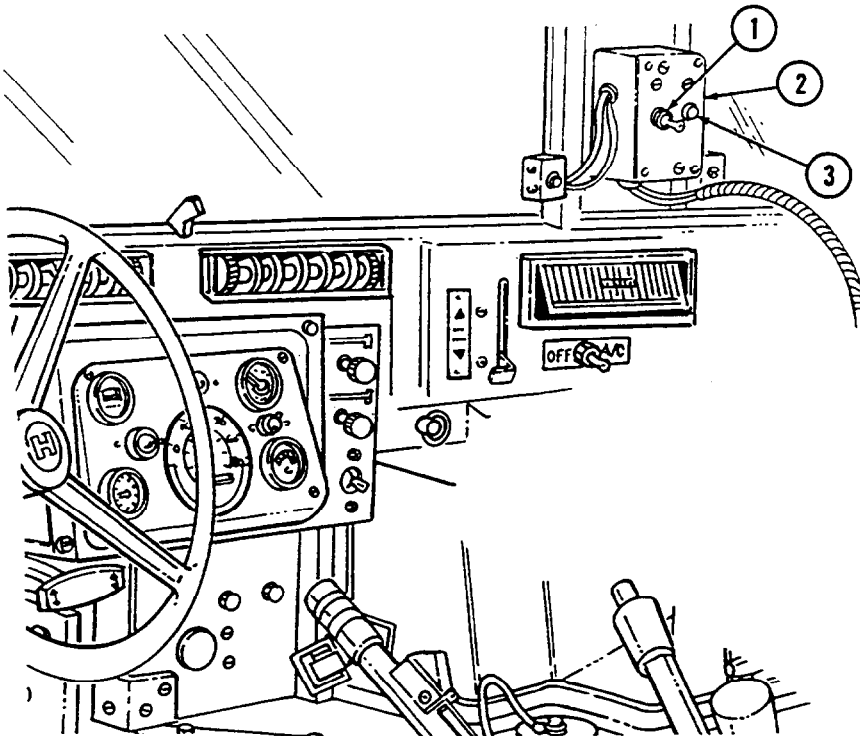

Section IV. OPERATION UNDER UNUSUAL CONDITIONS

2-37. GENERAL

Special instructions for operating and maintaining vehicles under unusual conditions are included in this section. Unusual conditions are extreme temperatures, humidity, and/or terrain. Special care in cleaning and lubrication must be taken in order to keep vehicles operational when operating under unusual conditions.

2-38. OPERATION UNDER USUAL CONDITIONS REFERENCE INDEX

REF. PARA.	TITLE	PAGE NO.
2-39.	Special Instructions	2-104
2-40.	Operating on Unusual Terrain	2-105
2-41.	Cold Weather Starting Below +32°F (0°C)	2-106
2-42.	Operating in Extreme Cold, on Ice or Snow	2-107
2-43.	Operating in Dusty, Sandy Areas	2-108
2-44.	Operating in Mud	2-109
2-45.	Operating in Extreme Heat	2-111
2-46.	Operating in Rainy or Humid Conditions	2-112
2-47.	Shallow Water Fording Operation	2-112
2-48.	Deep Water Fording (M1113) Operation	2-114
2-49.	Runflat Operation	2-121
2-50.	Vehicular Heater Operation	2-122

2-39. SPECIAL INSTRUCTIONS

WARNING

This vehicle has been designed to operate safely and efficiently within the limits specified in this TM. Operation beyond these limits is prohibited by IAW AR 70-1 without written approval from the Commander, U.S. Army Tank-automotive and Armaments Command, ATTN: AMSTA-CM-S, Warren, MI 48397-5000.

NOTE

Except where noted, all normal operating procedures will apply in addition to special instructions for unusual operating conditions.

- a. **Cleaning.** Refer to para. 2-5 for cleaning instructions and precautions.
- b. **Lubrication.** Refer to appendix G for proper lubricating instructions.
- c. **Driving Instructions.**

(1) FM 21-305, Manual for the Wheeled Vehicle Driver, contains special driving instructions for operating wheeled vehicles.

(2) FM 55-30, Army Motor Transport Units and Operations, contains instructions on driver selection, training, and supervision.

(3) FM 9-207, Operation and Maintenance of Ordnance Materiel in Cold Weather, contains instructions on vehicle operation in extreme cold of 0° to -65°F (-18° to -54°C).

(4) Other documents with information on vehicle operation under unusual conditions are:

(a) FM 31-70 Basic Cold Weather Manual (d) FM 90-5 Jungle Operations

(b) FM 31-71 Northern Operations (e) FM 90-6 Mountain Operations

(c) FM 90-3 Desert Operations

d. **Special Purpose Kits.** Paragraphs describing special purpose kits for operation under unusual conditions are:

(1) Deep water fording operation, para. 2-48.

(2) Vehicular heater operation, para. 2-50.

e. **Transmission Range Selection.** For proper transmission range selection, refer to table 1-6. If transmission range selection is peculiar to an unusual operating condition, it will be specified in the applicable paragraph.

f. **Transfer Case Range Selection.**

CAUTION

- Vehicle must be stopped and transmission shift lever in N (neutral) before transfer case can be shifted. Failure to do this will result in damage to drivetrain.
- Damage to drivetrain will result if transfer case is operated in L (low range) or H/L (high/lock range) on high-traction surfaces with no wheel slippage.

CAUTION

- When necessary to temporarily operate transfer case in H/L (high/lock range) or L (low range) when additional traction is needed to prevent wheel slippage, avoid sharp, continuous turns. Failure to avoid sharp, continuous turns while operating transfer case in locked ranges may cause damage to drivetrain.
- Immediately after operation in H/L (high/lock range) or L (low range), ensure transfer case is shifted to H (high range) to avoid damage to drivetrain. If any noises from drivetrain components are heard, ensure that transfer case range is properly selected.

For proper transfer case range selection, refer to table 1-7. If transfer case range selection is peculiar to an unusual operating condition, it will be specified in the applicable paragraph.

2-40. OPERATING ON UNUSUAL TERRAIN

a. General Rules. Driving off-road over rough or unusual terrain basically requires using good driving sense. Experience is the best teacher, but there are a few good rules to keep in mind when you are in that kind of driving situation.

WARNING

- Use extreme caution when transporting personnel. Rollover protection is available for the crew area only and is not provided in the troop/cargo area. Although certain design characteristics of the vehicle, such as vehicle width, ground clearance, independent suspension, etc., provide improved capabilities, accidents can still happen.
- Operators are reminded to observe basic safe driving techniques/skills when operating the vehicle, especially when transporting personnel. Vehicle speed must be reduced consistent with weather and road/terrain conditions. Obstacles such as stumps and boulders must be avoided. Failure to use basic safe driving techniques/skills may result in injury or death to personnel and damage to equipment.

(1) Use H/L (high/lock range) or L (low range) only when absolutely required by the conditions identified in table 1-7. After operations on unusual terrain, be sure to shift the transfer case from H/L (high/lock range) or L (low range) to H (high range) to avoid damaging drivetrain components.

(2) Select proper transmission and transfer case driving ranges. Refer to table 1-6 for transmission range selections. For transfer case range selections, refer to table 1-7.

(3) Keep engine at a moderate speed. The engine works at its best pace in mid-range revolutions per minute (rpm). You can slow down or speed up quickly without changing gears if you get into a tight spot. Use transmission shift lever and transfer case shift lever to control engine speed.

(4) Attempt to keep wheels from spinning. If wheels start to spin, ease off the accelerator pedal until wheels regain traction.

(5) Instructions for placing vehicle in motion (para. 2-13) also apply to operating on unusual terrain.

2-40. OPERATING ON UNUSUAL TERRAIN (Cont'd)

b. Unusual Terrain Driving Techniques.

CAUTION

- Do not shift into any lower gear than is necessary to maintain headway. Attempt to maintain a constant engine speed. Over-revving engine will cause the wheels to slip, and traction will be lost.
- Before ascending or descending steep hills, stop vehicle, place transmission to N (neutral), and shift transfer case to L (low range). Failure to shift transfer case to L (low range) before ascending or descending steep hills may result in damage to drivetrain.

(1) Before climbing a steep hill, shift the transfer case into L (low range) and the automatic transmission into 1 (first). If wheels start to slip, walk the vehicle the last few remaining feet of a hill by swinging the front wheels sharply left and right if situation permits. This action will provide fresh "bite" into the surface and will usually result in enough traction to complete the climb.

CAUTION

When L (low range) is used for engine braking while descending steep grades, avoid sharp, continuous turns. Failure to avoid sharp, continuous turns while operating transfer case in range may cause damage to drivetrain.

(2) You can proceed safely down a steep grade by shifting the transfer case into L (low range) and the transmission into 2 (second) or 1 (first). Let the vehicle go slowly down the hill with all four wheels turning against engine compression.

WARNING

Do not travel diagonally across a hill unless it is absolutely necessary, or injury to personnel or damage to equipment may result.

(3) When moving across a slope, choose the least angle possible, keep moving, and avoid turning quickly.

(4) If it is difficult to shift out of a locked range, drivetrain torque buildup may have occurred. If necessary to relieve drivetrain torque buildup when leaving a low traction surface for a high traction surface, the vehicle should be backed up for a distance of approximately 5 ft (1.5 m) before proceeding.

2-41. COLD WEATHER STARTING BELOW +32°F (0°C)

WARNING

Starting aids will not be used on the engine. Use of starting aids may cause damage to vehicle and injury or death to personnel.

a. Start engine (para. 2-12).

WARNING

- Do not use the hand throttle as an automatic speed or cruise control. The hand throttle does not automatically disengage when brake is applied, resulting in increased stopping distances and possible hazardous and unsafe operation.
- Do not fully apply hand throttle when engine is not under load.

NOTE

If engine cranks slowly and voltmeter indicates low battery charge level, attempt to slave start vehicle (para. 2-23). If vehicle still will not start, perform troubleshooting procedures in table 3-1.

b. After engine starts, pull out hand throttle until desired engine speed is obtained. Twist handle to lock hand throttle.

c. Allow engine to warm up at an increased speed for approximately three minutes.

d. After warm-up period, unlock and push in hand throttle. Allow engine speed to decrease.

2-42. OPERATING IN EXTREME COLD, ON ICE OR SNOW

a. Before Operation.

(1) Operate vehicular winterization equipment (para. 2-50).

(2) Scrape off any ice accumulated on vehicle.

(3) Remove ice and snow from area around air cleaner intake cap.

(4) Refer to para. 2-41 for cold weather starting instructions.

(5) Refer to para. 2-40 for techniques that can be used when operating on unusual terrain.

(6) Refer to para. 3-22 for tire chain installation and operation.

b. During Operation.

WARNING

- Vehicle operation in snow is a hazardous condition. Operator must travel at reduced speeds and be prepared to meet sudden changes in road conditions. Failure to maintain safe stopping distances may cause damage to vehicle and injury or death to personnel.
- Pump brakes gradually when stopping vehicle on ice or snow. Sudden braking will cause wheels to lock and vehicle to slide out of control, causing damage to vehicle and injury or death to personnel.
- Chock blocks shall be used when parking a vehicle in extreme cold conditions. Failure to do so may result in injury to personnel or damage to equipment.

NOTE

Keep area around air cleaner intake cap clear of snow and ice. Snow and ice may melt, refreeze, and cause restriction in air intake system. If necessary, remove intake cap and clear ice and snow without damaging intake cap screen. Hold the cap near the vehicle exhaust to quickly melt ice without damaging screen.

(1) Place transmission shift lever in **(D)** (overdrive), and transfer case shift lever in H/L (high/lock range). Place vehicle in motion slowly to prevent wheels from spinning.

NOTE

If additional power is needed to extract vehicle when mired in snow, place transmission in 1 (first) and transfer case in L (low range). After vehicle is extracted from mired condition, immediately return transfer case to H/L (high/lock range) position and transmission to **(D)** (overdrive).

(2) If rear skidding occurs:

(a) Let up on accelerator pedal.

(b) Turn steering wheel in direction of skid until control has been regained.

(c) Apply brake pedal in a gradual pumping manner.

c. After Operation.

(1) Remove all ice and snow from underside of vehicle and fuel tank filler cap.

(2) Drain fuel filter (para. 3-11).

2-43. OPERATING IN DUSTY, SANDY AREAS

a. **General.** Vehicles operating in dusty or sandy areas require frequent servicing of the air filter and cooling system.

NOTE

For dusty conditions, a air cleaner, NSN 2940-01-302-8028, can be inserted in the air intake shield assembly at the discretion of the unit commander.

b. Before Operation.

(1) When operating on loose sand or soft ground, place transfer case shift lever in H/L (high/lock range) position and transmission shift lever in **(D)** (overdrive).

(2) Refer to para. 2-40 for techniques that can be used when operating on unusual terrain.

c. During Operation.

NOTE

If additional power is needed to extract vehicle when mired in sand, place transmission in 1 (first) and transfer case in L (low range). After vehicle is extracted from mired condition, immediately return transfer case to H/L (high/lock range) position and transmission to **(D)** (overdrive).

(1) Frequently check air restriction gauge. If indicator shows red, park vehicle, stop engine, and refer to para. 3-15 for emergency air cleaner servicing.

(2) If engine overheating occurs:

(a) Park vehicle, and allow engine to idle.

(b) Observe coolant temperature gauge for steady cooling.

CAUTION

Stop engine if coolant temperature gauge suddenly increases beyond approximately 230°F (110°C). Failure to comply will result in damage to engine.

(c) If coolant temperature continues to increase or does not lower, stop engine. Perform applicable troubleshooting procedures in table 3-1.

(3) Accelerate slowly so wheels will not spin and dig into sand.

CAUTION

Use a wrecker or second vehicle equipped with winch to recover vehicles mired in deep sand. Do not attempt to rock vehicles out of deep sand with quick transmission shift changes. Damage to transmission will occur.

d. After Operation.

(1) At end of daily operation, clean all sand from accelerator linkage and brake components.

(2) Park vehicle in shade whenever possible to protect tires, soft tops, paint, wood, and seals from sun, dust, and sand.

(3) If shade is not available, cover vehicle with tarpaulin. When entire vehicle cannot be covered, protect windows and hood with tarpaulin to prevent entry of sand or dust.

(4) Vehicles completing operation in dusty, sandy areas must be lubricated and serviced by unit maintenance as soon as possible.

2-44. OPERATING IN MUD

a. Before Operation.

(1) Before operating in mud, place transfer case shift lever in H/L (high/lock range) and transmission shift lever in **(D)** (overdrive).

(2) Refer to para. 2-40 for techniques that can be used when operating on unusual terrain.

b. During Operation.

CAUTION

- Do not repeatedly shift transmission or overspeed the engine during operation in deep mud. Damage to drivetrain may result.
- Use wrecker or a second vehicle equipped with winch to recover vehicles mired in deep mud. Do not attempt to rock vehicles out of deep mud with quick transmission shift changes. Damage to transmission will occur.

NOTE

If additional power is needed to extract vehicle when mired in mud, place transmission in 1 (first) and transfer case in L (low range). After vehicle is extracted from mired condition, immediately return transfer case to H/L (high/lock range) position and transmission to **(D)** (overdrive).

Skidding and sudden loss of steering control are operating problems in mud. When rear end skidding occurs, immediately turn wheel in direction of skid until control has been regained.

c. After Operation.

WARNING

Do not rely on service brakes until they dry out. Keep applying brakes until uneven braking ceases. Failure to do this may cause damage to vehicle and injury or death to personnel.

CAUTION

Do not allow water to enter air intake cap or air cleaner assembly. Damage to engine will occur.

- (1) Wash the following components as soon as possible with low-pressure water:
- (a) Radiator and oil cooler
 - (b) Propeller shaft U-joint and halfshafts
 - (c) Steering linkage and ball joints
 - (d) Brake rotors and pads (service)
 - (e) Parking brake linkage
 - (f) Service lights
 - (g) Transmission control linkage
 - (h) Accelerator control linkage
 - (i) Swaybar bushings
 - (j) Towing pintle
 - (k) Fuel filler cap
 - (l) Vehicle exterior
 - (m) Geared hubs

2-44. OPERATING IN MUD (Cont'd)

- (2) Remove mud from air cleaner dump valve (para. 3-16).
- (3) Remove mud from drain hole (1) on converter housing cover (2).
- (4) Remove mud from battery box drain holes.

NOTE

To prevent parking brake linkage from binding, lithium grease should be used after operating in mud.

- (5) Clean mud, grit, and debris from linkage. Apply lithium grease (appendix D, item 14), and move linkage back and forth to work into joints.
- (6) After operation in deep mud, vehicle must be lubricated and serviced by unit maintenance as soon as possible.

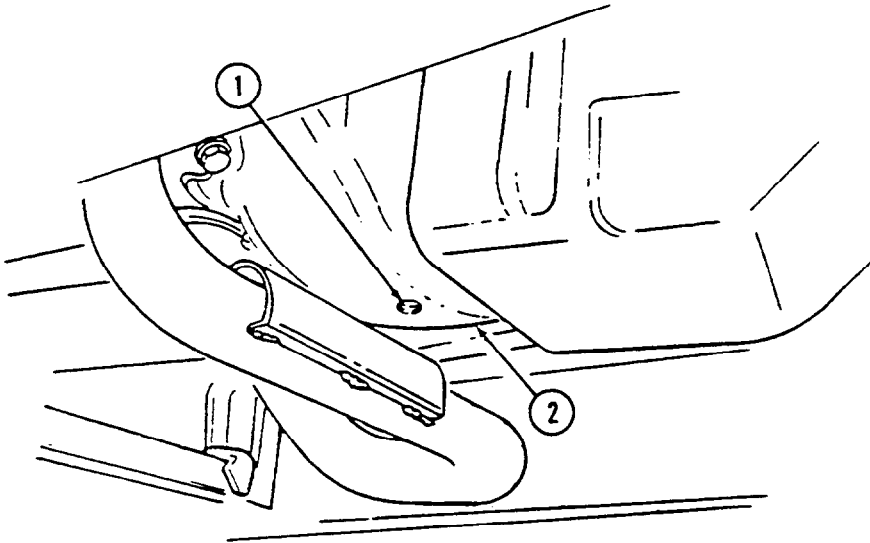

2-45. OPERATING IN EXTREME HEAT

a. General. Extreme heat exists when ambient temperatures reach 95°F (35°C) or more. The effect of extreme heat on vehicle engine is a decrease in engine efficiency.

b. Before Operation.

- (1) Perform before operation checks and services in table 2-2.
- (2) Check for foreign objects in front of radiator and clean as required.
- (3) Check batteries more frequently. If electrolyte is low, add distilled water (appendix D, item 7).

c. During Operation.

CAUTION

Avoid continuous vehicle operation at high speeds. Avoid long, hard pulls on steep grades with transfer case shift lever in L (low range) position. Damage to transfer case will result.

(1) Frequently check coolant temperature gauge (2) and oil pressure gauge (1). Engine is overheating if one or more of the following conditions exist:

(a) Engine coolant temperature is more than approximately 230°F (110°C) as indicated by temperature gauge (2).

(b) Engine oil pressure drops below approximately 15 psi (103 kPa) with engine under a load.

(c) Engine oil pressure drops below approximately 6 psi (41 kPa) with engine at idle.

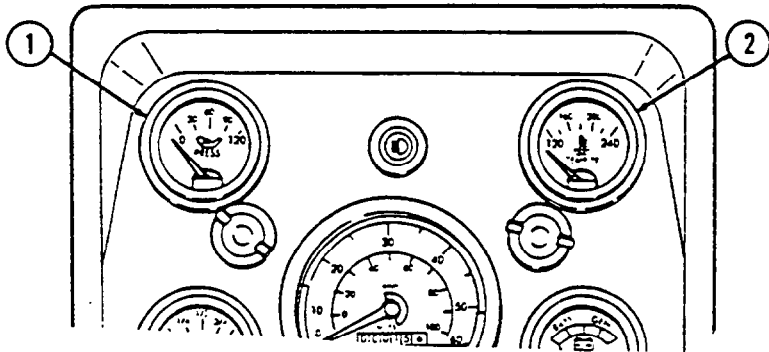

(2) If engine overheating occurs:

- (a) Park vehicle, allowing engine to idle.
- (b) Observe coolant temperature gauge (2) for steady cooling.

CAUTION

Stop engine if coolant temperature gauge suddenly increases beyond approximately 230°F (110°C). Failure to comply will result in damage to engine.

(c) If engine coolant temperature continues to increase or does not lower, stop engine. Perform troubleshooting procedures in table 3-1.

2-46. OPERATING IN RAINY OR HUMID CONDITIONS

a. General. Materiel inactive for long periods during rainy or humid conditions can rust rapidly. Fungus may develop in the fuel tanks as well as on soft tops, seats, and other components. Frequent inspections, cleaning, and lubrication are necessary to maintain the operational readiness of vehicles.

b. Before Operation. Fuel filter must be drained frequently because of high condensation in fuel system. To drain fuel filter, refer to para. 3-11.

c. During Operation.

(1) If necessary, place transfer case shift lever in H/L (high/lock range) to start without spinning wheels.

(2) Do not spin wheels when placing vehicle in motion in heavy rain.

(3) Refer to para. 2-40 for techniques that can be used when operating on unusual terrain.

2-47. SHALLOW WATER FORDING OPERATION

a. General. The vehicles have a 30 in. (76 cm) shallow water fording capability.

CAUTION

Never attempt shallow water fording unless water depth is known to be 30 in. (76 cm) or less, and bottom is known to be hard. Do not exceed 5 mph (8 kph) during fording operation. Damage to vehicle may result.

b. Before Operation.

(1) Ensure oil dipstick, transmission dipstick, oil filler cap, and fuel tank cap are secure.

(2) Secure all loose objects on vehicle.

(3) Ensure battery caps are all present and tight.

(4) Place transfer case shift lever in H (high range).

c. During Operation.

(1) Enter water slowly and maintain even vehicle speed while fording.

(2) Exit water in area with gentle slope.

NOTE

- Hydrostatic lock is caused by the entry of substantial amounts of water into the engine through the air intake system and subsequent contamination of the fuel system. Hydrostatic lock most frequently occurs during or just after fording. Water is forced into the air intake system, drawn into the engine, and locks up the engine.
- Notify unit maintenance if you suspect hydrostatic lock and they will test the engine.

d. After Operation.**WARNING**

Do not rely on service brakes after fording until the brakes dry out. Keep applying brakes until uneven braking ceases. Failure to do this may cause damage to vehicle or injury or death to personnel.

NOTE

If accumulated water drains slowly through floor drain holes, refer to unit maintenance for drilling and improving drain holes.

- (1) If fording operation was through salt water, wash and wipe off salt deposits as soon as possible.

NOTE

To prevent parking brake linkage from binding, lithium grease should be used after operating in water.

- (2) Clean mud, grit, and debris from brake linkage. Apply lithium grease (appendix D, item 14), and move linkage back and forth to work into joints.

- (3) After shallow water fording operation, vehicle must be lubricated and serviced by unit maintenance as soon as possible.

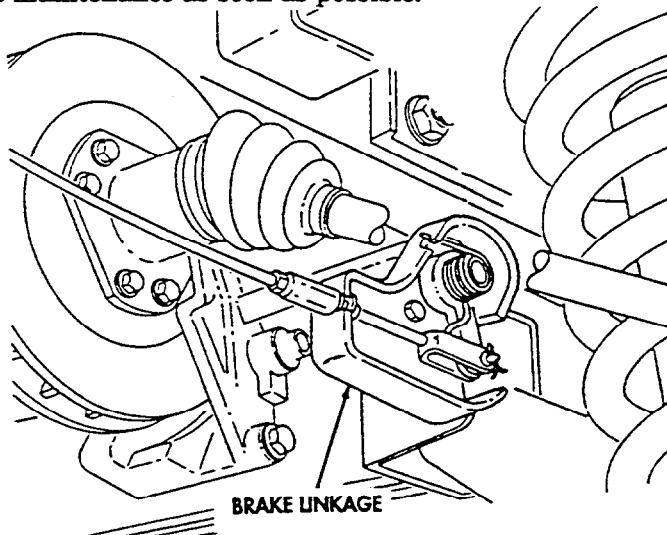

2-48. DEEP WATER FORDING (M1113) OPERATION

a. **General.** The deep water fording kit allows M1113 vehicles to ford water up to 60 in. (152 cm) deep.

CAUTION

Never attempt deep water fording unless water depth is known to be 60 in. (152 cm) or less, and bottom is known to be hard. Do not exceed 5 mph (8 kph) during fording operation. Damage to vehicle may result.

b. Before Operation.

- (1) Raise and secure hood (para. 3-9).
- (2) Ensure rubber cap (2) on bottom of air cleaner body (1) is secure.
- (3) Lower and secure hood (para. 3-9).

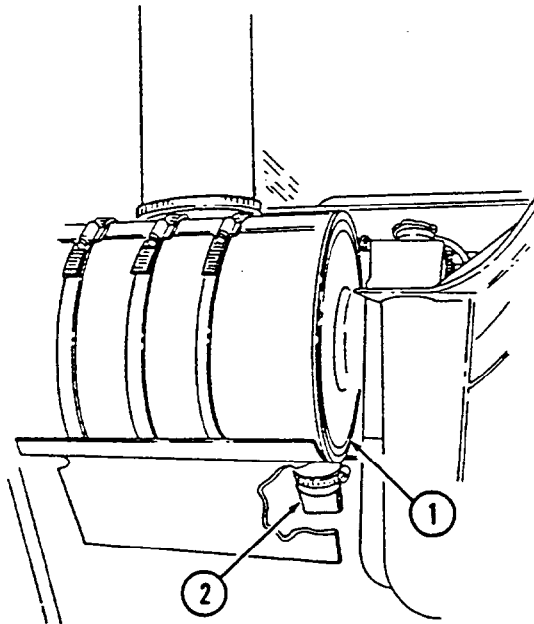

WARNING

Exhaust system components are hot after prolonged vehicle use. Ensure exhaust system components are cool before removing/ installing exhaust assembly. Failure to do this may result in injury to personnel.

NOTE

Any items removed for fording must be stowed for reuse.

(4) Remove three locknuts (19), washers (11), capscrews (12), and washers (11) securing tailpipe (13) to muffler (18).

(5) Remove two nuts (17), lockwashers (16), and U-bolt (14) securing tailpipe (13) to clamp (15).

(6) Remove tailpipe (13) and gasket (10) from muffler (18).

(7) Install two rubber isolators (7) into wheelhouse (8). To ease installation, wet rubber isolators (7) with water.

(8) If isolators (7) cannot be installed easily, check alignment of holes in wheelhouse (8) and reinforcement bracket (5). To align holes, loosen capscrews (6) securing reinforcement bracket (5) to wheelhouse (8). Align holes in wheelhouse (8) and reinforcement bracket (5) and tighten capscrews (6). Install isolators (7).

(9) Install exhaust assembly (9) and gasket (10) on muffler (18) with three washers (11), capscrews (12), washers (11), and locknuts (19).

(10) Install exhaust assembly (9) on wheelhouse (8) with two washers (4) and locknuts (3).

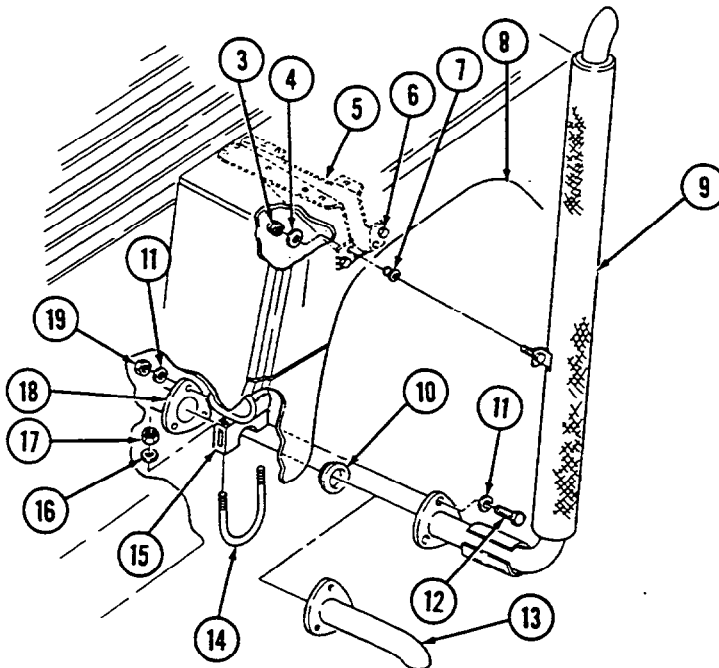

2-48. DEEP WATER FORDING (M1113) OPERATION (Cont'd)

(11) Ensure oil dipstick, transmission dipstick, oil filler cap, and fuel tank cap are secure.

(12) Secure all loose objects on vehicle.

(13) Ensure battery caps are all present and tight.

(14) Place transfer case shift lever in appropriate range (table 1-7).

(15) Turn off all non-essential electrical loads (lights, fan, heater/defroster).

(16) Place fording selector switch (1) in DEEP FORD position prior to entering water.

(17) Pull out hand throttle (2) until desired engine speed is obtained. Twist hand throttle (2) to lock in position.

(18) Open driver and passenger windows.

c. During Operation.

(1) Enter water slowly and maintain even vehicle speed, 5 mph (8 kph) maximum.

(2) Exit water in area with gentle slope.

(3) Place fording selector switch (1) in VENT position after leaving water.

WARNING

After fording, do not use the hand throttle as an automatic speed or cruise control. The hand throttle does not automatically disengage when brake is applied, resulting in increased stopping distances and possible hazardous and unsafe operation. Injury to personnel or damage to equipment may result.

(4) Unlock and push in hand throttle (2).

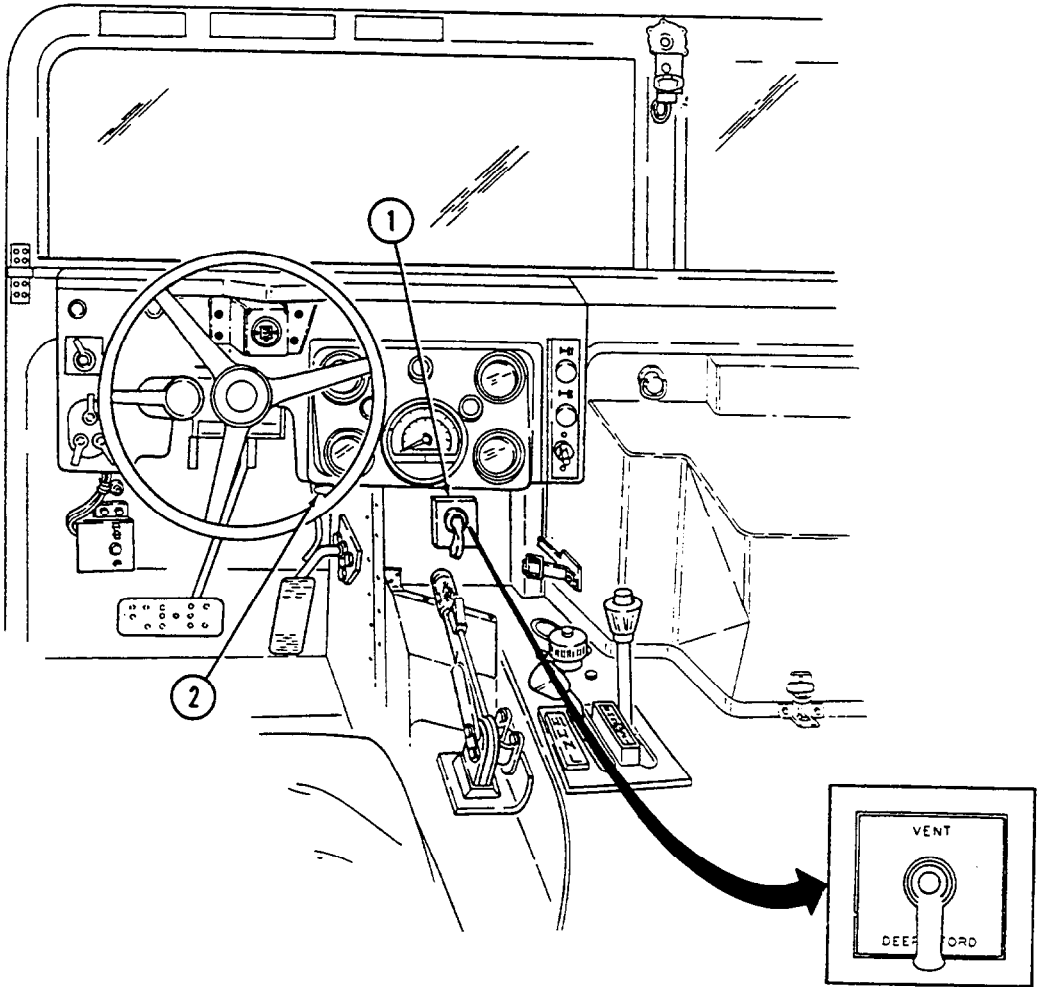

2-48. DEEP WATER FORDING (M1113) OPERATION (Cont'd)

WARNING

Do not rely on service brakes after fording until the brakes dry out. Keep applying brakes until uneven braking ceases. Failure to do this may cause damage to vehicle, and injury or death to personnel.

- (5) Place transfer case shift lever in desired range (table 1-7).

NOTE

- Hydrostatic lock is caused by the entry of substantial amounts of water into the engine through the air intake system and subsequent contamination of the fuel system. Hydrostatic lock most frequently occurs during or just after fording. Water is forced into the air intake system, drawn into the engine, and locks up the engine.
- Notify unit maintenance if you suspect hydrostatic lock and they will test the engine.

d. After Operation.

- (1) Stop engine.

WARNING

Exhaust system components are hot after prolonged vehicle use. Ensure exhaust system components are cool before removing/ installing exhaust assembly. Failure to do this may result in injury to personnel.

NOTE

- Steps 2 through 10 are performed only if required.
 - If accumulated water drains slowly through the holes, refer to unit maintenance for drilling and improving drain holes.
- (2) Remove three locknuts (2), washers (8), capscrews (9), washers (8), gasket (7), and exhaust assembly (6) from muffler (1).
 - (3) Remove two locknuts (3), washers (4), and exhaust assembly (6) from wheelhouse (5).
 - (4) Install gasket (7) and tailpipe (10) on muffler (1) with three washers (8), capscrews (9), washers (8), and locknuts (2).
 - (5) Install tailpipe (10) on clamp (12) with U-bolt (11), two lockwashers (13), and nuts (14).

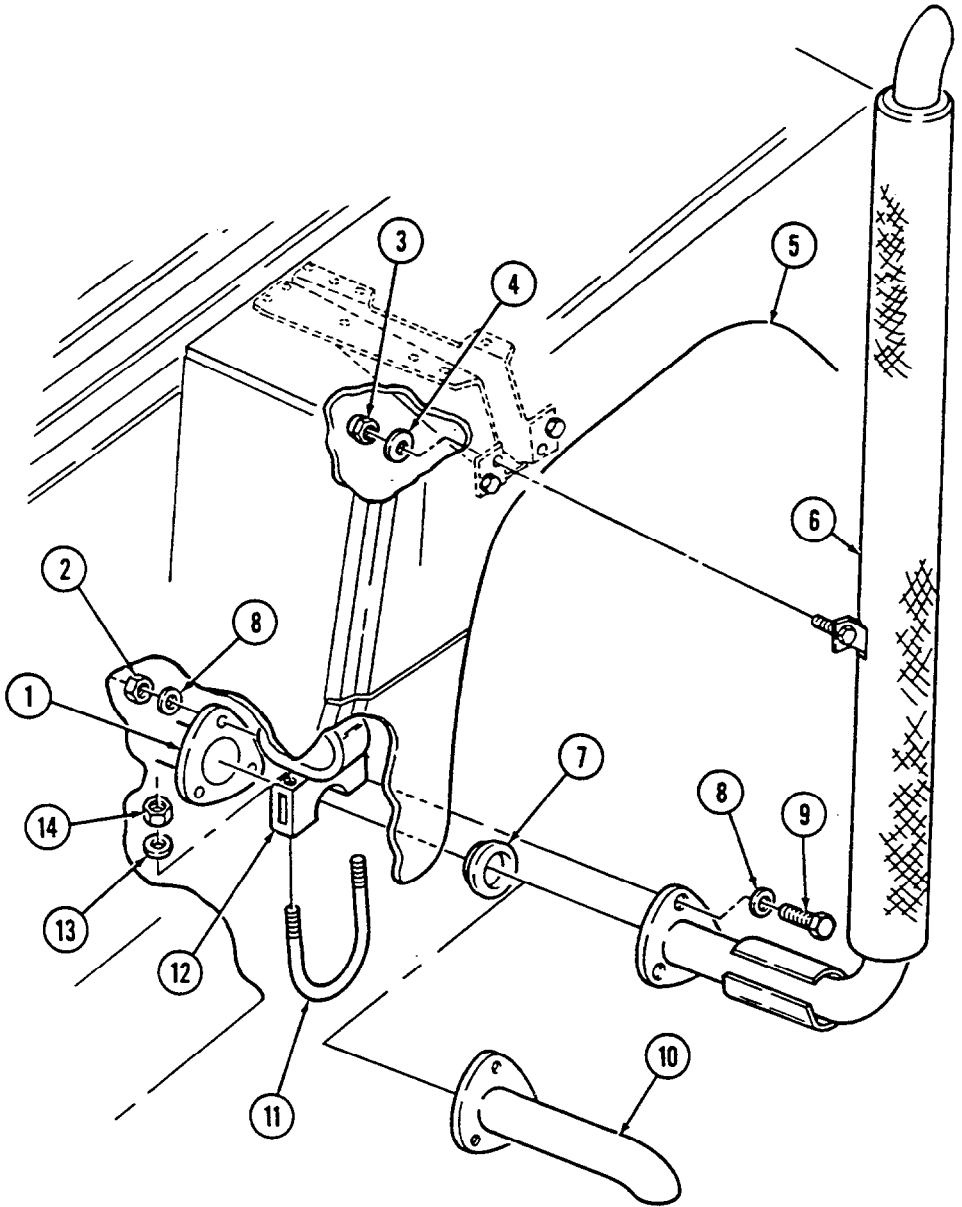

2-48. DEEP WATER FORDING (M1113) OPERATION (Cont'd)

(6) Clean and stow intake and exhaust assembly components.

(7) If fording operation was through salt water, wash and wipe off all salt deposits as soon as possible.

NOTE

To prevent parking brake linkage from binding, lithium grease should be used after operating in water.

(8) Clean mud, grit, and debris from brake linkage. Apply lithium grease (appendix D, item 14), and move linkage back and forth to work into joints.

(9) After deep water fording operation, vehicle must be lubricated and serviced by unit maintenance as soon as possible.

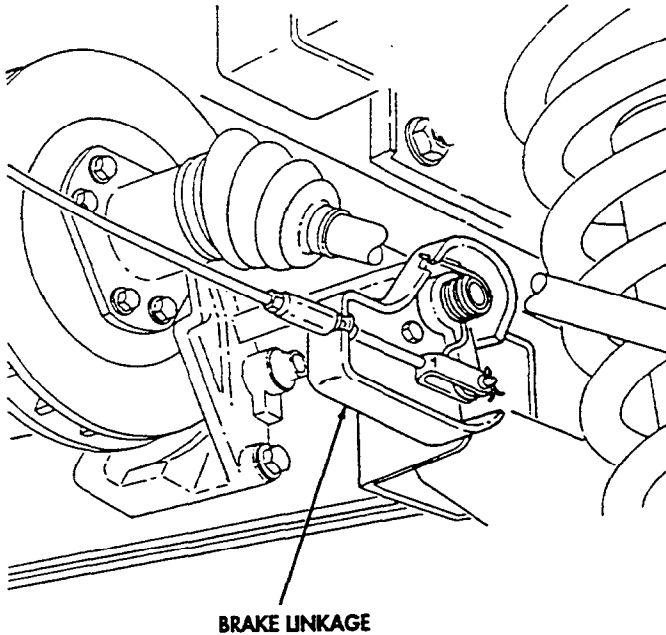

2-49. RUNFLAT OPERATION

The vehicles are equipped with runflat devices, allowing the vehicle to be driven with one or more tires flat. For runflat operations, refer to table 2-4.

WARNING

- Do not exceed 30 mph (48 kph) during any runflat operation. Do not exceed 20 mph (32 kph) with both rear tires flat. Loss of vehicle control may occur, causing damage to equipment and injury or death to personnel.
- Speeds indicated in table 2-4 are maximum and must be reduced when traveling on secondary roads, cross-country, or in traffic. Failure to reduce speeds could cause loss of control of vehicle, causing damage to equipment and injury or death to personnel.
- When driving vehicle, existing conditions are constantly changing. Never drive at a speed greater than is reasonable and prudent for these conditions. Loss of vehicle control may occur, causing damage to equipment and injury or death to personnel.

CAUTION

- A wheel that has been run flat must be replaced and inspected by unit maintenance as soon as possible before reuse, or damage to equipment may result.
- Runflat operation may cause the tread to separate from the tire and/or wheel. If abnormal handling is experienced, or noise such as flapping or pounding around the wheel well occurs, the tread needs to be cut away from the wheel before continuing operation. Failure to do so could result in damage to the vehicle.

Table 2-4. Runflat Operation.

NOTE		
Runflat travel distance will improve with rubber runflat. If additional travel is required, tire tread may be cut away from tire.		
Combination of Flat Tires	Recommended Vehicle Speed	Distance
Two tires flat – rear	20 mph max. (32 kph)	30 mi (48 km)
One tire flat – any location	30 mph (48 kph)	30 mi (48 km)
Two tires flat – same side	30 mph (48 kph)	30 mi (48 km)
Two tires flat – front only	30 mph (48 kph)	30 mi (48 km)

2-50. VEHICULAR HEATER OPERATION

NOTE

The vehicular heater is an optional kit which may or may not be installed on the vehicle.

a. General. The vehicular heater is used for pre-heating and boosting the heat of the water-cooled engine. The heater works in conjunction with the heating system of the vehicle to heat driver's cabin, passenger compartment, and to defrost windows and windshield of the vehicle.

The heater operates independently of the vehicle engine. It is connected to the coolant circuit or the heating circuit, fuel supply system, and the electrical system of the vehicle.

When the operating temperature has been reached, the temperature sensor will send a signal to the control unit. The heat output will then be reduced to 25 percent. Should the temperature still remain at the upper limit, the heater will turn off, but the coolant pump will remain running.

The heater will automatically restart once the system temperature has dropped to the lower switch point of the sensor.

WARNING

- Do not operate the vehicular heater in a closed area without proper exhaust evacuations. Damage to heater or injury to personnel may result.
- Do not operate the vehicular heater when refueling. Damage to heater or injury to personnel may result.

NOTE

- After shutting off the on/off switch there is a cool down period of 90 seconds. The blower and coolant pump works for 90 seconds to purge the heater.
- DFA fuel should be used at temperatures below -40°F (-4°C).

b. Operation.

(1) Activate heater by moving on/off rotary switch (1) on the vehicle control panel (2) to ON.

(2) A green light (3) on on/off rotary switch (1) indicates heater is in operation.

(3) If, during heater operation supplied voltage drops below $10.25 \pm 0.5/20.5 \pm 1.0$ V for more than 20 seconds, fault lock out will occur and the heater will switch off. If this happens, notify unit maintenance.

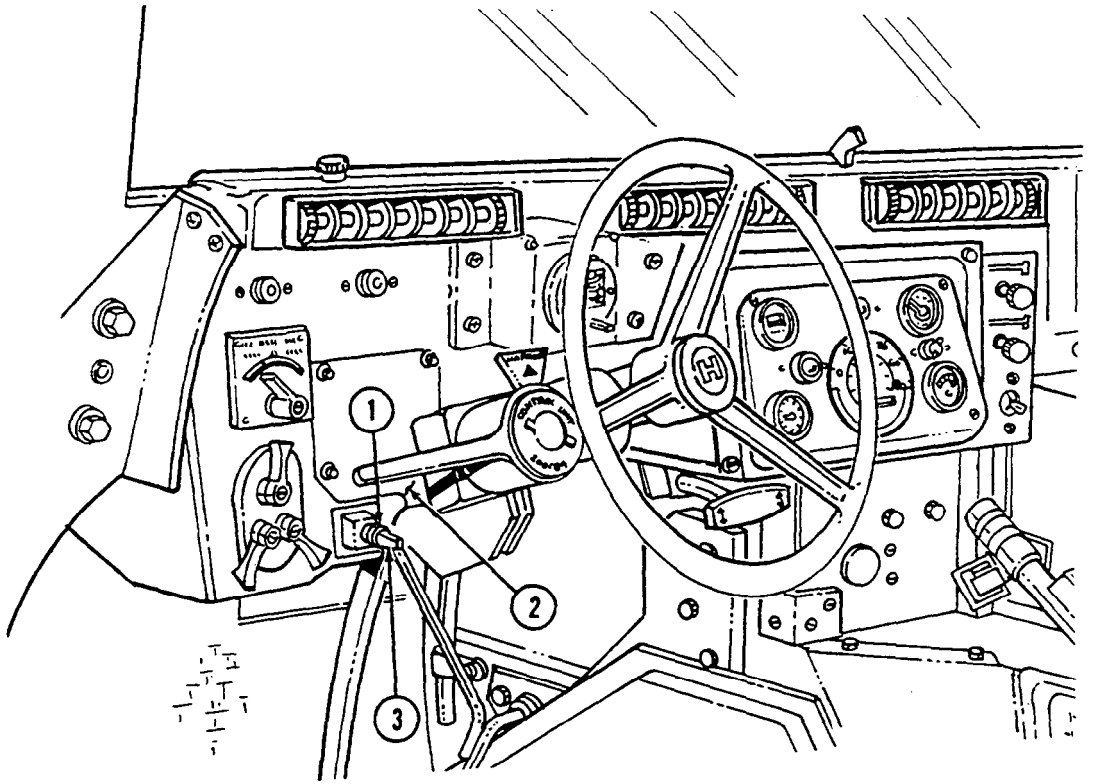

Section V. S250 SHELTER CARRIER OPERATION

2-51. GENERAL

a. This section provides operating instructions for components found on M1113 shelter carriers.

b. Refer to para. 2-2a for stowage location of fire extinguisher on S250 shelter carrier. Refer to para. 2-29 for operation of fire extinguisher.

2-52. S250 SHELTER CARRIER OPERATION REFERENCE INDEX

REF. PARA.	TITLE	PAGE NO.
2-53.	Windshield Assembly Operation	2-124
2-54.	Removal and Installation of Two-Man Crew Area Soft Top Enclosure	2-126
2-55.	Removal and Installation of S250 Shelter Carrier Rear Suspension Tiedown Kit	2-130

2-53. WINDSHIELD ASSEMBLY OPERATION

WARNING

Do not operate vehicle without windshield assembly positioned upright and the B-pillar securely attached. Operation of vehicle without these structures in place may result in injury to personnel and damage to equipment.

NOTE

Before lowering windshield, windshield retention bracket must be removed. Notify unit maintenance.

a. Lowering Windshield Assembly.

(1) Remove two hitch pins (3) from inside hinge pins (4) and remove hinge pins (4).

(2) Lower windshield assembly (5) to hood and secure windshield assembly (5) to four footman loops (2) with two straps (1).

b. Raising Windshield Assembly.

(1) Remove two straps (1) from four footman loops (2) securing windshield assembly (5) to hood.

(2) Raise windshield assembly (5).

NOTE

Notify unit maintenance to install windshield retention bracket.

(3) Secure windshield assembly (5) with two inside hinge pins (4) and hitch pins (3).

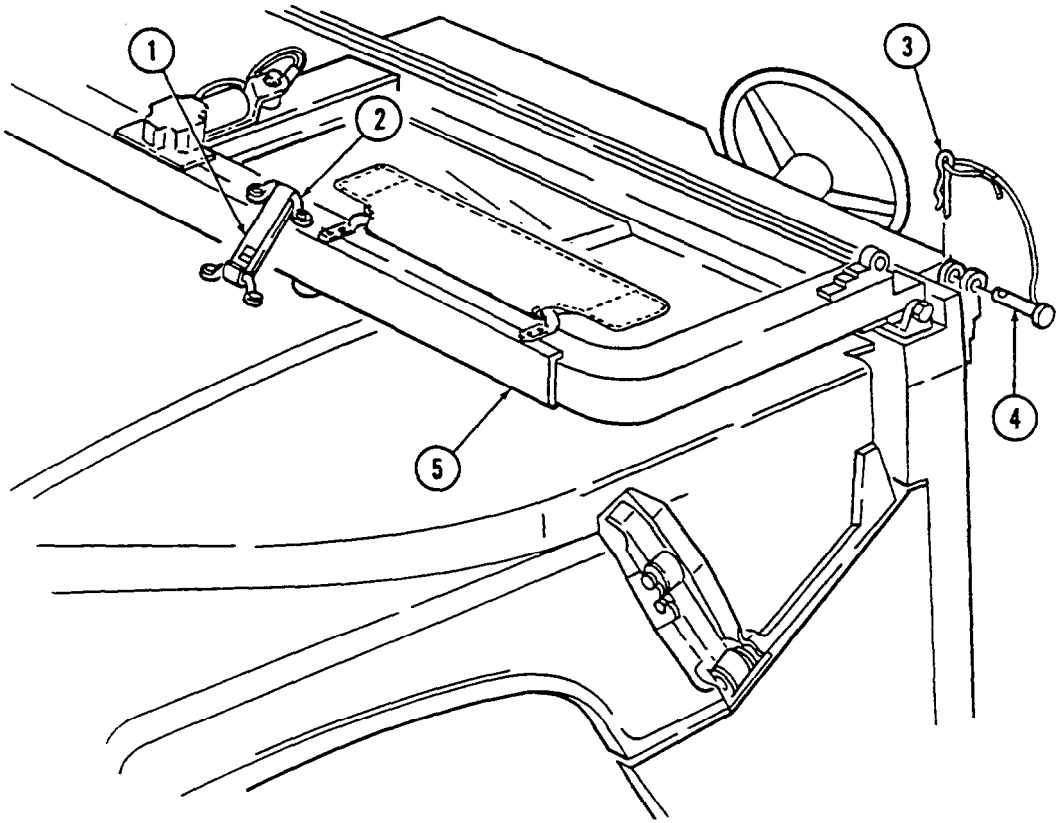

2-54. REMOVAL AND INSTALLATION OF TWO-MAN CREW AREA SOFT TOP ENCLOSURE

NOTE

- For ease of installation, soft top components should be installed when temperature is above 72°F (22°C).
- To keep hinge screws tight, lockwasher NSN 5310-00-527-3634 and locknut NSN 5310-00-241-6658 can be used for installation of soft top doors.
- To prevent seams from leaking, coat with adhesive as needed (appendix D, item 1).

a. General. The two-man soft top enclosure consists of two soft doors, rear curtain, cab roof cover, two rails, and bow assembly.

b. Removal of Soft Top Doors.

- (1) Open door (1) and detach door holding check strap (3) from mounting plate (2).
- (2) Raise door (1) to remove hinge pins (5) from hinge brackets (4).
- (3) Remove door (1) from vehicle.

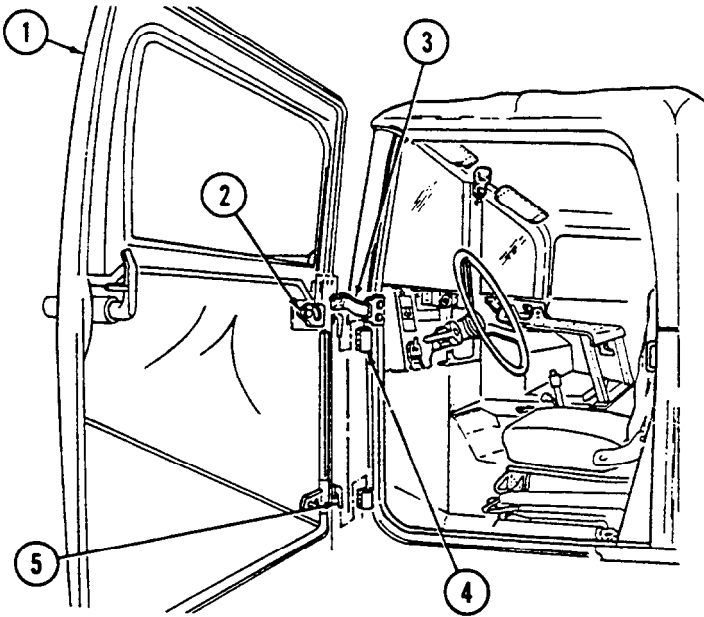

c. Removal of Cab Roof Cover, Rails, and Bow Assembly.

- (1) Unfasten eyelets (7) from turnbuttons (15) on horizontal rails (14), and unfasten hook and loop attachments (9) securing cab roof cover (10) to bow assembly (8).
- (2) Remove cab roof cover (10) from horizontal rails (14).
- (3) Unfasten eyelets (11) from turnbuttons (12) on B-pillar (13) and A-pillar (18).

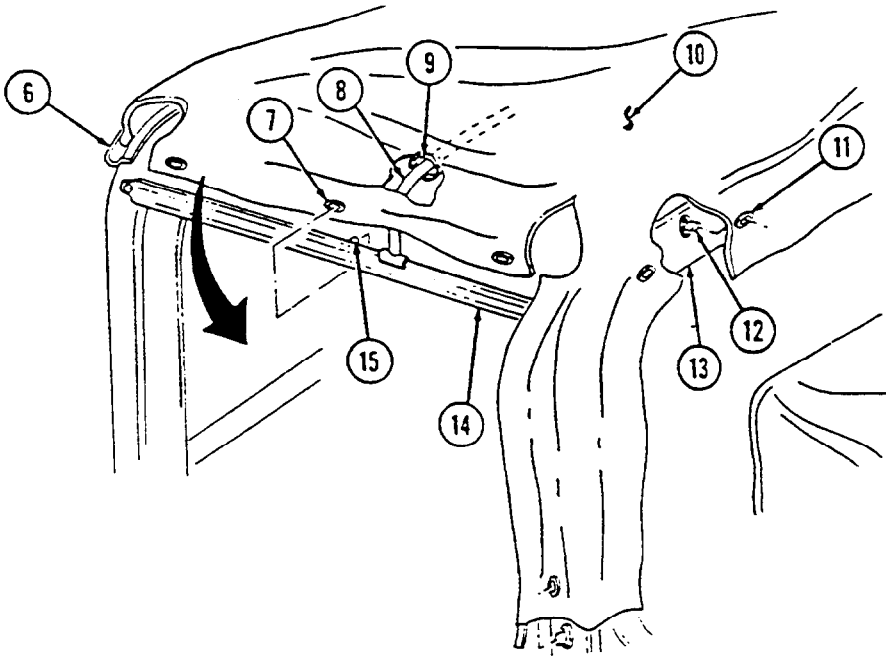

(4) Roll cab roof cover (10) over windshield and slide cab roof cover (10) from channel (6).

(5) Remove four screws (17) and bow assembly (8) from two horizontal rails (14).

(6) Remove four screws (16) securing two horizontal rails (14) to A-pillar (18) and B-pillar (13). Remove horizontal rails (14).

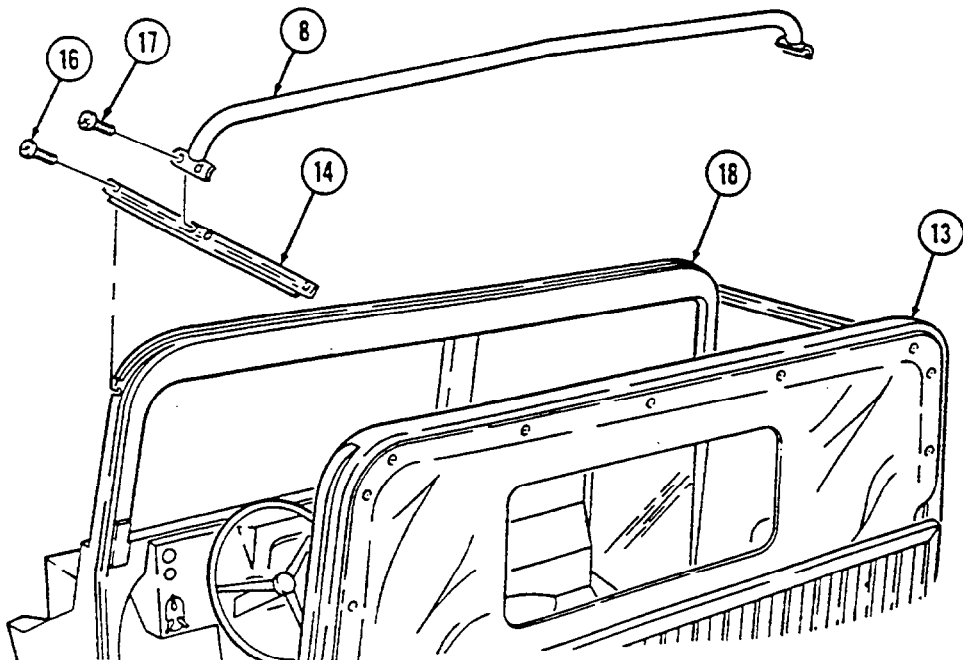

2-54. REMOVAL AND INSTALLATION OF TWO-MAN CREW AREA SOFT TOP ENCLOSURE (Cont'd)

d. Removal of Rear Curtain.

(1) Detach curtain straps (5) from footman loops (7) behind seats by depressing locking tabs (6).

NOTE

Perform step 2 if vehicle is equipped with two-man arctic cab.

- (2) Peel curtain (4) back from fastener tape (8).
- (3) Unfasten eyelets (3) from turnbuttons (2) on B-pillar (1).
- (4) Remove rear curtain (4) from B-pillar (1).

e. Installation of Rear Curtain.

(1) Install rear curtain (4) on B-pillar (1) by fastening eyelets (3) to turnbuttons (2).

NOTE

Perform step 2 if vehicle is equipped with two-man arctic cab.

- (2) Attach curtain (4) to fastener tape (8).
- (3) Attach curtain straps (5) to footman loops (7) located behind seats. Tighten straps (5) equally, but do not overtighten.

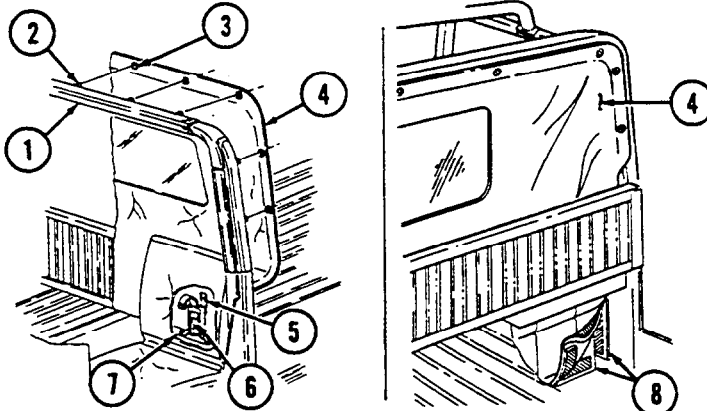

f. Installation of Cab Roof Cover, Rails, and Bow Assembly.

(1) Install two horizontal rails (12) on A-pillar (13) and B-pillar (1), and secure with four screws (9). The short end of horizontal rails (12) goes toward front of vehicle.

(2) Loosen end bracket screws (14) and install bow assembly (11) on horizontal rails (12). Secure with four screws (10) and tighten bracket screws (14).

(3) Slide cab roof cover (18) into channel (15) on A-pillar (13) and roll cab roof cover (18) over cab.

(4) Install cab roof cover (18) over rear curtain (4) at B-pillar (1) and fasten eyelets (3) to turnbuttons (2) on B-pillar (1) and A-pillar (13).

(5) Position cab roof cover (18) around two horizontal rails (12) and fasten eyelets (16) to turnbuttons (19). Secure cab roof cover (18) to bow assembly (11) with hook and loop attachments (17).

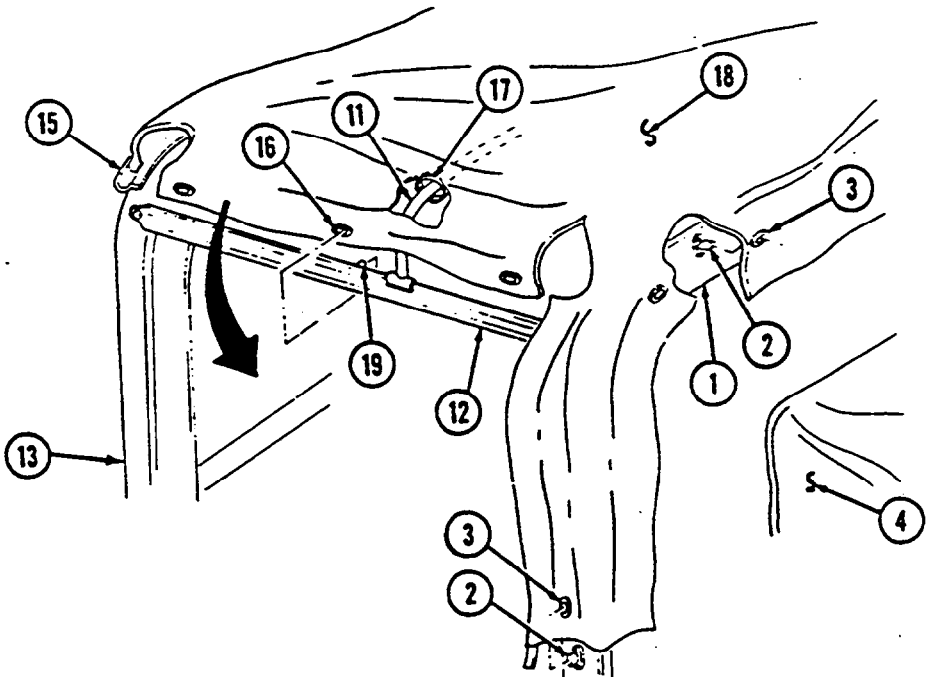
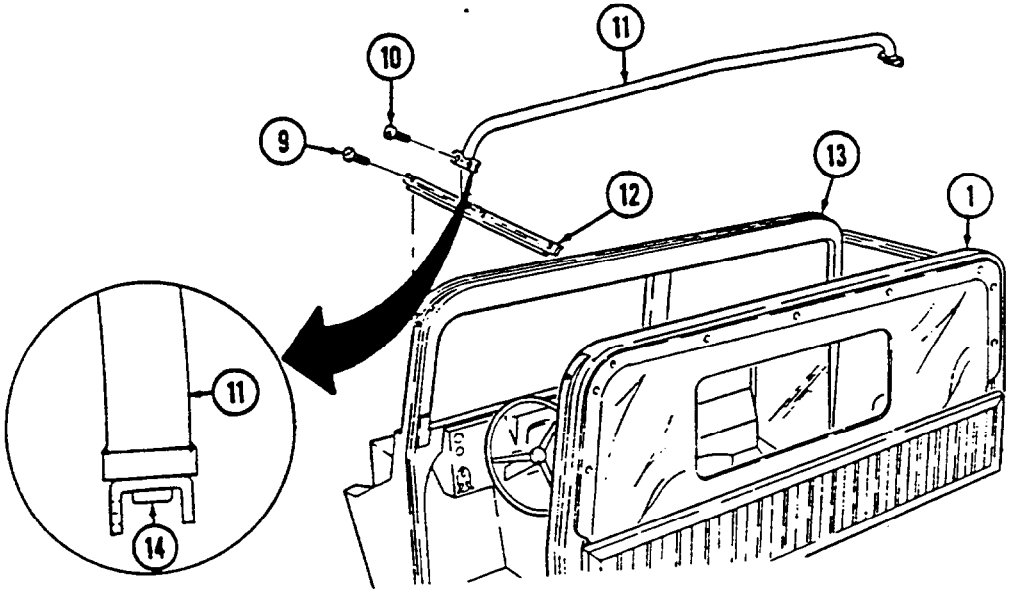

2-54. REMOVAL AND INSTALLATION OF TWO-MAN CREW AREA SOFT TOP ENCLOSURE (Cont'd)

g. Installation of Soft Top Doors.

- (1) Apply a small amount of seasonal grade OE/HDO oil to hinge pins (6), and install door (1) by inserting hinge pins (6) into hinge brackets (5).
- (2) Install door holding check strap (3) on mounting plate (2).
- (3) Close door (1). It may be necessary to adjust door hinges (5) or door latch striker (4) to achieve a tight seal. If adjustment is necessary, notify unit maintenance.

NOTE

When lowering soft top door window, always fold window to inside of vehicle and secure between door and door frame crossmember.

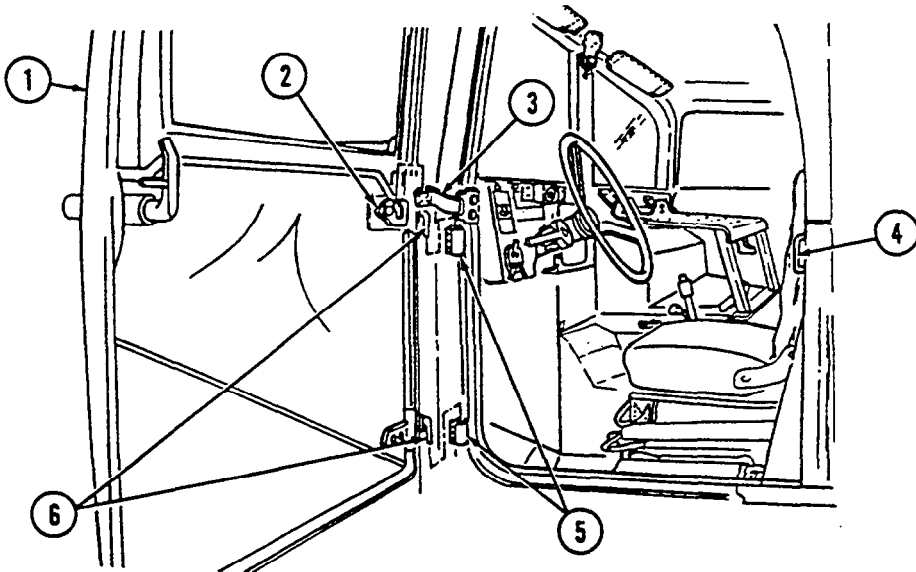

2-55. REMOVAL AND INSTALLATION OF S250 SHELTER CARRIER REAR SUSPENSION TIEDOWN KIT

CAUTION

The M1113 shelter carriers are specifically designed to be operated with the S250 shelter installed. Driving for long distances without the shelter installed, or equivalent payload of 1,500 lb (681 kg) evenly distributed in center of cargo area, will cause damage to equipment. However they can be driven safely without the shelter or an equivalent payload of 1,500 lb (681 kg) for short distances (e.g., to and from maintenance, or from the railhead when being delivered).

NOTE

Rear suspension tiedown kit is to be used only for shipment and should be removed promptly after shipment.

a. Removal of S250 Rear Suspension Tiedown Kit.

(1) Using wrench provided, turn out turnbuckle assembly (6). Unhook from rear-rear tiedown bracket (1) on frame rail (2) and suspension tiedown bar (5).

(2) Remove suspension tiedown bar (5) from lower control arm (3) and shock mount bracket (4).

b. Installation of S250 Rear Suspension Tiedown Kit.

(1) Install suspension tiedown bar (5) into lower control arm (3) and shock mount bracket (4).

(2) Grease threads on turnbuckle assembly (6). Hook turnbuckle assembly (6) to suspension tiedown bar (5) and to rear-rear tiedown bracket (1) on frame rail (2).

(3) With wrench provided, tighten until turnbuckle assembly (6) is completely turned in.

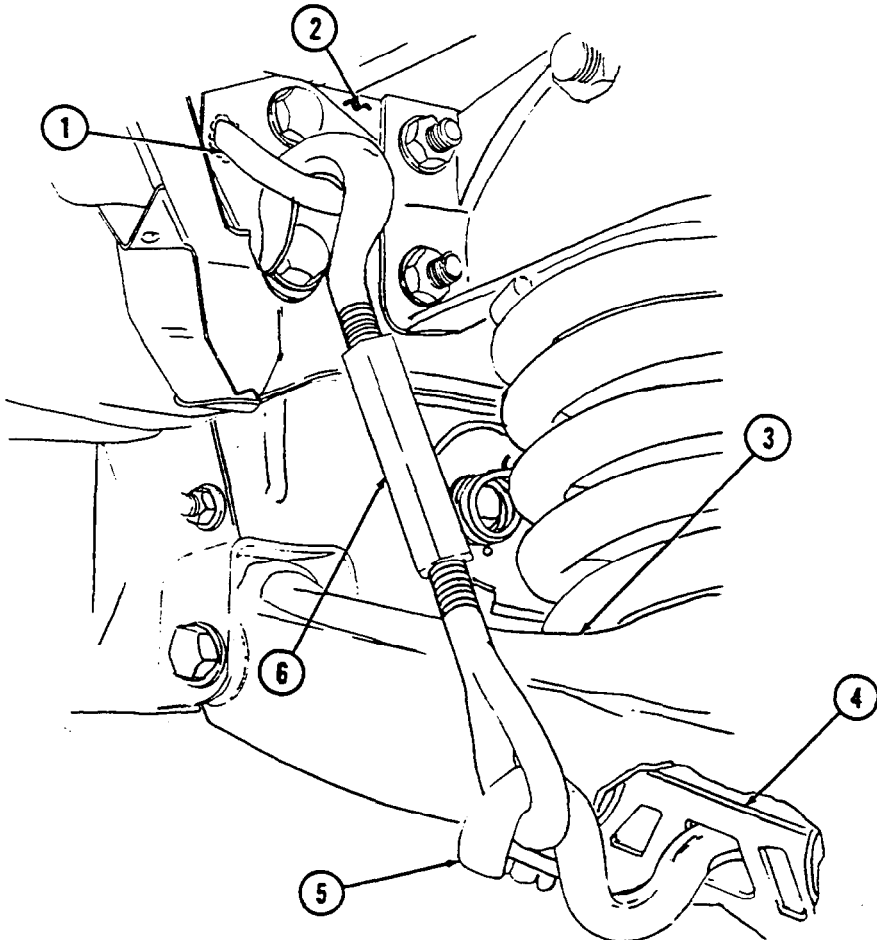

Section VI. M1114 UP-ARMORED CARRIER STOWAGE NET OPERATION

2-56. GENERAL

This section provides instructions for the removal and installation of stowage nets used on the M1114 up-armored carrier.

2-57. M1114 UP-ARMORED CARRIER STOWAGE NET OPERATION REFERENCE INDEX

REF. PARA.	TITLE	PAGE NO.
2-58.	Removal and Installation of Stowage Compartment Net	2-133
2-59.	Removal and Installation of Hatch Stowage Net	2-134
2-60.	Removal and Installation of Rear Seat Stowage Compartment Net	2-135

2-58. REMOVAL AND INSTALLATION OF STOWAGE COMPARTMENT NET**a. Removal.**

Depress locking tabs (1) and unhook net hooks (2) from D-rings (3). Remove net (4).

b. Installation.

Attach net (4) to D-rings (3) with net hooks (2).

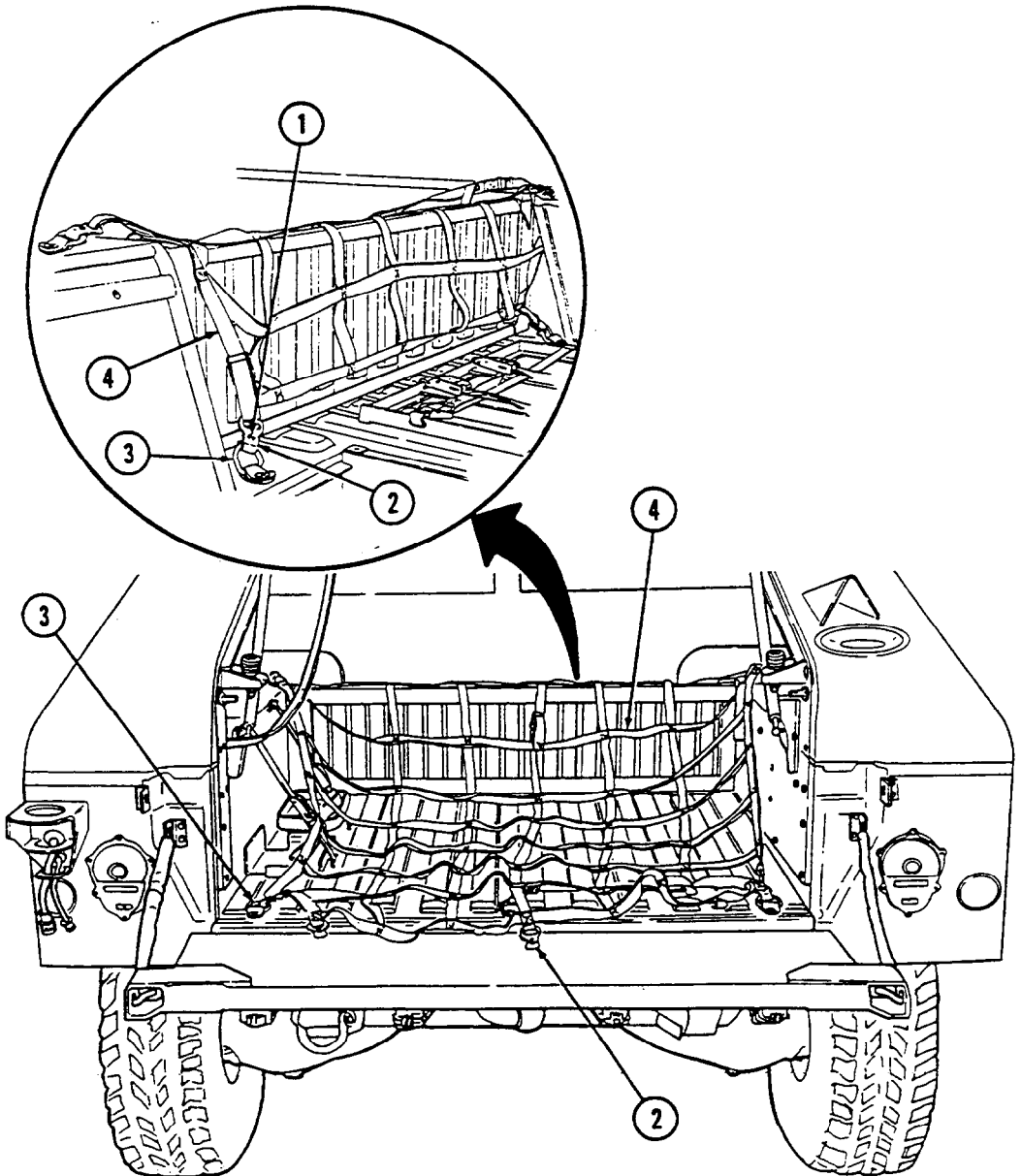

2-59. REMOVAL AND INSTALLATION OF HATCH STOWAGE NET

a. Removal.

- (1) Detach hatch stowage net (1) from side mounted footman loops (3).
- (2) Detach net (1) from top and bottom mounted footman loops (2). Remove net (1).

b. Installation.

- (1) Attach net (1) to top and bottom mounted footman loops (2).
- (2) Attach net (1) to side mounted footman loops (3).

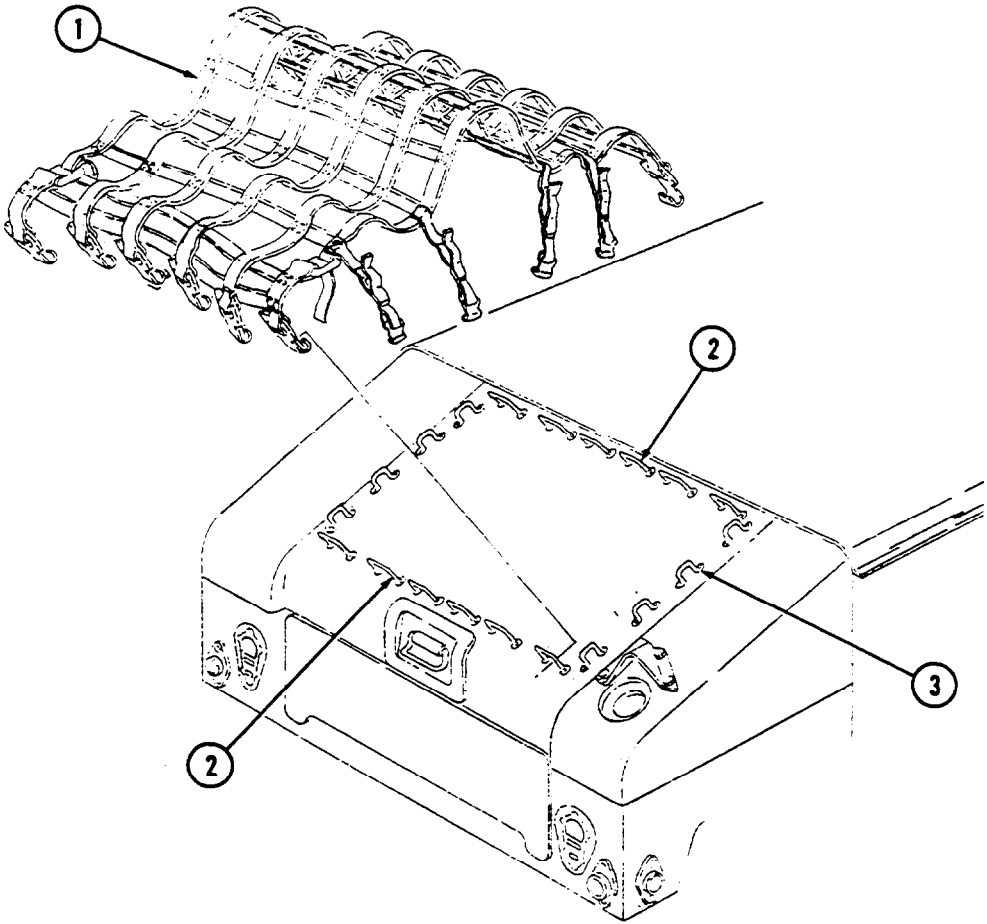

2-60. REMOVAL AND INSTALLATION OF REAR SEAT STOWAGE COMPARTMENT NET**a. Removal.**

Detach locking tabs (1) and unhook compartment net (4) from D-rings (5) and mounting brackets (2) and (3). Remove net (4).

b. Installation.

Attach compartment net (4) to D-rings (5) and mounting brackets (2) and (3).

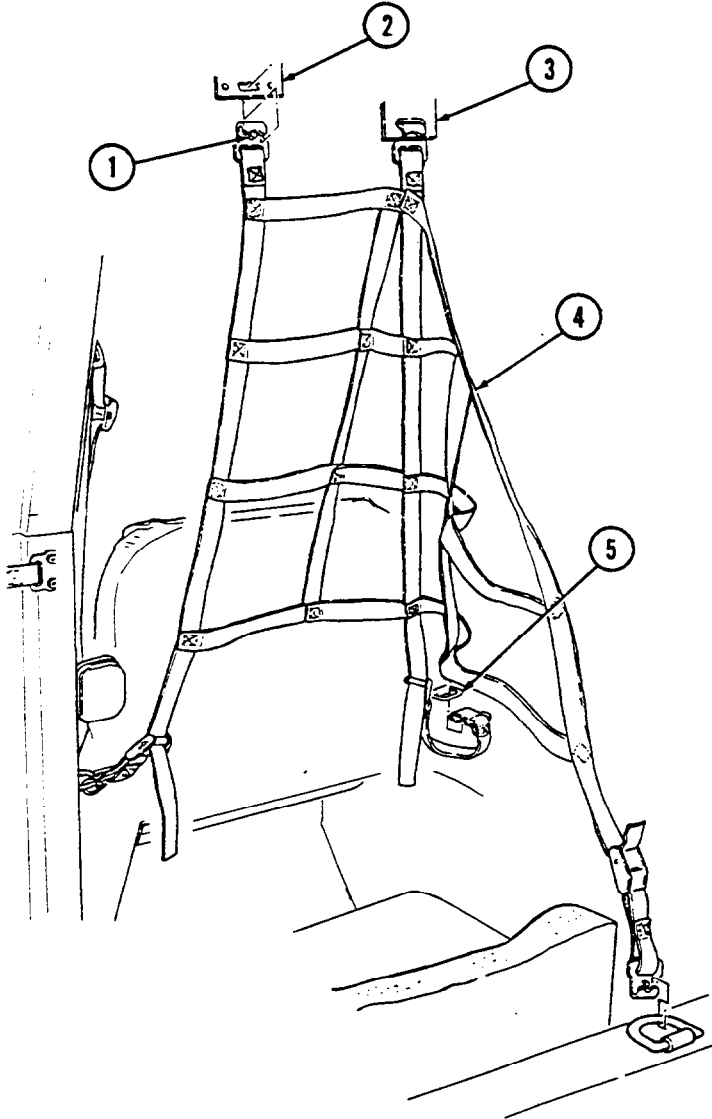

CHAPTER 3 MAINTENANCE INSTRUCTIONS

Section I. LUBRICATION

3-1. LUBRICATION INSTRUCTIONS

Lubrication instructions are in appendix G of this manual. All lubrication instructions are mandatory.

3-2. GENERAL LUBRICATION INSTRUCTIONS

- a. **Service Intervals.** Service intervals on the lubrication instructions are for normal operation in moderate temperatures, humidity, and atmospheric conditions.
- b. **Application Points.** Wipe lubricating points and surrounding surfaces before and after applying lubricant.
- c. **Reports and Records.** Report unsatisfactory performance of lubricant or preserving materials on Product Quality Deficiency Report, SF 368, as stated in para. 1-4.

3-3. GENERAL LUBRICATING INSTRUCTIONS UNDER UNUSUAL CONDITIONS

- a. **Service Intervals.** Increase frequency of lubricating service intervals when operating under abnormal conditions such as high or low temperatures, prolonged high-speed driving, or extended cross-country operations. Such operations can destroy lubricant's protective qualities. More frequent lubricating service intervals are necessary to maintain vehicle readiness when operating under abnormal conditions. During inactive periods, with adequate preservation, service intervals can be extended.
- b. **Changes in Lubricant Grades.** Lubricant grades change with weather conditions. Refer to appendix G for lubricant grade changes.
- c. **Maintaining Lubricant Levels.** Lubricant levels must be checked as specified in appendix G. Steps must be taken to replenish and maintain lubricant levels.

3-4. LUBRICATION FOR CONTINUED OPERATION BELOW 0°F (-18°C)

Refer to FM 9-207, Operation and Maintenance of Ordnance Materiel in Cold Weather (0°F to -65°F) (-18°C to -54°C), or appendix G.

Section II. TROUBLESHOOTING

3-5. GENERAL

Troubleshooting, table 3-1, contains instructions that will help the operator identify and correct simple vehicle malfunctions. The table also helps the operator identify major mechanical difficulties that must be referred to unit maintenance. The listing of possible malfunctions come under major vehicle headings. They are:

- Engine
- Heating system
- Transmission
- Transfer case
- Brakes
- Wheels and tires
- Steering
- Winch
- Up-armored carrier

3-6. TROUBLESHOOTING PROCEDURES

a. Table 3-1 lists the common malfunctions which you may find during the operation or maintenance of the vehicles or their components. You should perform the tests/inspections and corrective actions in the order listed.

b. This manual cannot list all malfunctions that may occur, nor all tests or inspections and corrective actions. If a malfunction is not listed or is not corrected by listed actions, notify your supervisor.

NOTE

- Hydrostatic lock is caused by the entry of substantial amounts of water into the engine through the air intake system and subsequent contamination of the fuel system. Hydrostatic lock most frequently occurs during or just after fording. Water is forced into the air intake system, is drawn into the engine, and effectively locks up the engine.
- Notify unit maintenance if you suspect hydrostatic lock and they will test the engine.

Table 3-1. Troubleshooting.

MALFUNCTION	TEST OR INSPECTION	CORRECTIVE ACTION
-------------	--------------------	-------------------

ENGINE**1. ENGINE FAILS TO CRANK**

- Step 1. Check to see if transmission shift lever is in P (park).
If not, place lever in P (park).
- Step 2. Check battery fluid level and check battery cable connections for looseness, damage, or corrosion.
If any of these conditions exist, notify unit maintenance.
- Step 3. Attempt to slave-start vehicle (para. 2-23).
- Step 4. Other causes.
Notify unit maintenance.

2. ENGINE CRANKS SLOWLY

- Step 1. Check battery fluid level and check battery cable connections for looseness, damage, or corrosion.
If any of these conditions exist, notify unit maintenance.
- Step 2. Attempt to slave-start vehicle (para. 2-23).
- Step 3. Other causes.
Notify unit maintenance.

3. ENGINE CRANKS BUT DOES NOT START

- Step 1. Check to see if fuel gauge indicates E (empty).
Fill fuel tank, and start engine.
- Step 2. Purge fuel system of air (para. 3-11).
- Step 3. Check to see if wait-to-start lamp assembly fails to light or does not go out.
Notify unit maintenance if wait-to-start lamp assembly fails to light or does not go out.
- Step 4. Other causes.
Notify unit maintenance.

4. VEHICLE NOT CHARGING ACCORDING TO VOLTMETER

- Step 1. Check battery cable connections for looseness, damage, or corrosion.
Notify unit maintenance of any damage to battery cables.
- Step 2. Check for broken or missing drivebelt.
Notify unit maintenance if drivebelt is broken or missing.
- Step 3. Other causes.
Notify unit maintenance.

Table 3-1. Troubleshooting (Cont'd).

MALFUNCTION	TEST OR INSPECTION	CORRECTIVE ACTION
-------------	--------------------	-------------------

5. EXCESSIVE EXHAUST SMOKE AFTER ENGINE REACHES NORMAL OPERATING TEMPERATURE 190°-230°F (88°-110°C)

- Step 1. Check oil level for overfilling (appendix G).
Notify unit maintenance if fluid level is high.
- Step 2. Check for restricted air cleaner.
If emergency situation exists, clean air cleaner element (para. 3-15).
If emergency situation does not exist, notify unit maintenance.
- Step 3. Other causes.
Notify unit maintenance.

6. ENGINE STARTS BUT MISFIRES, RUNS ROUGH, OR LACKS POWER

- Step 1. Check for water in fuel filter by draining.
Drain fuel filter (para. 3-11).
- Step 2. Check for restricted air cleaner.
If emergency situation exists, clean air cleaner element (para. 3-15).
If emergency situation does not exist, notify unit maintenance.
- Step 3. Other causes.
Notify unit maintenance.

7. ENGINE OVERHEATS ACCORDING TO ENGINE COOLANT TEMPERATURE GAUGE

- Step 1. Check to see if fan is running.
If fan is not running, perform emergency fan clutch override procedure (para. 3-23).
- Step 2. Allow engine to cool and check for low coolant level.
Add coolant as necessary (para. 3-10).
- Step 3. Check for debris blocking radiator fins.
Remove debris (para. 3-26).
- Step 4. Check for broken or missing drivebelt.
Notify unit maintenance if drivebelt is broken or missing.
- Step 5. Other causes.
Notify unit maintenance.

8. LOW ENGINE OIL PRESSURE ACCORDING TO OIL PRESSURE GAUGE

- Step 1. Check for low oil level (para. 3-18).
Add oil (appendix G).
- Step 2. Other causes.
Notify unit maintenance.

Table 3-1. Troubleshooting (Cont'd).

MALFUNCTION	TEST OR INSPECTION	CORRECTIVE ACTION
-------------	--------------------	-------------------

HEATING SYSTEM

9. HOT WATER PERSONNEL HEATER FAILS TO PRODUCE HEAT AFTER ENGINE REACHES OPERATING TEMPERATURE

Step 1. Check operating controls for correct settings.

Step 2. Other causes.

Notify unit maintenance.

TRANSMISSION

10. NO RESPONSE TO SHIFT LEVER MOVEMENT

Step 1. Check to see if transmission lever is in P (park).

Place transmission shift lever in P and select transfer gear range.

Step 2. Other causes.

Notify unit maintenance.

11. ROUGH SHIFTING

All causes.

Notify unit maintenance.

12. FLUID THROWN FROM TRANSMISSION FILL TUBE

Step 1. Check to see if transmission dipstick is loose.

Secure dipstick.

Step 2. Check fluid level for overfilling (para. 3-19).

Notify unit maintenance if fluid level is high.

Step 3. Other causes.

Notify unit maintenance.

13. SLIPPAGE IN ALL RANGES

Step 1. Check for low fluid level (para. 3-19).

Add fluid (appendix G).

Step 2. Other causes.

Notify unit maintenance.

TRANSFER CASE

14. TRANSFER CASE SHIFT LEVER WILL NOT SHIFT

Step 1. Check for proper shifting sequence.

Ensure proper shifting sequence is used (para. 2-13).

Step 2. Other causes.

Notify unit maintenance.

Table 3-1. Troubleshooting (Cont'd).

MALFUNCTION	TEST OR INSPECTION	CORRECTIVE ACTION
-------------	--------------------	-------------------

BRAKES

15. POOR SERVICE BRAKING ACTION

All causes.

Notify unit maintenance.

16. SERVICE BRAKES DRAGGING

All causes.

Notify unit maintenance.

17. BRAKE WARNING LAMP ASSEMBLY ON

Step 1. Check to see if parking brake is partially applied.
Disengage parking brake.

Step 2. Other causes.
Notify unit maintenance.

18. PARKING BRAKE FAILS TO HOLD VEHICLE

Clean and adjust parking brake (para. 3-13).

If parking brake still fails to hold vehicle, notify unit maintenance.

WHEELS AND TIRES

19. WHEELS WOBBLE OR SHIMMY

Step 1. Check to see if wheel lug nuts are loose.
Tighten loose lug nuts (para. 3-25) and notify unit maintenance to properly torque lug nuts.

Step 2. Inspect for mud or dirt buildup inside the rim.
Remove any mud or dirt buildup.

Step 3. Check tires for proper inflation pressure.

Step 4. Other causes.
Notify unit maintenance.

20. EXCESSIVE OR UNEVEN TIRE WEAR

Step 1. Check tires for proper inflation pressure.

Step 2. Other causes.
Notify unit maintenance.

21. VEHICLE WANDERS TO ONE SIDE ON LEVEL PAVEMENT

Step 1. Check tires for proper inflation pressure.

Step 2. Other causes.
Notify unit maintenance.

Table 3-1. Troubleshooting (Cont'd).

MALFUNCTION	TEST OR INSPECTION	CORRECTIVE ACTION
-------------	--------------------	-------------------

STEERING

22. HARD STEERING

- Step 1. Check tires for proper inflation pressure.
- Step 2. Check power steering reservoir for low fluid level (para. 3-20).
Add steering fluid (appendix G).
- Step 3. Check for broken or missing drivebelt.
Notify unit maintenance if drivebelt is broken or missing.
- Step 4. Check power steering oil cooler for bent fins or any other air flow obstructions.
Remove obstructions if fins are not damaged.
Notify unit maintenance if power steering oil cooler is damaged.
- Step 5. Other causes.
Notify unit maintenance.

WINCH

23. WINCH STOPS DURING NORMAL OPERATION

- Step 1. Wait 2 minutes and attempt winch operation again.
Refer to para. 2-28 for winch operation.
- Step 2. Check to see if clutch lever is engaged (para. 2-28).
If not, engage clutch lever.
- Step 3. Check to see if voltmeter is in red or yellow (engine not running).
Start engine and charge batteries.
- Step 4. Other causes.
Notify unit maintenance.

UP-ARMORED CARRIER

24. WEAPON STATION WILL NOT ROTATE OR LOCK

- Step 1. Check for obstructions that may be restricting weapon station movement.
Remove obstructions.
- Step 2. Other causes.
Notify unit maintenance.

25. CARGO SHELL DOOR WILL NOT SEAL PROPERLY

- All causes.
Notify unit maintenance.

Section III. MAINTENANCE PROCEDURES

3-7. GENERAL

The operator/crew is responsible for daily, weekly, and monthly preventive maintenance checks and services listed in table 2-2. Other maintenance services, also the responsibility of the operator/crew, are explained in this section.

3-8. MAINTENANCE PROCEDURES REFERENCE INDEX

REF. PARA.	TITLE	PAGE NO.
3-9.	Raising and Securing Hood	3-8
3-10.	Servicing Coolant Surge Tank	3-10
3-11.	Fuel Filter Maintenance	3-11
3-12.	Servicing Batteries	3-12
3-13.	Parking Brake Adjustment and Cleaning	3-13
3-14.	Servicing Windshield Washer Reservoir	3-14
3-15.	Air Cleaner Servicing (Emergency Procedure)	3-14
3-16.	Air Cleaner Dump Valve Servicing	3-17
3-17.	Plastic Window Cleaning	3-18
3-18.	Engine Oil Servicing	3-19
3-19.	Transmission Fluid Servicing	3-20
3-20.	Power Steering Fluid Servicing	3-21
3-21.	Fuel Tank Servicing	3-22
3-22.	Tire Chain Installation and Removal	3-24
3-23.	Emergency Fan Clutch Override	3-26
3-24.	Rearview Mirror Adjustment	3-27
3-25.	Wheel Assembly Replacement	3-28
3-26.	Radiator Cleaning	3-30

3-9. RAISING AND SECURING HOOD

WARNING

To ensure opening of the hood assembly is accomplished safely and effectively, always maintain the proper lifting posture, legs bent with back straight. Failure to do so may cause injury.

NOTE

Due to the inherent weight of the hood assembly, hood may flex when opening, possibly causing interference between the right side of hood assembly and body. This interference can be eliminated by pushing hood assembly laterally away from individual prior to lifting.

a. Raising Hood.

- (1) Apply parking brake.
- (2) Release left and right hood latches (1).
- (3) Facing driver's side of hood, position one hand at the rear area of hood and other at rear area of wheel well.

WARNING

When raising and securing hood, ensure hood prop rod is secured to hood support bracket. Damage to equipment or injury to personnel may occur if hood is not properly secured in raised position.

- (4) Open hood assembly, ensuring hood prop rod (2) is securely positioned in hood support bracket (3). The prop rod (2) should automatically engage support bracket (3) when hood is raised.

b. Lowering Hood.**WARNING**

When releasing hood prop rod, do not pull rod at hook end. Injury to fingers may occur.

- (1) While supporting and slightly raising hood, grasp prop rod (2) above retaining ring (5), pull out, and release hood prop rod (2).
- (2) Once prop rod hook (4) is clear of support bracket (3), slowly lower hood and secure left and right hood latches (1).

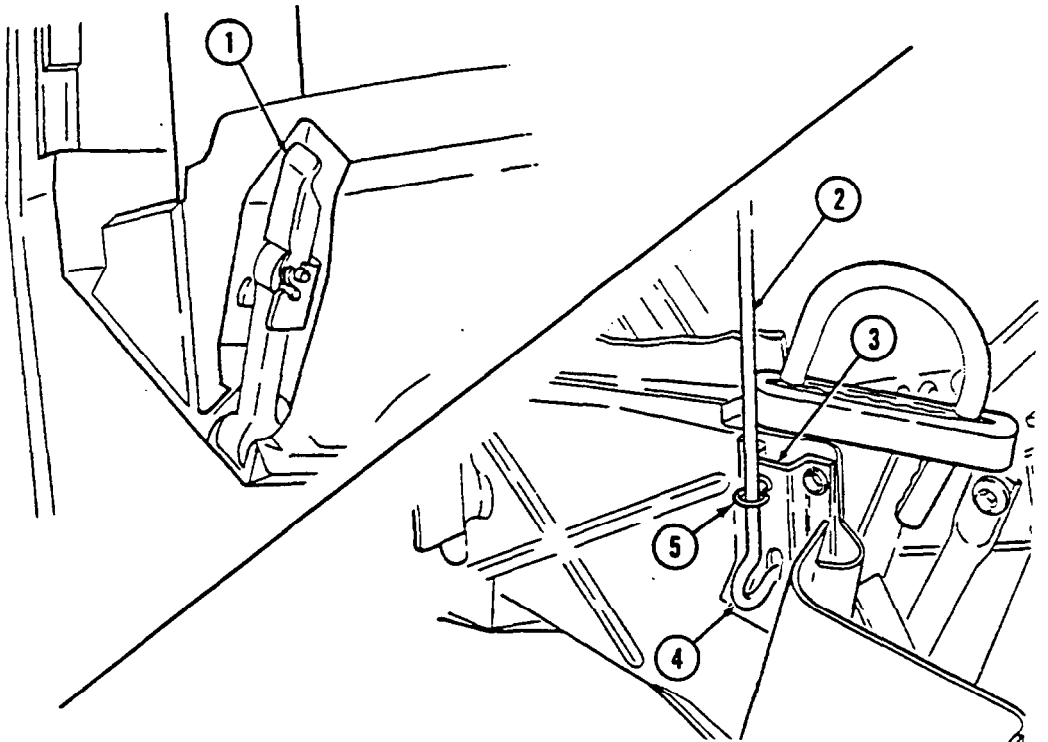

3-10. SERVICING COOLANT SURGE TANK

WARNING

Extreme care should be taken when removing surge tank filler cap if temperature gauge reads above 165°F (74°C). Do not add coolant to cooling system when engine is hot unless engine is running. Add coolant slowly. Steam or hot coolant under pressure may cause injury.

- a. Raise and secure hood (para. 3-9).
- b. Visually check coolant level. Surge tank level should be at **COLD FILL LINE** before operation and slightly above **COLD FILL LINE** after operation. If coolant is low, perform steps c through h.
- c. Place a thick cloth over surge tank filler cap (1). Carefully turn cap (1) counterclockwise to its first stop to allow cooling system pressure to escape.
- d. After cooling system pressure is vented, push down and turn cap (1) counterclockwise to remove. Add coolant until surge tank level is at **COLD FILL LINE**.
- e. Start engine (para. 2-12) and run for one minute.
- f. Stop engine (para. 2-14) and recheck coolant level. If coolant level is low, add coolant until surge tank level is at **COLD FILL LINE**.
- g. Repeat steps e and f until surge tank level remains at **COLD FILL LINE**.
- h. Install cap (1). Lower and secure hood (para. 3-9).

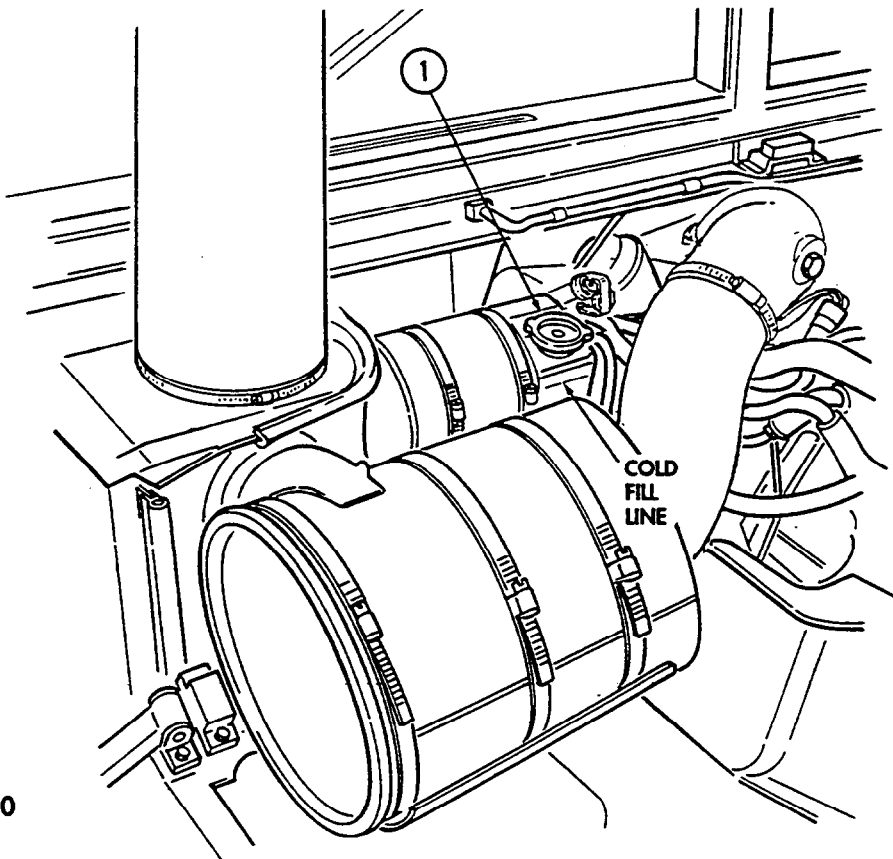

3-11. FUEL FILTER MAINTENANCE

WARNING

Do not perform fuel system checks, inspection, or maintenance while smoking or near fire, flames, or sparks. Fuel may ignite, causing damage to vehicle and injury or death to personnel.

a. Draining Fuel Filter.

- (1) Raise and secure hood (para. 3-9).
- (2) Start engine (para. 2-12).
- (3) Place toggle fuel switch (3) to the UP position and allow approximately 1 pt (0.47 L) of fuel to drain into a suitable container.
- (4) Place toggle fuel switch (3) to the DOWN position when draining is complete.
- (5) Stop engine (para. 2-14).
- (6) Lower and secure hood (para. 3-9).

b. Purging Fuel System of Air.

NOTE

This procedure is used to purge fuel system of air if vehicle has run out of fuel.

- (1) Raise and secure hood (para. 3-9).
- (2) Disconnect fuel line (1) from fuel filter outlet (2).
- (3) Place a rag over fuel filter outlet (2).
- (4) Crank engine until rag is wet with fuel.
- (5) Connect fuel line (1) to fuel filter outlet (2).
- (6) Start engine (para. 2-12) and ensure fuel system has been purged of air.
- (7) Lower and secure hood (para. 3-9).

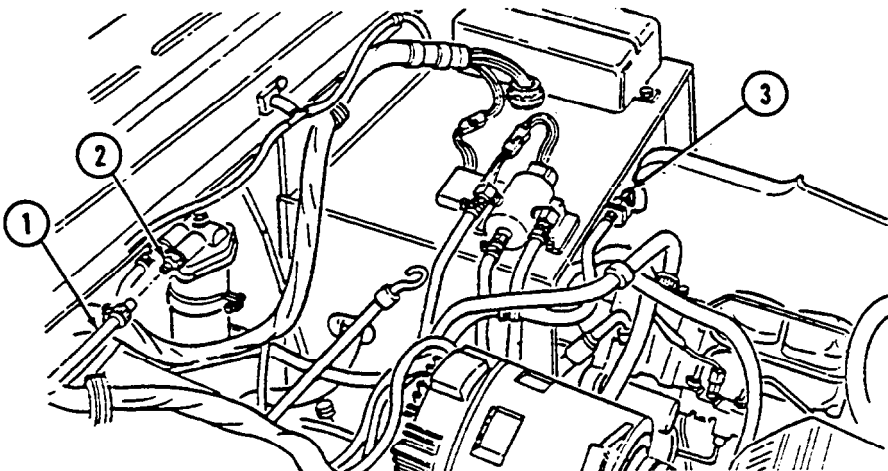

3-12. SERVICING BATTERIES

- a. Unhook latches (6) and remove companion seat (1) from battery box (9).

WARNING

Do not perform battery system checks or inspections while smoking or near fire, flames, or sparks, especially if the caps are off. Batteries may explode, causing damage to vehicle and injury or death to personnel.

- b. Check electrolyte level.

(1) Remove all battery filler caps (2) and check electrolyte level. If electrolyte level is below ledge in battery filler opening, add distilled water (appendix D, item 7).

(2) A battery that is continually in need of electrolyte may indicate an improperly adjusted charging system. Notify unit maintenance if problem continues.

(3) Inspect vented battery filler caps (2) to ensure that vents are clear, unobstructed, and permit escape of battery gases. Clean vents if obstructed; replace caps (2) if damaged.

- (4) Install filler caps (2).

c. Inspect all battery compartment components, including terminal clamps (5), battery cables (3), battery holddowns (8), and shunt (4) for corrosion, damage, or looseness. Inspect terminal boots (7), if installed. Notify unit maintenance if any of these problems exist.

d. Ensure that battery terminal clamps (5) have a light coat of lubricating oil for corrosion protection (appendix D, item 23).

- e. Install companion seat (1) and secure to battery box (9) with latches (6).

- f. Refer to TM 9-6140-200-14 for additional information.

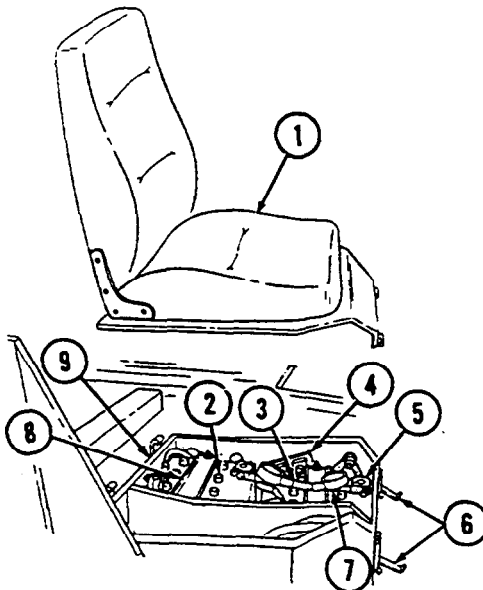

3-13. PARKING BRAKE ADJUSTMENT AND CLEANING

- a. Chock wheels and release parking brake handle (3) by depressing safety release button (2).
- b. Turn adjusting knob (1) clockwise as tightly as possible by hand.
- c. Apply parking brake handle (3).
- d. If parking brake cannot be applied, turn adjusting knob (1) counterclockwise until parking brake can be applied.
- e. Test parking brake.
 - (1) Remove chocks.
 - (2) Depress service brake pedal and start engine (para. 2-12).
 - (3) Place transfer case shift lever (4) in H (high) and transmission shift lever (5) in \odot (overdrive).
 - (4) Slowly let up on service brake pedal. Parking brake should hold vehicle stationary.
- f. After operating in mud or sand, use a low-pressure water source to ensure actuating lever (7) and spring (6) are thoroughly cleaned of mud, sand, or other debris. Lubricate lever (7) in accordance with appendix G as soon as possible.

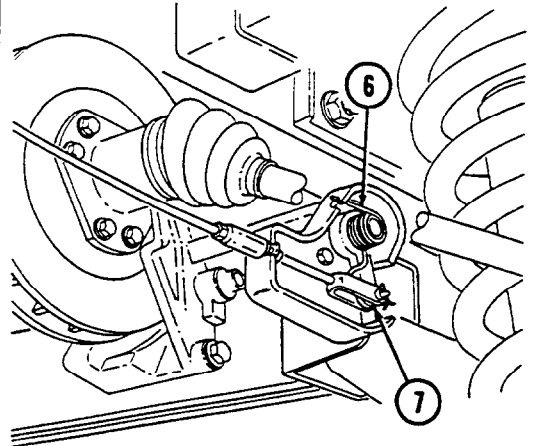
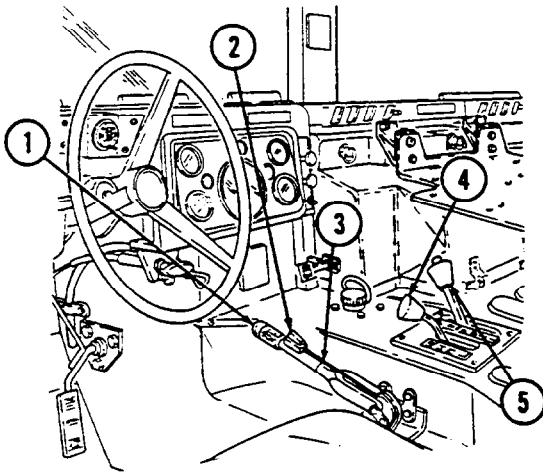

3-14. SERVICING WINDSHIELD WASHER RESERVOIR

- a. Raise and secure hood (para. 3-9).
- b. Check fluid level in washer reservoir (2). Check frequently under adverse weather conditions.
- c. If fluid is required, fill washer reservoir with water and cleaning compound (appendix D, item 4), refer to table 3-2.

Table 3-2. Cleaning Compound-to-Water Ratio.

Temperature Range	Cleaning Compound	to	Water
Above +15°F (-9°C)	1	to	2
+40° to -15°F (+4° to -26°C)	1	to	1
+40° to -65°F (+4° to -54°C)	2	to	1

- d. If washer system does not work, check washer nozzles (1) to see if they are blocked with dirt and/or debris. Remove dirt and/or debris with fine wire.
- e. Check hoses (3) for leaks or poor condition.
- f. Lower and secure hood (para. 3-9).

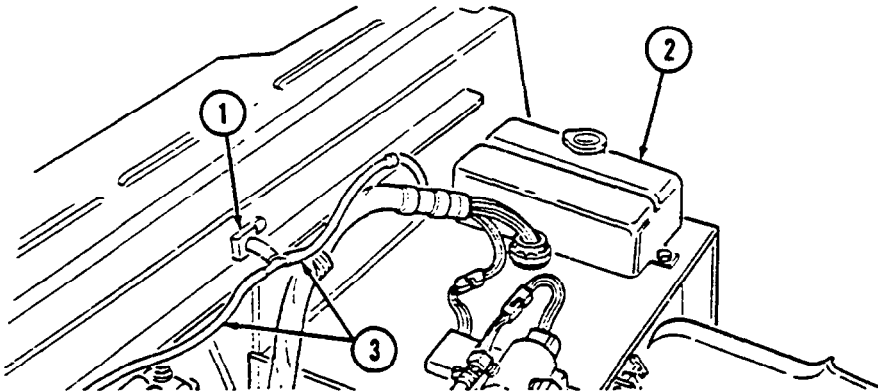

3-15. AIR CLEANER SERVICING (EMERGENCY PROCEDURE)

- a. **General.** Air cleaner service is required when yellow air restriction indicator (3) reaches red zone (2) of gauge (1).

CAUTION

Do not operate engine without air cleaner element. Damage to engine may result.

- b. **Filter Element Removal.**
 - (1) Raise and secure hood (para. 3-9).
 - (2) Loosen clamp screw (10) and remove clamp (4) and cover (5) from air cleaner assembly (8).

WARNING

- NBC contaminated filters must be handled using adequate precautions (FM 3-5) and must be disposed of by trained personnel.
- After Nuclear, Biological, or Chemical (NBC) exposure of this vehicle, all air filters shall be handled with extreme caution. Unprotected personnel may experience injury or death if residual toxic agents or radioactive material are present. Servicing personnel will wear protective overgarments, mask, hood, and chemical-protective gloves and boots. All contaminated air filters will be placed into double-lined plastic bags and moved immediately to a temporary segregation area away from the work site. If contaminated by radioactive dust, the Company NBC team will measure the radiation before removal. The NBC team will determine the extent of safety procedures required. The temporary segregation area will be marked with the appropriate NBC signs. Final disposal of contaminated air filters will be in accordance with local Standard Operating Procedures (SOP).
- Failure to observe above warnings may result in injury or death.

(3) Remove nut and washer assembly (6) securing filter element (7) to stud (9) and pull filter element (7) from air cleaner assembly (8).

(4) Place cover (5) and clamp (4) back on air cleaner assembly (8) to prevent dirt and dust from entering air induction system while cleaning filter element (7).

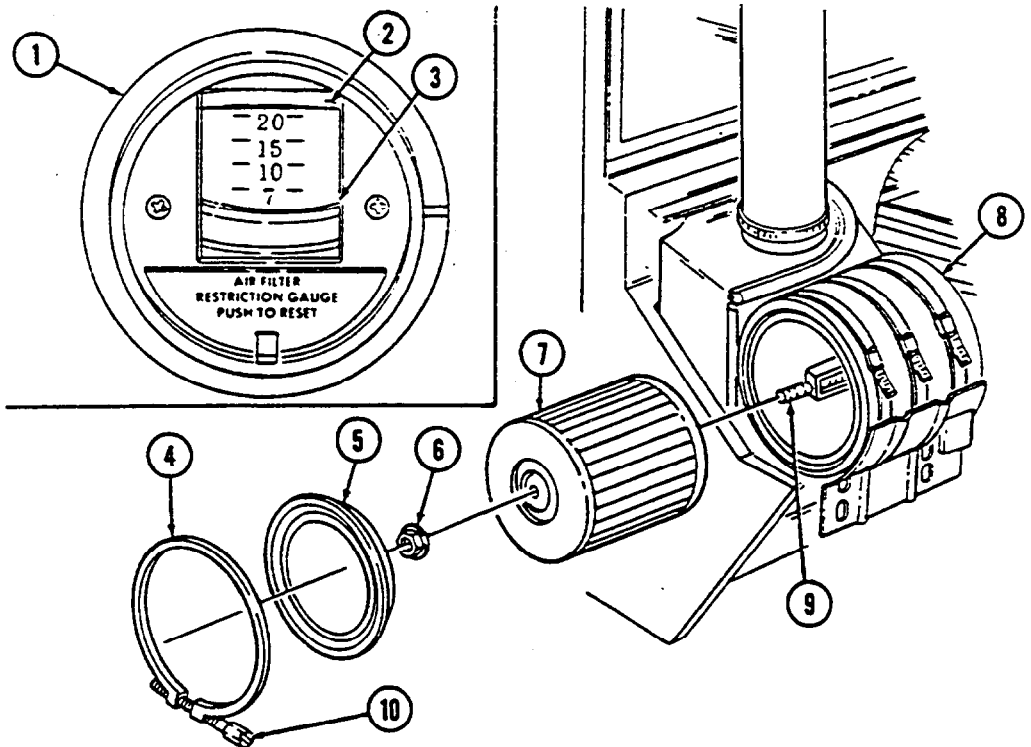

3-15. AIR CLEANER SERVICING (EMERGENCY PROCEDURE) (Cont'd)

c. Air Filter Element Cleaning.

CAUTION

Do not strike ends of filter element on hard surface, or damage to filter element may result.

- (1) Hold filter element (1) with open end facing ground.
- (2) Gently tap completely around filter element (1) with hand to free trapped dirt.

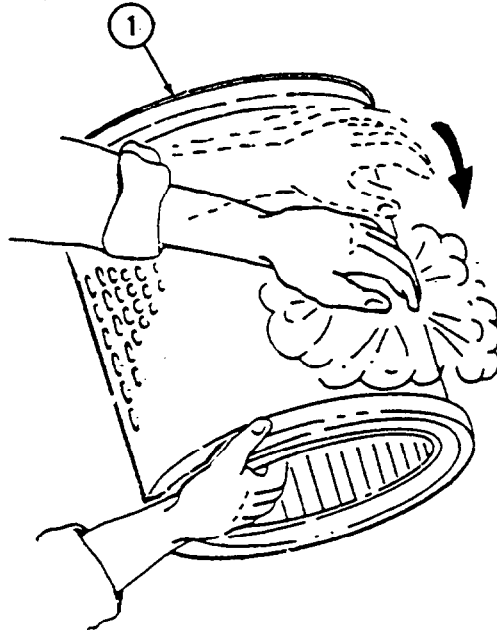

d. Filter Element Installation.

CAUTION

The turbocharged engine requires a 420CFM filter element. Use of any other filter element will damage equipment.

- (1) Remove clamp (2) and cover (3) from air cleaner assembly (5).
- (2) Position filter element (1) into air cleaner assembly (5) and secure element (1) to stud (6) with nut and washer assembly (4).

CAUTION

When clamp is secured to end of air cleaner, ensure clamp screw is between three and six o'clock positions to prevent damaging hood when hood is closed.

- (3) Install cover (3) and clamp (2) on end of air cleaner assembly (5) and tighten clamp screw (7).
- (4) Lower and secure hood (para. 3-9).

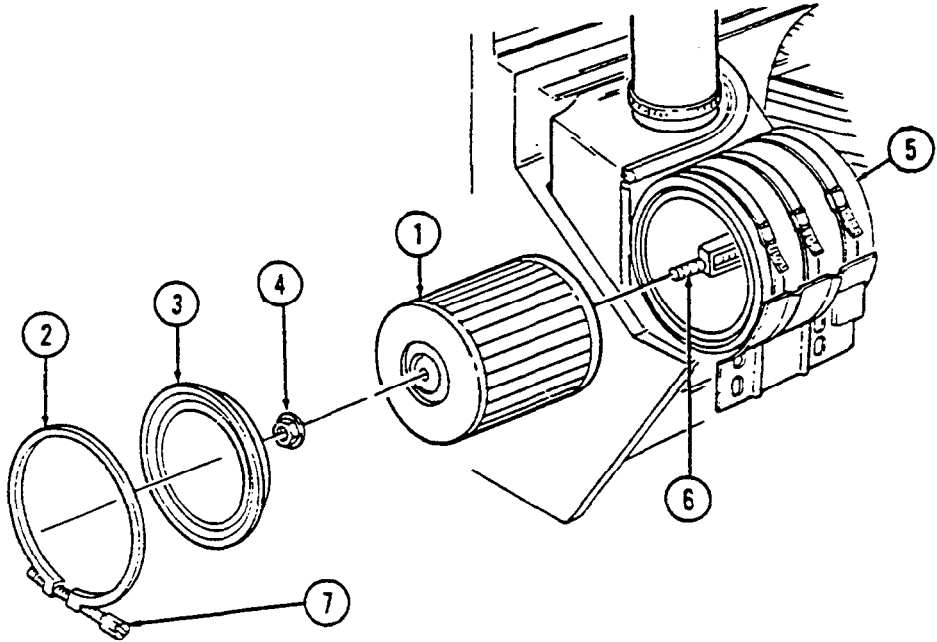

3-16. AIR CLEANER DUMP VALVE SERVICING

NOTE

Air cleaner dump valve should be serviced after any operation through sand, mud, or water.

- a. Raise and secure hood (para. 3-9).
- b. Squeeze dump valve (2) to clear any sand, mud, or water from air cleaner assembly (1).
- c. For vehicles equipped with a deep water fording kit, loosen clamp (3) and remove cap (4). Clean and install cap (4) and tighten clamp (3).
- d. Lower and secure hood (para. 3-9).

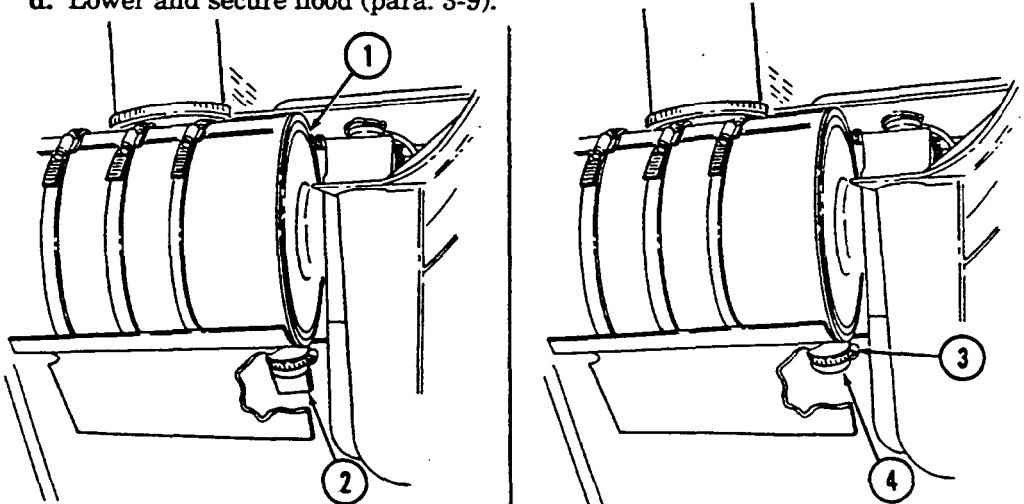

3-17. PLASTIC WINDOW CLEANING

CAUTION

Never clean plastic windows with abrasives. Repeated use of abrasives or failure to follow instructions below will eventually cause damage to windows.

NOTE

This paragraph provides instructions for cleaning soft top plastic windows and ballistic windshield and windows. This procedure is to be used on the inner plastic laminate surfaces of ballistic glass. Clean outer surface of ballistic glass as you would plain glass.

a. Plastic Window Cleaning.

- (1) Wash windows using soap, water, and a soft, clean cloth.
- (2) Rinse with clean water.
- (3) Apply cream cleaner (appendix D, item 5) to plastic windows.
- (4) Wipe cream cleaner off with dry cloth. Cream cleaner improves visual clarity after cleaning with soap and water.

b. Ballistic Glass Cleaning.

CAUTION

- Do not clean interior surfaces of ballistic glass by any other means than specified below.
- Do not use a scraper or other objects with sharp edges that may scratch the inside surfaces of ballistic glass.
- Do not apply stickers, labels, solvents, abrasive materials, or cleaners.

(1) Remove dust and loose abrasive particles using clean, filtered air at 20 psi (138 kPa) maximum.

(2) Wash with mild detergent (appendix D, item 6) and warm water. Dry using a soft, clean cloth.

(3) Remove stubborn marks and stains using a soft, clean cloth and equal parts by volume of isopropyl alcohol (appendix D, item 18) in water.

(4) Repeat step (2).

3-18. ENGINE OIL SERVICING

- a. Raise and secure hood (para. 3-9).

CAUTION

Do not permit dirt, dust, or grit to enter engine oil dipstick tube. Internal engine damage may result if engine oil becomes contaminated.

NOTE

- Engine oil level is checked with engine off.
 - If oil level checks above FULL, it may be due to oil cooler drain-back. Operate engine for one minute, shut down, wait one minute, and recheck oil level. If it still checks above full, drain oil to obtain correct level.
 - Vehicles equipped with deep water fording kit will have a sealed dipstick.
- b. Pull out dipstick (1) and check for proper oil level. Level should be at crosshatch marks (2) between FULL and ADD 1 QT.

CAUTION

Do not overfill engine crankcase. Damage to engine may result.

- c. If engine oil is low, remove oil filler cap (3) and add engine oil (appendix G).

CAUTION

Use a non-vented filler cap only. An incorrect filler cap will not seal properly, causing water to enter and damage engine.

- d. Replace oil filler cap (3), tighten securely, and wipe away any spilled oil.
e. Lower and secure hood (para. 3-9).

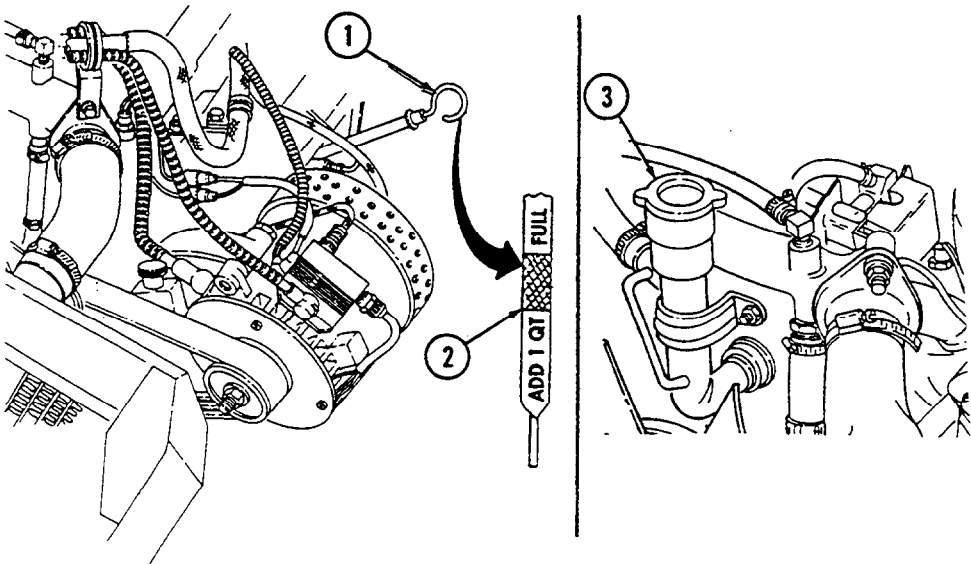

3-19. TRANSMISSION FLUID SERVICING

- a. Raise and secure hood (para. 3-9).
- b. Start engine (para. 2-12).
- c. While depressing service brake pedal, move transmission shift lever through all operating ranges and R (reverse) before checking fluid level in N (neutral) with parking brake applied.

CAUTION

Do not permit dirt, dust, or grit to enter transmission oil dipstick tube. Internal transmission damage may result if transmission fluid becomes contaminated.

- d. Pull out dipstick (2) and check for proper transmission fluid level. At normal operating temperature, fluid level should be at crosshatch marks (3).

CAUTION

Do not overfill transmission. Damage to transmission may result.

- e. If transmission fluid level is low, add fluid (appendix G) through fill pipe (1), insert dipstick (2), and wipe away any spilled fluid.
- f. Shut off engine (para. 2-14).
- g. Lower and secure hood (para. 3-9).

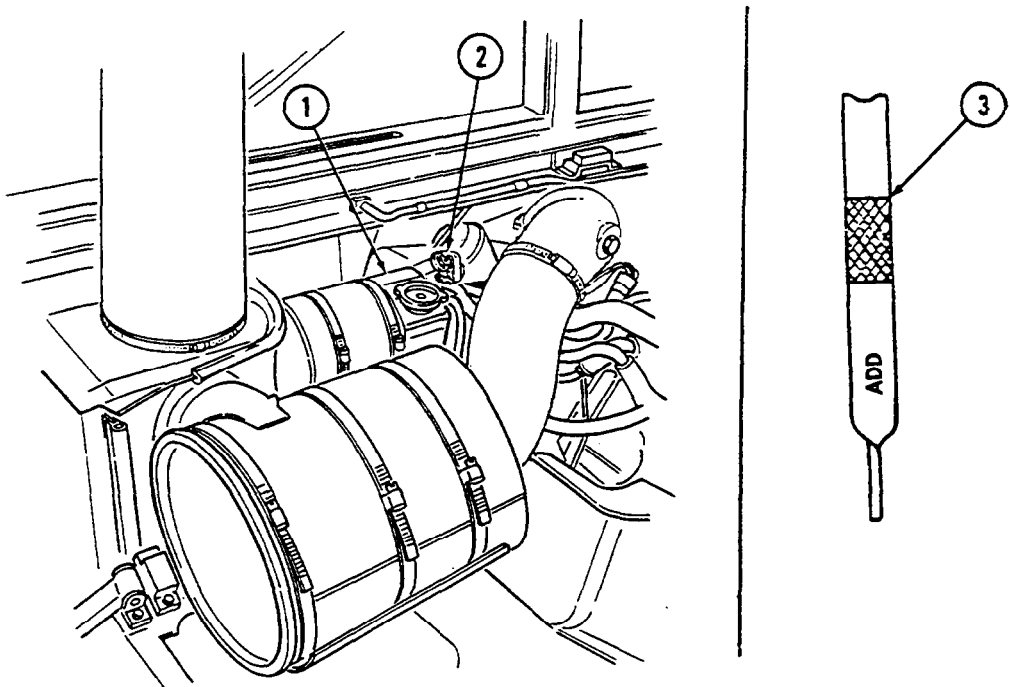

3-20. POWER STEERING FLUID SERVICING

- a. Raise and secure hood (para. 3-9).

CAUTION

Do not permit dirt, dust, or grit to enter power steering reservoir. Damage to power steering system may result if power steering fluid becomes contaminated.

- b. Remove cap/dipstick (2) and check steering fluid level. If engine is warm, level should be between HOT and COLD marks. If engine is cool, level should be between ADD and COLD marks. In either condition, fluid must be added if level reads below ADD mark.

CAUTION

Do not overfill power steering reservoir. Damage to power steering system will result.

- c. If fluid level is low, add fluid (appendix G) to power steering reservoir (1) and wipe away any fluid spilled.
 d. Install cap/dipstick (2).
 e. Lower and secure hood (para. 3-9).

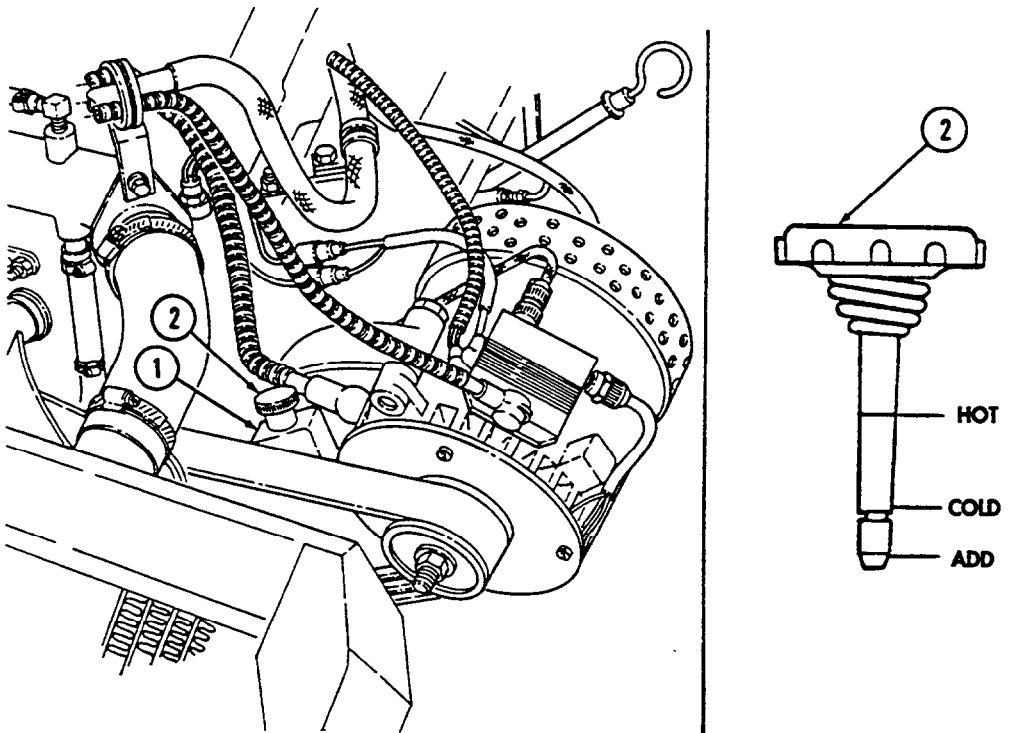

3-21. FUEL TANK SERVICING

- a. Shut off engine (para. 2-14).

WARNING

Do not perform fuel system checks, inspection, or maintenance while smoking or near fire, flames, or sparks. Fuel may ignite, causing damage to vehicle and injury or death to personnel.

CAUTION

Do not turn fuel cap handle more than necessary to remove or seal fuel cap. Fuel cap chain links may separate or become damaged.

NOTE

For M1114 vehicles, the fuel door must be open before removing fuel cap (para. 2-34).

- b. Turn fuel cap handle (1) on fuel cap (2) counterclockwise and remove fuel cap (2).

CAUTION

When refueling vehicle, be careful that nozzle does not slam into filler pipe. Damage to strainer may occur, allowing dirty fuel to clog up filters.

NOTE

To help prevent spills and overflows, pay close attention to the dispensing nozzle while refueling. Do not exceed a safe refueling rate. If fuel backup and spillage is being experienced, reduce flow rate. Also, when topping off the tank, a reduced flow rate should be used.

- c. Insert fuel filler nozzle into filler neck rubber cone, using caution not to puncture fuel filler neck strainer. Dispense fuel into fuel tank.

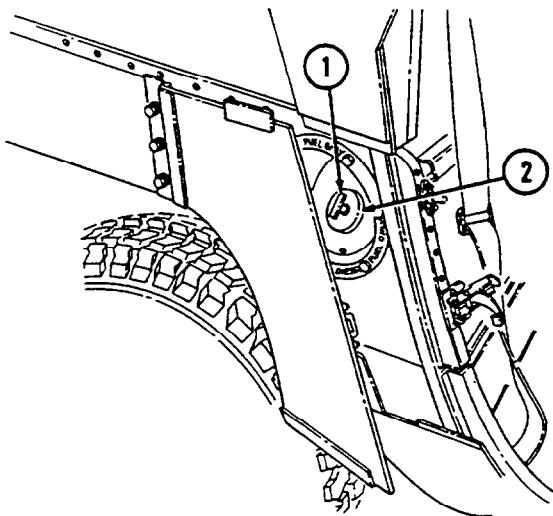

d. If fuel cap handle (1) is turned more than necessary to remove fuel cap (2), fuel cap backing plate (3) may become jammed on staked threads (4). Correct the problem by holding backing plate (3) and turning the fuel cap handle (1) clockwise until backing plate (3) turns freely.

e. When fueling operation is complete, install fuel cap (2) and turn fuel cap handle (1) clockwise to seal fuel cap (2).

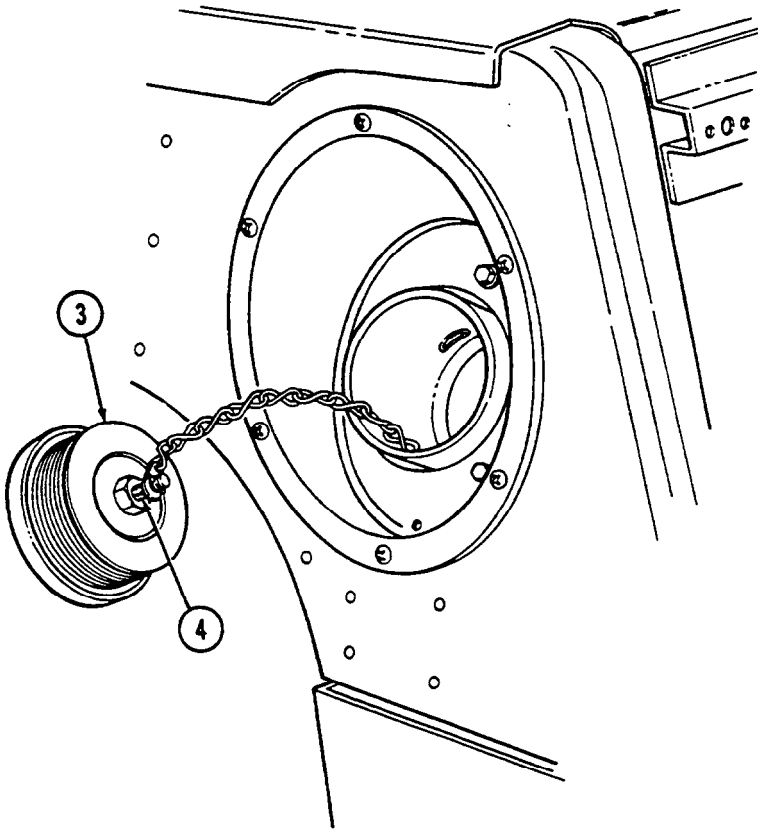

3-22. TIRE CHAIN INSTALLATION AND REMOVAL

CAUTION

Tire chains are only used when extra traction is required and must be used as a four-wheel set. Any other combination may cause damage to the drivetrain.

a. Tire Chain Installation.

(1) Spread out tire chain assembly (1) and line up with tire.

(2) Cautiously move or drive vehicle over tire chain assembly (1) until wheel is positioned at either end of chain assembly (1), allowing tire chain assembly (1) to be draped up and over tire.

(3) Maneuver tire chain assembly (1) until cross-link sections are evenly spaced around tire. Secure one side of tire chain assembly (1) to tire by hooking inside fastener (2) to chain assembly (1). Tighten chain assembly (1) as much as possible.

(4) Repeat steps 1 through 3 until all tire chain assemblies have been properly installed.

(5) Hook end fastener (3) to chain assembly (1) and secure with locking retainer (4) to tighten chain assembly (1). Ensure as many chain links as possible lay between the sidewall head lugs (5) on both sides of tires.

(6) Move vehicle forward a few feet and retighten chain assembly (1) to remove any slack from where tire was resting on chain assembly (1). Secure loose chain linkage to chain assembly (1) with wire or other field expedient method.

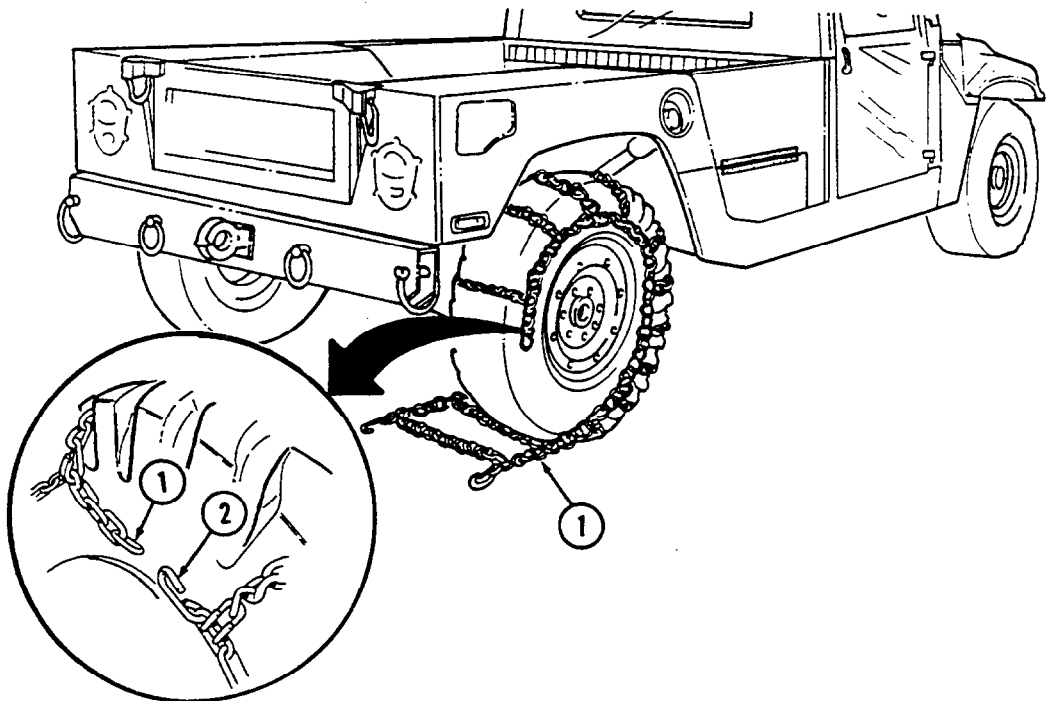

(7) After vehicle is driven one or two miles, stop and retighten tire chains. Ensure as many chain links as possible lie between sidewall head lugs (5) on both sides of tires.

(8) After final tightening, secure loose chain linkage to chain assembly (1) with wire or other field expedient method.

(9) Occasionally check tire chains (1) during operations to ensure tire chains (1) have not slipped.

b. Tire Chain Removal.

CAUTION

Remove tire chains from tires as soon as possible after leaving area requiring their use. Prolonged use of tire chains may damage drivetrain.

(1) Detach locking retainer (4) from end fastener (3) and unhook end fastener (3) from chain assembly (1).

(2) Unhook inside fastener (2) from chain assembly (1) and remove chain assembly (1) from tire.

(3) Drive vehicle off chain assembly (1).

(4) Repeat steps 1 through 3 until all tire chain assemblies (1) have been removed from tires.

(5) Stow tire chain assemblies (1).

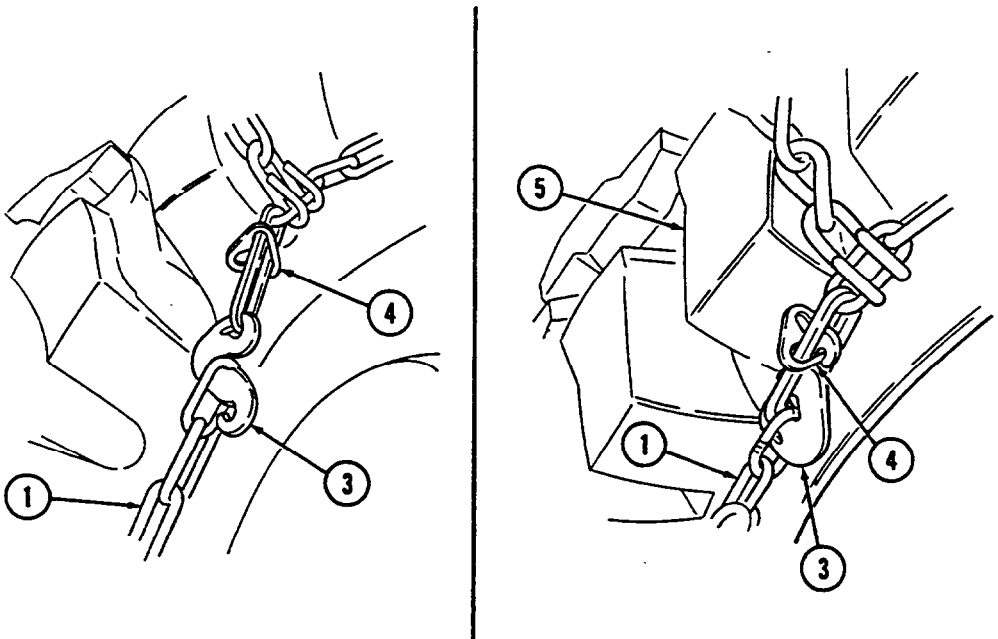

3-23. EMERGENCY FAN CLUTCH OVERRIDE

- a. The radiator fan normally activates when engine temperature exceeds 220°F (104°C) and deactivates when engine temperature drops to 190°F (88°C). If overheating occurs in an emergency situation, this procedure will ensure continuous fan operation.
- b. Raise and secure hood (para. 3-9).
- c. Stop engine (para. 2-14) prior to disconnecting time delay module.
- d. Disconnect time delay module connector (1) from control valve connector (2).
- e. Start engine (para. 2-12).
- f. Check fan for continuous operation. If fan is not operating continuously, stop engine and notify unit maintenance.
- g. Lower and secure hood (para. 3-9).
- h. Allow engine to cool at idle until engine temperature lowers to normal operating temperature of 190°-230°F (88°-110°C).
- i. Proceed to unit maintenance with vehicle. Ensure unit maintenance is notified of emergency service performed on vehicle.

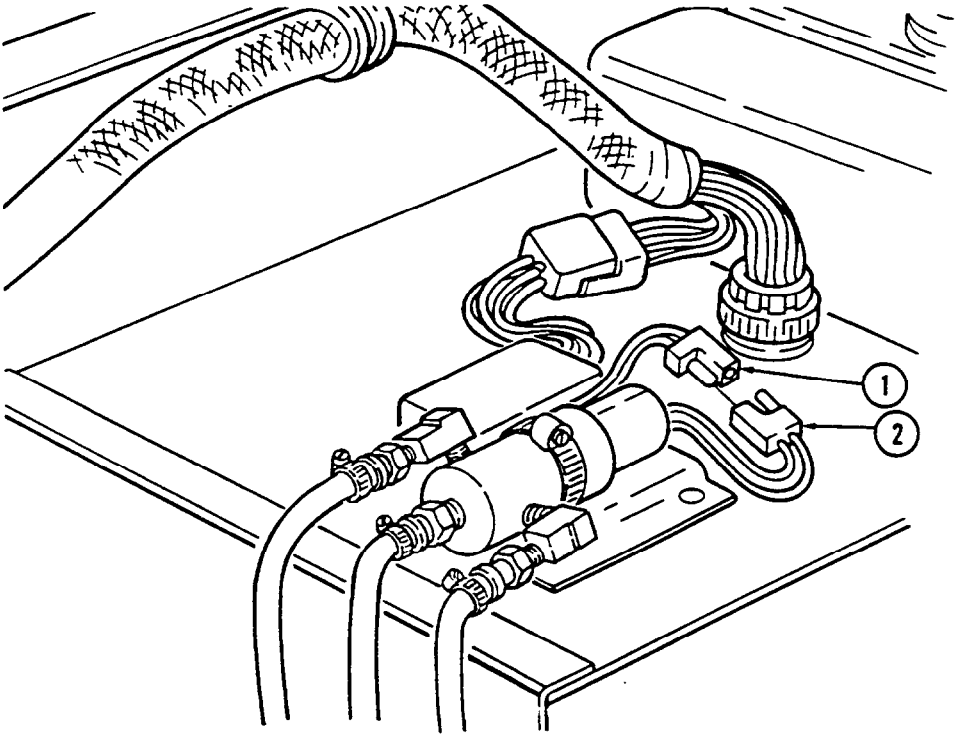

3-24. REARVIEW MIRROR ADJUSTMENT

CAUTION

Visibility from the right mirror may be impaired.

NOTE

Prior to mirror adjustment, move mirror arm assembly until assembly locks in place.

a. Left Mirror (Driver's Side). Loosen top nut (5) and position mirror arm (7) forward of windshield frame (4) so that center line of mirror arm (7) is approximately 9-1/2 in. (24.1 cm) (M1113), 10-1/2 in. (26.7 cm) (M1114) from vehicle (1). Tighten top nut (5). Adjust mirror head (6) for maximum visibility.

b. Right Mirror (Passenger's Side). Loosen top nut (5) and position mirror arm (3) forward of windshield frame (4) so that center line of mirror arm (3) is approximately 7-3/4 in. (19.7 cm) (M1113), 7-1/2 in. (19.1 cm) (M1114) from vehicle (1). Tighten top nut (5). Adjust mirror head (2) for maximum visibility.

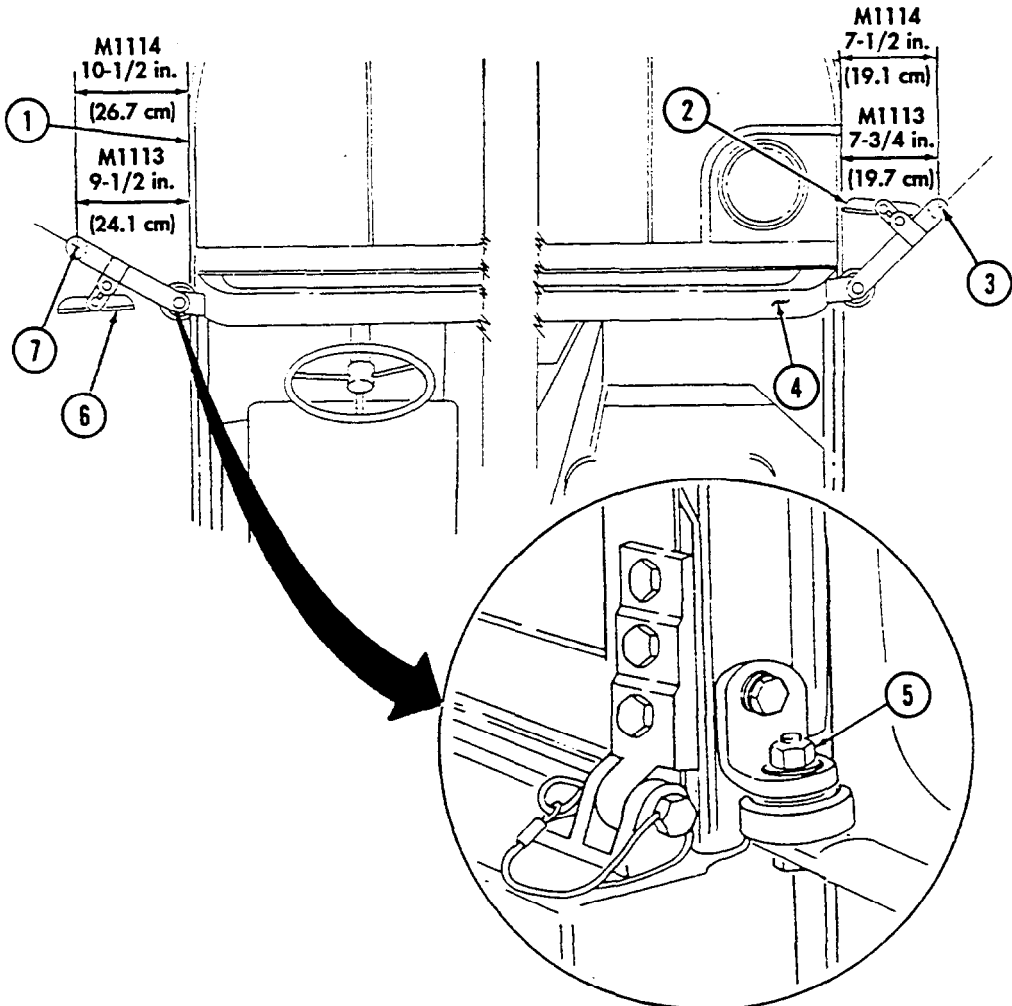

3-25. WHEEL ASSEMBLY REPLACEMENT

a. Wheel Assembly Removal.

WARNING

- Always apply parking brake and block opposite wheel before removing wheel assembly. Avoid removing wheel assembly when vehicle is on sloping terrain. Injury to personnel or damage to equipment may result.
- Remove only the inner group of nuts when removing a wheel from the vehicle. Removing the outer nuts which hold the rim together while the wheel assembly is inflated could result in serious injury or death.
- Ensure scissors jack is positioned directly under lower control arm next to wheel being replaced. Do not place at any other location such as frame rails. Injury to personnel or damage to equipment may result.

(1) Place jack (4) under lower control arm (5) next to wheel being replaced. Center jack (4) squarely under point of contact.

(2) Loosen eight lug nuts (2), but do not remove.

(3) Raise vehicle high enough to allow removal of wheel assembly (1).

(4) Remove eight lug nuts (2) and wheel assembly (1) from geared hub (3).

b. Wheel Assembly Installation.

(1) Install wheel assembly (1) on geared hub (3) and secure with eight lug nuts (2). Tighten lug nuts (2) to full engagement of wheel assembly (1) to geared hub (3).

(2) Slowly lower vehicle and remove jack (4).

(3) Tighten eight lug nuts (2) in sequence indicated.

(4) Notify unit maintenance to tighten lug nuts (2) to proper torque.

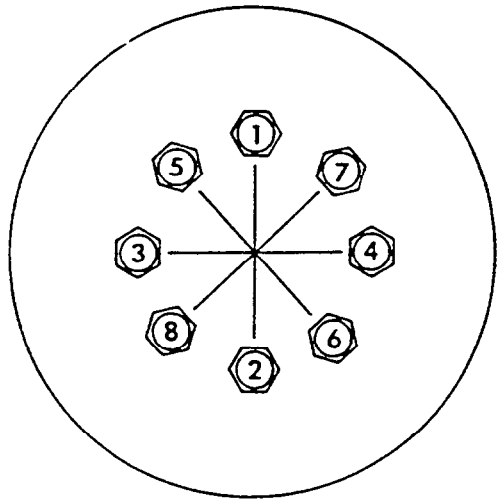
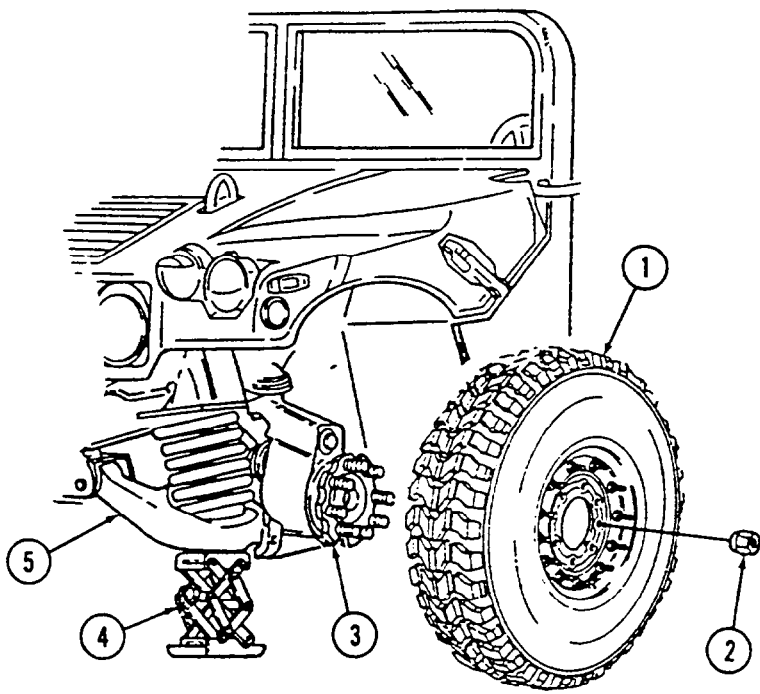

TIGHTENING SEQUENCE

3-26. RADIATOR CLEANING

NOTE

Notify unit maintenance to obtain proper tool to remove socket-head screws.

- a. Remove two socket-head screw and washer assemblies (4) from oil cooler (1) and radiator (6).

WARNING

When raising and securing oil cooler, ensure oil cooler prop rod is secured in oil cooler support bracket. Damage to equipment or injury to personnel may occur if oil cooler is not properly secured in raised position.

- b. Remove oil cooler prop rod (2) from clamp (5), raise oil cooler (1), and securely position oil cooler prop rod (2) in oil cooler support bracket (3).

WARNING

Compressed air used for cleaning purposes will not exceed 30 psi (207 kPa). Use only with effective chip guarding and personal protective equipment (goggles/shield, gloves etc.).

CAUTION

Using high water pressure when cleaning engine, oil cooler, and radiator can cause equipment damage. High water pressure should not be directed on the cooler or radiator.

- c. Using water and compressed air, remove dirt, trash, and insects embedded in oil cooler (1) and radiator (6) fins.

- d. Remove oil cooler prop rod (2) from oil cooler support bracket (3), lower oil cooler (1), and place oil cooler prop rod (2) in clamp (5).

- e. Install oil cooler (1) on radiator (6) with two socket-head screw and washer assemblies (4).

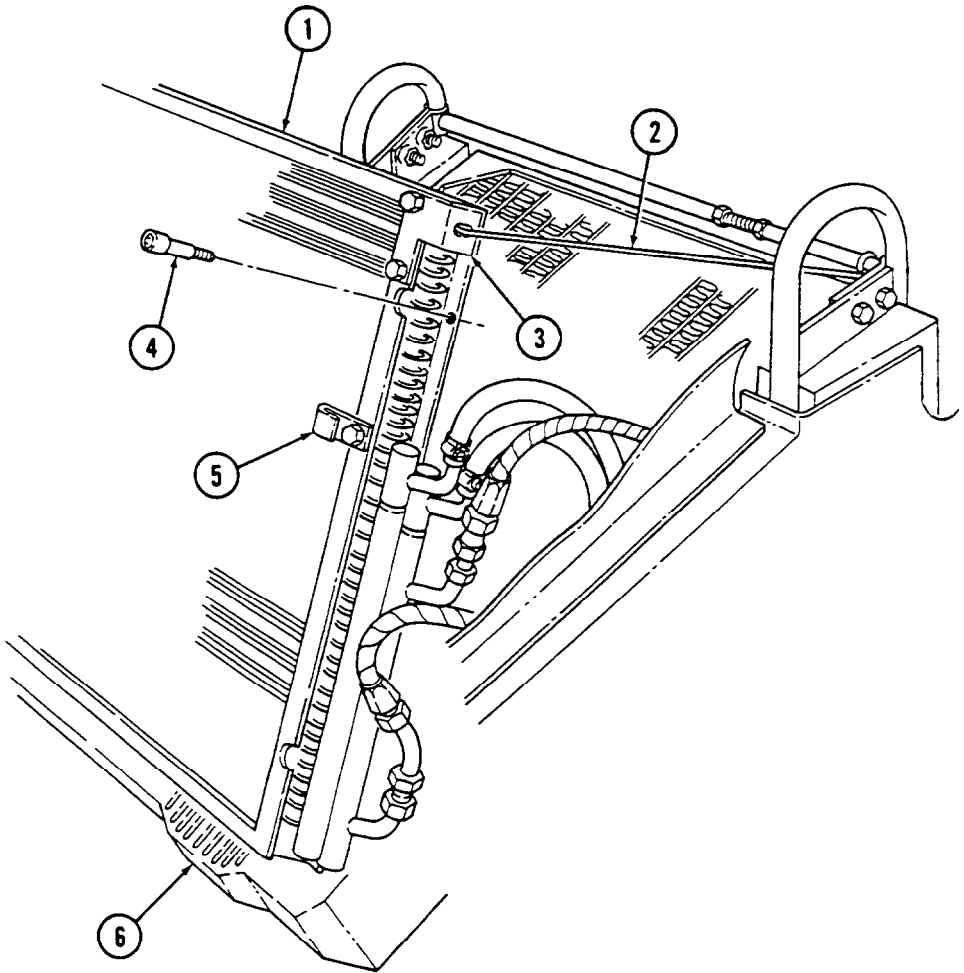

APPENDIX A REFERENCES

A-1. SCOPE

This appendix lists all forms, field manuals, and technical manuals for use with these vehicles.

A-2. DEPARTMENT OF THE ARMY PAMPHLETS

Consolidated Index of Army Publications and Blank Forms. DA Pam 25-30
The Army Maintenance Management System (TAMMS) DA Pam 738-750

A-3. FORMS

Recommended Changes to Publications and Blank Forms. DA Form 2028
Recommended Changes to Equipment Technical
Publications DA Form 2028-2
Hand Receipt/Annex Number DA Form 2062
Exchange Tag DA Form 2402
Equipment Inspection and Maintenance Worksheet DA Form 2404
Maintenance Request DA Form 2407
Preventive Maintenance Schedule and Record. DD Form 314
Product Quality Deficiency Report SF 368

A-4. FIELD MANUALS

NBC Decontamination FM 3-5
Operation and Maintenance of Ordnance Materiel in
Cold Weather (0° to -65°F) FM 9-207
Vehicle Recovery Operations FM 20-22
First Aid for Soldiers FM 21-11
Manual for the Wheeled Vehicle Driver. FM 21-305
Browning Machine Gun, Caliber .50 HB, M2. FM 23-65
Basic Cold Weather Manual. FM 31-70
Northern Operations FM 31-71
Army Motor Transport Units and Operations FM 55-30
Desert Operations. FM 90-3
Jungle Operations. FM 90-5
Mountain Operations FM 90-6

A-5. TECHNICAL MANUALS

- Machine Gun, Caliber .50 Browning, M2 TM 9-1005-213-10
- Materials Used for Cleaning, Preserving, Abrading, and
Cementing Ordnance Materiel and Related Materials
(Including Chemicals) TM 9-247
- Operator's, Unit, Direct Support, and General Support
Maintenance Manual for Care, Maintenance,
Repair, and Inspection of Pneumatic Tires
and Inner Tubes. TM 9-2610-200-14
- Operator's, Unit, Intermediate Direct Support, and
Intermediate General Support Maintenance Manual for
Lead-Acid Storage Batteries. TM 9-6140-200-14

A-6. TECHNICAL BULLETINS

- Security of Tactical-Wheeled Vehicles TB 9-2300-422-20
- Equipment Improvement Report and Maintenance Digest TB 43-0001-39
- Use of Antifreeze Solutions, Antifreeze Extender, and
Cleaning Compounds Test Kit in Engine Cooling Systems TB 750-651

A-7. MISCELLANEOUS PUBLICATIONS

- Hand Receipt TM 9-2320-387-10-HR

A-8. ARMY REGULATIONS

- The Army Integrated Publishing and Printing Program AR 25-30
- Dictionary of United States Army Terms AR 310-25
- Army Materiel Policy and Retail Maintenance Operation AR 750-1
- Army Acquisition Policy AR-70-1
- Prevention of Motor Vehicle Accidents AR 385-55
- Expendable/Durable Items (Except: Medical, Class V,
Repair Parts and Heraldic Items) CTA 50-970

APPENDIX B COMPONENTS OF END ITEM (COEI) AND BASIC ISSUE ITEMS (BII) LISTS

Section I. INTRODUCTION

B-1. SCOPE

This appendix lists components of the end item and basic issue items for the M1113/M1114 vehicles to help you inventory items required for safe and efficient operation of the equipment.

B-2. GENERAL

The Components of End Item (COEI) and Basic Issue Items (BII) lists are divided into the following sections:

a. Section II. Components of End Item (COEI). These items are installed in the vehicle at time of manufacture or rebuild. (None authorized for M1113/M1114 vehicles).

b. Section III. Basic Issue Items (BII). These essential items are required to place M1113/M1114 vehicles in operation, to operate them, and to perform emergency repairs. Although shipped separately packaged, BII must be with the vehicle during operation and whenever it is transferred between property accounts. This list is your authority to request/requisition replacement BII, based on TOE/MTOE authorization of the end item. The illustrations will assist you with hard-to-identify items.

B-3. EXPLANATION OF COLUMNS

The following provides an explanation of columns found in the tabular listings:

a. Column (1) - Illustration Number (Illus Number). This column indicates the number of the illustration in which the item is shown.

b. Column (2) - National Stock Number. Indicates the National Stock Number assigned to the item and will be used for requisitioning purposes.

c. Column (3) - Description. Indicates the Federal item name and, if required, a minimum description to identify the item. The last line for each item indicates the Commercial and Government Entity Code (CAGEC) in parentheses followed by the part number.

d. Column (4) - Unit of Issue (U/I). Indicates how the item is issued for the National Stock Number shown in column two. This unit is expressed by a two-character alphabetical abbreviation; i.e., (ea, pr).

e. Column (5) - Quantity Required (Qty rqr). Indicates the quantity of the item authorized to be used with/on the vehicle.

Section II. COMPONENTS OF END ITEM

These items are installed in the vehicle at the time of manufacture or rebuild.
(None authorized for M1113/M1114 vehicles.)

Section III. BASIC ISSUE ITEMS

(1) Illus Number	(2) National Stock Number	(3) Description CAGEC and Part Number	(4) U/I	(5) Qty rqr
1		TM 9-2320-387-10 [in cotton duck pamphlet bag] TM 9-2320-387-10-HR [in cotton duck pamphlet bag]	EA EA	1 1
2	5110-01-416-7827	AX: single bit, multipurpose, with polyglass handle [in belt loop on back of max tool carrying bag] (OT9K4) 595-010	EA	1
3	5110-01-416-7830	AX SHEATH: multipurpose (covers ax blade) [on ax] (OT9K4) 595-020	EA	1
4	5140-01-429-6945	BAG: jack and tools stowage, cotton duck, 13 in. x 23 in. x 9-1/2 in. (folded) [in footwell area M1113; shell M1114] (19207) 12447043	EA	1
5	2540-00-670-2459	BAG: pamphlet, cotton duck, 3 in. x 9-1/4 in. x 11-1/4 in. (19207) 11676920	EA	1

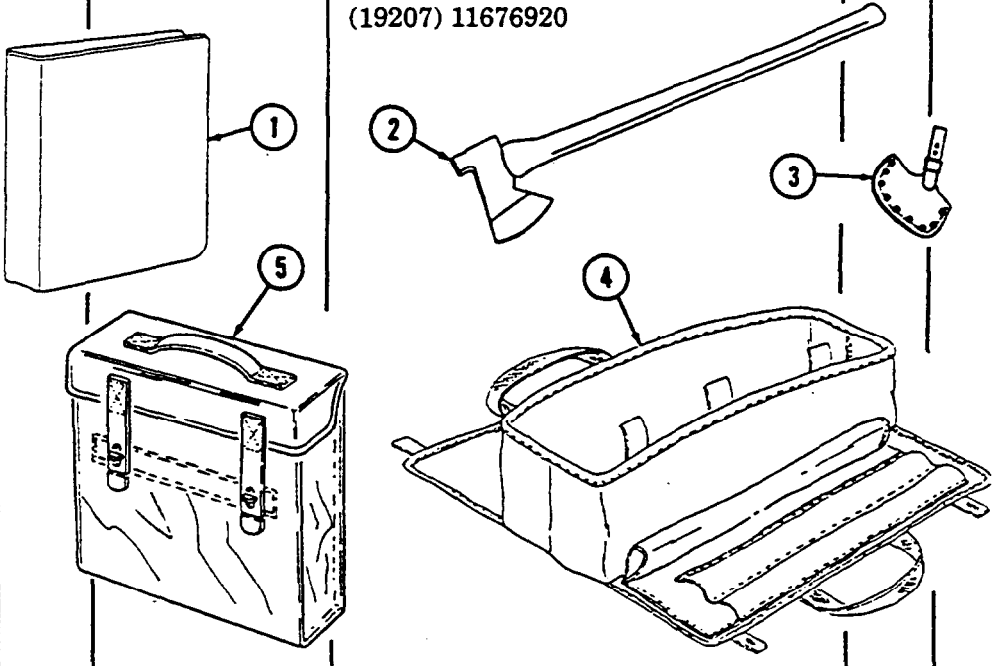

Section III. BASIC ISSUE ITEMS (Cont'd)

(1) Illus Number	(2) National Stock Number	(3) Description CAGEC and Part Number	(4) U/I	(5) Qty rqr
6	5140-00-473-6256	BAG: tool, cotton duck, 10 in. x 20 in., w/flap (19207) 11655979	EA	1
7	5120-01-416-8572	BROAD PICK ATTACHMENT: multipurpose [in max tool carrying bag] (0T9K4) 595-070	EA	1
8	5140-01-416-8569	CARRYING BAG: max tool attachments (0T9K4) 595-030	EA	1
9	5120-01-429-6065	EXTENSION: jack, 15-1/2 in. long [in jack and tools bag] (19207) 12447040	EA	1
10	6545-00-922-1200	FIRST AID KIT: 3 in. x 5-13/16 in. x 8-7/32 in. (19207) 11677011	EA	1

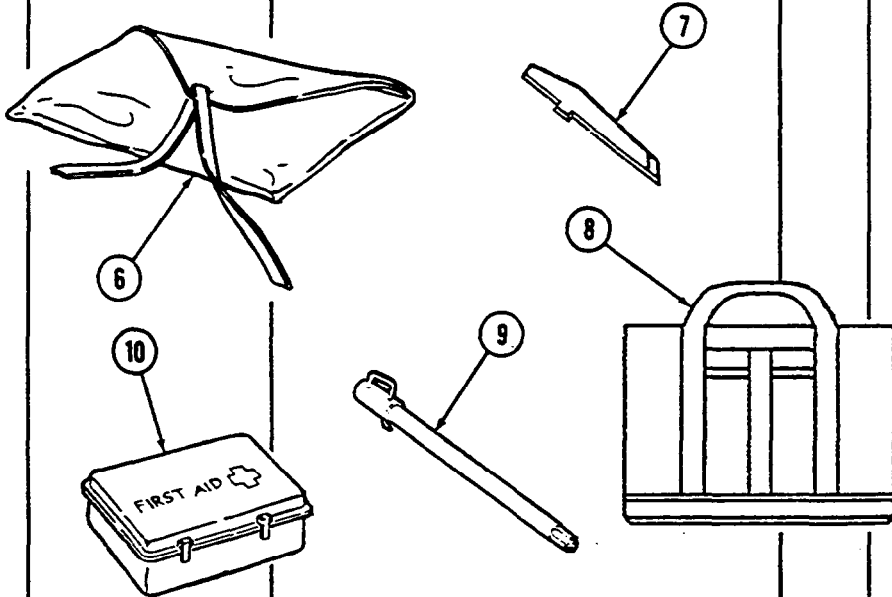

Section III. BASIC ISSUE ITEMS (Cont'd)

(1) Illus Number	(2) National Stock Number	(3) Description CAGEC and Part Number	(4) U/I	(5) Qty req
11	N/A	FIRE EXTINGUISHER: hand, type 1, class 2, 5 lb capacity, w/bracket [on left side of driver's seat] (19207) 12460466	EA	1
12	7510-01-065-0166	FOLDER, EQUIPMENT RECORD: 2-1/2 in. x 8 in. x 10 in. [in pamphlet bag] (72094) 43986-1	EA	1
13	5120-01-429-8137	HANDLE: jack, 18 in. long [in jack and tools bag] (19207) 12447041	EA	1

The image contains three technical drawings. Drawing 11 is a side view of a cylindrical fire extinguisher with a handle on top and a bracket on the left side. Drawing 12 is a perspective view of a folder with a stack of papers inside. Drawing 13 is a side view of a long, thin handle with a curved hook at one end and a threaded section at the other.

Section III. BASIC ISSUE ITEMS (Cont'd)

(1) Illus Number	(2) National Stock Number	(3) Description CAGEC and Part Number	(4) U/I	(5) Qty rqr
14	5120-01-430-3123	JACK: mechanical, scissors, hand, 3.5-ton cap., 6.33 in. closed to 18.70 in. (max) open [in jack and tools bag] (19207) 12447042	EA	1
15	5120-01-416-8571	MATTOCK ATTACHMENT: multipurpose [in max tool carrying bag] (0T9K4) 595-050	EA	1
16	5120-01-416-8573	PICK ATTACHMENT: multipurpose [in max tool carrying bag] (0T9K4) 595-060	EA	1

The image contains three technical drawings. Drawing 14 is a detailed view of a mechanical scissor jack, showing its base, handle, and internal spring mechanism. Drawing 15 is a simple line drawing of a mattock attachment, which is a curved, pointed tool. Drawing 16 is a simple line drawing of a pick attachment, which is a flat, rectangular tool with a pointed end.

Section III. BASIC ISSUE ITEMS (Cont'd)

(1) Illus Number	(2) National Stock Number	(3) Description CAGEC and Part Number	(4) U/I	(5) Qty rqr
17	5120-00-223-7397	PLIERS: combination, slip joint, straight nose w/cutter, 8 in. long, phosphate finish [in tool bag] (19207) 11655775-3	EA	1
18	5120-01-416-8577	RAKE/HOE ATTACHMENT: multipurpose [in max tool carrying bag] (0T9K4) 595-080	EA	1
19	5120-01-416-8574	RAKE/HOE FASTENER: multipurpose [in max tool carrying bag] (0T9K4) 595-090	EA	1

The image contains three technical drawings. Drawing 17 shows a pair of combination pliers with a slip joint and straight nose. Drawing 18 shows a rake/hoe attachment with multiple teeth and a handle. Drawing 19 shows a rake/hoe fastener, which is a small metal component with a hook-like shape.

Section III. BASIC ISSUE ITEMS (Cont'd)

(1) Illus Number	(2) National Stock Number	(3) Description CAGEC and Part Number	(4) U/I	(5) Qty rqr
20	5120-01-416-8575	SAFETY LOCKING PIN: multipurpose [in max tool carrying bag] (OT9K4) 595-999	EA	6
21	5120-00-234-8913	SCREWDRIVER: cross tip, Phillips type, plastic handle, point no. 2, 7-1/2 in. long [in tool bag] (19207) 11655777-12	EA	1
22	5120-00-227-7356	SCREWDRIVER: flat tip, flared sides, plastic handle, round blade, 3/16 in. wide tip, 7-3/4 in. long [in tool bag] (55719) SSDE-66	EA	1
23	5120-01-416-8570	SHOVEL ATTACHMENT: multipurpose [in max tool carrying bag] (OT9K4) 595-040	EA	1

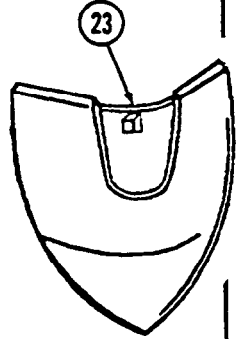
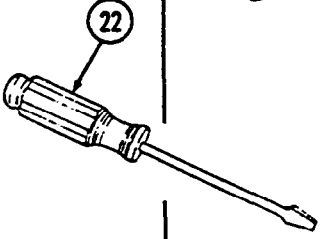
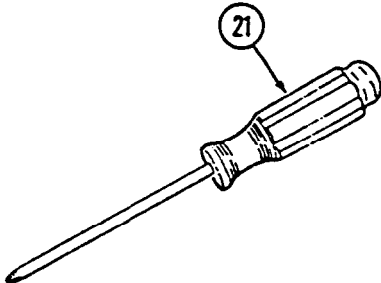

Section III. BASIC ISSUE ITEMS (Cont'd)

(1) Illus Number	(2) National Stock Number	(3) Description CAGEC and Part Number	(4) U/I	(5) Qty req
24	5120-00-240-5328	WRENCH: adjustable, open end, 8 in. long [in tool bag] (96906) MS15461-3	EA	1
25	5120-01-429-6964	WRENCH: ratchet, 5/8 in., 3/4 in. hex socket, 1-1/8 in. [in jack and tools bag] (19207) 12447039	EA	1
26	5120-01-156-7296	WRENCH: wheel lug, 1-15/32 - 1-19/64 in. socket dia., 1-3/16 in. socket depth, 17-1/2 in. long [in jack and tools bag] (11862) 14009303	EA	1

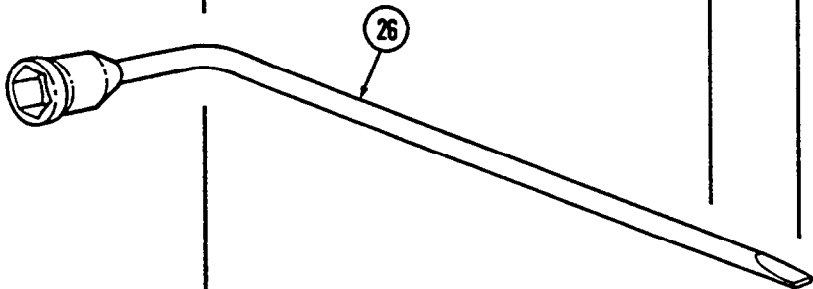
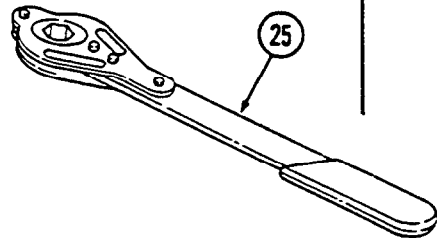
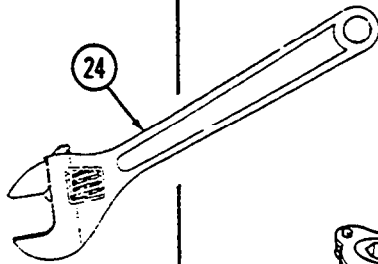

APPENDIX C ADDITIONAL AUTHORIZATION LIST (AAL)

Section I. INTRODUCTION

C-1. SCOPE

This appendix lists additional items authorized for support of M1113/M1114 vehicles.

C-2. GENERAL

This list identifies items that do not have to accompany the vehicle and do not have to be turned in with it. These items are all authorized to you by CTA, MTOE, TDA, or JTA.

C-3. EXPLANATION OF LISTING

National Stock Numbers, descriptions, and quantities are provided to help you identify and request the additional items you require to support the vehicles. The items are listed in alphabetical sequence by item name. If item required differs for different models of this equipment, the model is shown under the "Usable On Code" heading in the description column. These codes are identified as:

Code	Used On
XAA	M1113
XBB	M1114

Section II. ADDITIONAL AUTHORIZATION LIST

(1) NATIONAL STOCK NUMBER	(2) DESCRIPTION		(3) U/I	(4) QTY AUTH
	CAGEC AND PART NUMBER	USABLE ON CODE		
6665-00-935-6955	ALARM: chemical agent, M8 (81361) C5-15-8803		EA	1
2540-00-670-2459	BAG: pamphlet, cotton duck, 3 in. x 9-1/4 in. x 11-1/4 in. (19207) 11676920		EA	1
2510-01-276-9249	BAR: suspension tiedown [in jack and tools bag in footwell area] (34623) 5598373	XAA	EA	2
2540-00-678-3469	BLOCK: chock (96906) MS52127-3		EA	2
3940-00-151-6769	BLOCK: tackle (19207) 11676932		EA	1
2510-01-050-9770	BRACKET: support, decontaminating apparatus (19207) 11644841		EA	1
2590-01-222-7946	CABLE, NATO SLAVE: intervehicular power cable, 12 ft long (19207) 11682379-4		AY	1
7240-01-337-5269	CAN: fuel, steel, MIL type, 5 gal. (81902) MIL-C-53109		EA	2
7240-00-089-3827	CAN: water, military, plastic, 5 gal. (81349) MIL-C-43613		EA	1
2540-01-214-1264	CHAIN: tire, 9/32 side x 1/4 cross link (34623) 5569255		SET	2
4010-00-443-4845	CHAIN: tow, 9/32 side x 12 ft long (19207) 10944642-2		EA	1
4230-01-133-4124	DECONTAMINATING APPARATUS: M-13 (81361) E5-51-527		EA	1
6230-00-163-1856	FLASHLIGHT: 2 x 3-1/2, GFST x 8 in. (82214) 1259		EA	1
4910-00-204-3170	GAUGE: tire pressure (19207) 7081758		EA	1

Section II. ADDITIONAL AUTHORIZATION LIST (Cont'd)

(1) NATIONAL STOCK NUMBER	(2) DESCRIPTION		(3) U/I	(4) QTY AUTH
	CAGEC AND PART NUMBER	USABLE ON CODE		
5120-00-198-5390	KEY, MACHINE: differential fillplug (58536) A-A-2473		EA	1
5315-00-732-1019	KEY, MACHINE: geared hub oil drainplug, straight bar key, 1/2 in. square, 2-1/2 in. long (96906) MS20066-543		EA	1
5340-00-158-3805	PADLOCK SET: (96906) MS35647-10		EA	1
5820-00-223-7473	RADIO SET: 9 x 14 x 16 in. (80058) AN/GRC-160		EA	1
5120-00-222-8852	SCREWDRIVER: flat tip, flared sides, plastic handle, round blade, 1/4 in. wide tip (80063) SCC539502-2		EA	1
7240-00-177-6154	SPOUT: can, gas, flexible with filter screen, 16 in. long (19207) 11677020		EA	1
2510-01-197-8572	TRAY: water can (19207) 12340155	XBB	EA	1
2610-01-333-7632	TIRE: radial, 37 x 12.50R16.5LT (34623) 5935336		EA	1
9905-00-148-9546	TRIANGLES: folding, reflective (81348) RR-W-1817		SET	1
5340-01-277-2460	TURNBUCKLE ASSY: suspension tiedown (34623) 5598406	XAA	EA	2
N/A	WHEEL AND RUNFLAT, RADIAL: (19207) 12460176		EA	1
5120-01-279-4788	WRENCH: open end, 1-1/8 x 18 in. long (34623) 5598407	XAA	EA	1

APPENDIX D EXPENDABLE/DURABLE SUPPLIES AND MATERIALS LIST

Section I. INTRODUCTION

D-1. SCOPE

This appendix lists expendable/durable supplies and materials you will need to operate and maintain the M1113/M1114 vehicles. These items are authorized to you by CTA 50-970, Expendable Items.

D-2. EXPLANATION OF COLUMNS

a. **Column (1) - Item Number.** This number is assigned to each entry in the listing.

b. **Column (2) - Level.** This column identifies the lowest level of maintenance that requires the listed item:

C – Operator/Crew

c. **Column (3) - National Stock Number.** This is the National Stock Number assigned to the item; use it to request or requisition the item.

d. **Column (4) - Description.** Indicates the Federal item name and, if required, a description to identify the item. The last line for each item listing indicates the Commercial and Government Entity Code (CAGEC) in parentheses followed by the part number.

e. **Column (5) - Unit of Measure (U/M).** Indicates the measure used in performing the actual maintenance function. This measure is expressed by an alphabetical abbreviation (QT, GAL.). If the unit of measure differs from the unit of issue, requisition the lowest unit of issue that will satisfy your requirements.

Section II. EXPENDABLE/DURABLE SUPPLIES AND MATERIALS LIST

(1) ITEM NUMBER	(2) LEVEL	(3) NATIONAL STOCK NUMBER	(4) DESCRIPTION	(5) U/M
1	C	8040-01-010-8758	ADHESIVE: silicone rubber (81349) MIL-A-46106 1 Kit	KT
2	C	6850-00-174-1806	ANTIFREEZE: arctic-type (81349) MIL-A-11755 55 Gallon Drum	GAL.
3	C	6850-00-181-7929	ANTIFREEZE: ethylene glycol, inhibited, heavy-duty, single package (81349) MIL-A-46153 1 Gallon Container	GAL.
		6850-00-181-7933	5 Gallon Container	GAL.
4	C	6850-00-926-2275	CLEANING COMPOUND: windshield washer (81348) O-C-1901 1 Pint	PT
5	C	8520-00-262-7177	CREAM CLEANER: plastic, liquid (09177) 200-767-4A 1 Pint Container	PT
6	C	7930-01-107-6997	DETERGENT: general purpose (74188) ORVUS WA PASTE 1 Gallon Container	GAL.
7	C	6810-00-682-6867	DISTILLED WATER: 1 Gallon Container	GAL.
		6810-00-356-4936	5 Gallon Container	GAL.

**Section II. EXPENDABLE/DURABLE SUPPLIES AND
MATERIALS LIST (Cont'd)**

(1) ITEM NUMBER	(2) LEVEL	(3) NATIONAL STOCK NUMBER	(4) DESCRIPTION	(5) U/M
8	C	6850-00-110-4498 6850-00-274-5421 6850-00-285-8011 6850-00-637-6135	DRYCLEANING SOLVENT: (81348) P-D-680, Type II 1 Pint Can 5 Gallon Drum 55 Gallon Drum Bulk	PT GAL. GAL. GAL.
9	C	6550-01-315-5333	ETHANOL/SOLUTION: (66735) F89I244 32 Ounce Bottle	OZ.
10	C	9140-00-286-5296 9140-00-286-5294	FUEL OIL: diesel, regular, DF-2 (81348) VV-F-800 55 Gallon Drum Bulk	GAL. GAL.
11	C	9140-00-286-5288 9140-00-286-5286	FUEL OIL: diesel, winter, DF-1 (81348) VV-F-800 55 Gallon Drum Bulk	GAL. GAL.
12	C	9140-00-286-5284 9140-00-286-5283	FUEL OIL: diesel, arctic, DF-A (81348) VV-F-800 55 Gallon Drum Bulk	GAL. GAL.
13	C	9150-00-935-1017 9150-01-197-7690 9150-01-197-7689	GREASE: automotive and artillery (81349) MIL-G-10924 14 Ounce Cartridge 1-3/4 Pound Can 6-1/2 Pound Can	OZ LB LB

Section II. EXPENDABLE/DURABLE SUPPLIES AND MATERIALS LIST (Cont'd)

(1) ITEM NUMBER	(2) LEVEL	(3) NATIONAL STOCK NUMBER	(4) DESCRIPTION	(5) U/M
14	C	9150-01-015-1542	GREASE: lithium base w/ molybdenum disulfide (60218) LS 2267 14.5 Ounce Cartridge	OZ
15	C	9150-00-530-6814	GREASE: wire-rope, EX (81349) MIL-G-18458 35 Pound Can	LB
16	C	8520-00-082-2146	HAND CLEANER (19410) PAXSOLV16 1 Pound Container	LB
17	C	9150-01-353-4799	HYDRAULIC FLUID: transmission (24617) Dexron® III 1 Quart (plastic) Can	QT
		9150-01-114-9968	55 Gallon Drum	GAL.
18	C	6810-01-075-5546	ISOPROPYL ALCOHOL: (97403) 13222E0694 4 Ounce Bottle	OZ
19	C	9150-00-999-7548	LUBRICANT: interlock (96980) Zipperease 24 Stick Box	OZ
20	C	9150-01-064-6511	LUBRICANT: solid film (F0301) P0329 11 ounce can, aerosol	OZ
21	C	9150-01-035-5390	LUBRICATING OIL: gear, multipurpose, GO 75 (81349) MIL-L-2105 1 Quart Can	QT
		9150-01-035-5391	5 Gallon Drum	GAL.

Section II. EXPENDABLE/DURABLE SUPPLIES AND MATERIALS LIST (Cont'd)

(1) ITEM NUMBER	(2) LEVEL	(3) NATIONAL STOCK NUMBER	(4) DESCRIPTION	(5) U/M
22	C	9150-01-035-5392	LUBRICATING OIL: gear, multipurpose, GO 80/90 (81349) MIL-L-2105 1 Quart Can	QT
		9150-01-035-5393	5 Gallon Drum	GAL.
23	C	9150-00-231-6689	LUBRICATING OIL: general purpose, preservative, PL-S (81348) VV-L-800 1 Quart Can	QT
24	C	9150-00-402-4478	LUBRICATING OIL: internal combustion engine, arctic, OEA (81349) MIL-L-46167 1 Quart Can	QT
		9150-00-402-2372	5 Gallon Drum	GAL.
		9150-00-491-7197	55 Gallon Drum	GAL.
25	C	9150-00-189-6727	LUBRICATING OIL: internal combustion engine, tactical service, OE/HDO 10 (81349) MIL-L-2104 1 Quart Can	QT
		9150-00-186-6668	5 Gallon Drum	GAL.
		9150-00-191-2772	55 Gallon Drum	GAL.
26	C	9150-00-186-6681	LUBRICATING OIL: internal combustion engine, tactical service, OE/HDO 30 (81349) MIL-L-2104 1 Quart Can	QT
		9150-00-188-9858	5 Gallon Drum	GAL.
		9150-00-189-6729	55 Gallon Drum	GAL.

Section II. EXPENDABLE/DURABLE SUPPLIES AND MATERIALS LIST (Cont'd)

(1) ITEM NUMBER	(2) LEVEL	(3) NATIONAL STOCK NUMBER	(4) DESCRIPTION	(5) U/M
27	C		LUBRICATING OIL: internal combustion engine, tactical service, OE/HDO 15/40 (81349) MIL-L-2104	
		9150-01-152-4117	1 Quart Can	QT
		9150-01-152-4118	5 Gallon Drum	GAL.
		9150-01-152-4119	55 Gallon Drum	GAL.
28	C		RAG: wiping, cotton and cotton-synthetic (58536) A-A-531	
		7920-00-205-1711	50 Pound Bale	LB

APPENDIX E STOWAGE AND SIGN GUIDE

E-1. SCOPE

This appendix shows the location for stowage of equipment and material required to be carried on the vehicles.

E-2. GENERAL

The equipment stowage locator is designed to help inventory items required for safe and efficient operation. This equipment locator is representative of BII and applicable AAL stowage on the vehicles. Refer to appendix F for specific deviations from this equipment locator and to para. 2-2 for additional information concerning stowage of equipment.

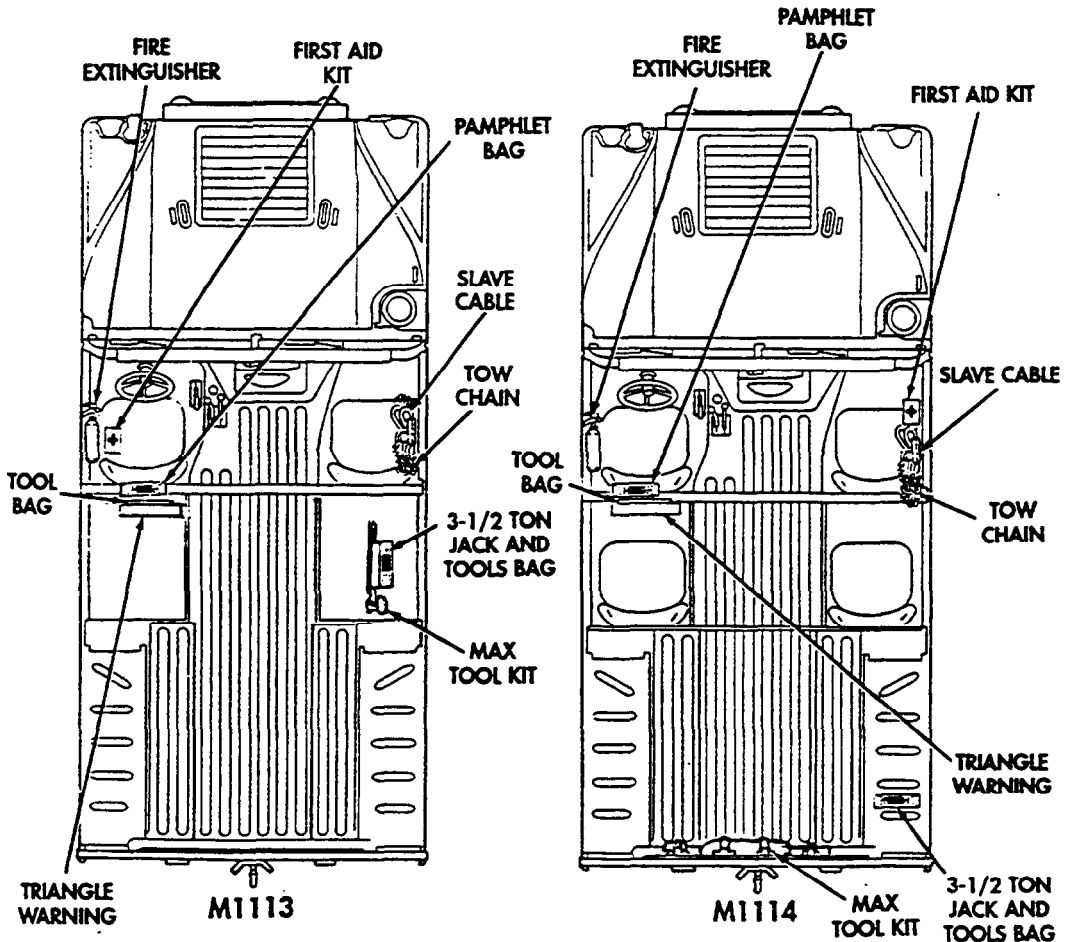

E-3. SIGN GUIDE

LOCATION OF CREW AREA AND EXTERIOR DECALS AND DATA PLATES		
KEY	ITEM	VEHICLE APPLICATION
1	Decal, caution, windshield cleaning	M1114
2	Plate, identification, ignition	Both
3	Decal, instruction, vehicle, break-in service	M1114
4	Plate, instruction, steering wheel lock	Both
5	Decal, speedometer	Both
6	Decal, instruction, vehicle, break-in service	M1113
7	Decal, warning, hand throttle	Both
8	Plate, identification, heater, defroster, temperature, fan	Both
9	Decal, identification, M16A2/M203 rifle, front	M1113
10	Decal, floor heat control	M1114
11	Decal, A/C control	M1114
12	Plate, instruction, heater air control	Both
13	Decal, procedures, tiedown	Both
14	Decal, service and data manuals	Both
15	Plate, instruction, seatbelt retractor (front)	Both
16	Plate, instruction, operating	Both
17	Plate, instruction, driver's seat adjustment	M1113
18	Plate, identification, vehicle	M1113
19	Plate, instruction, driver's seat adjustment	M1114
20	Decal, identification, fire extinguisher	Both
21	Plate, information, deep water fording	Vehicles so equipped
22	Decal, bar code	Both
23	Plate, identification, vehicle	M1114 (under hood)
24	Plate, sling and tiedown/weights and dimensions data	Both
25	Plate, instruction, battery cable connections	M1113
26	Decal, 24V	Both
27	Plate, identification, slave receptacle	Both
28	Plate, instruction, battery cable connections	M1114

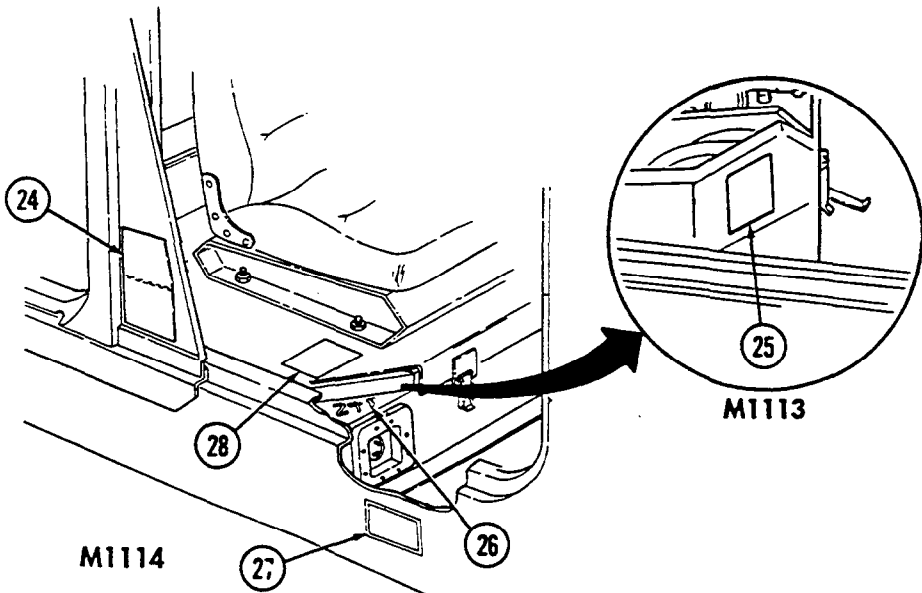
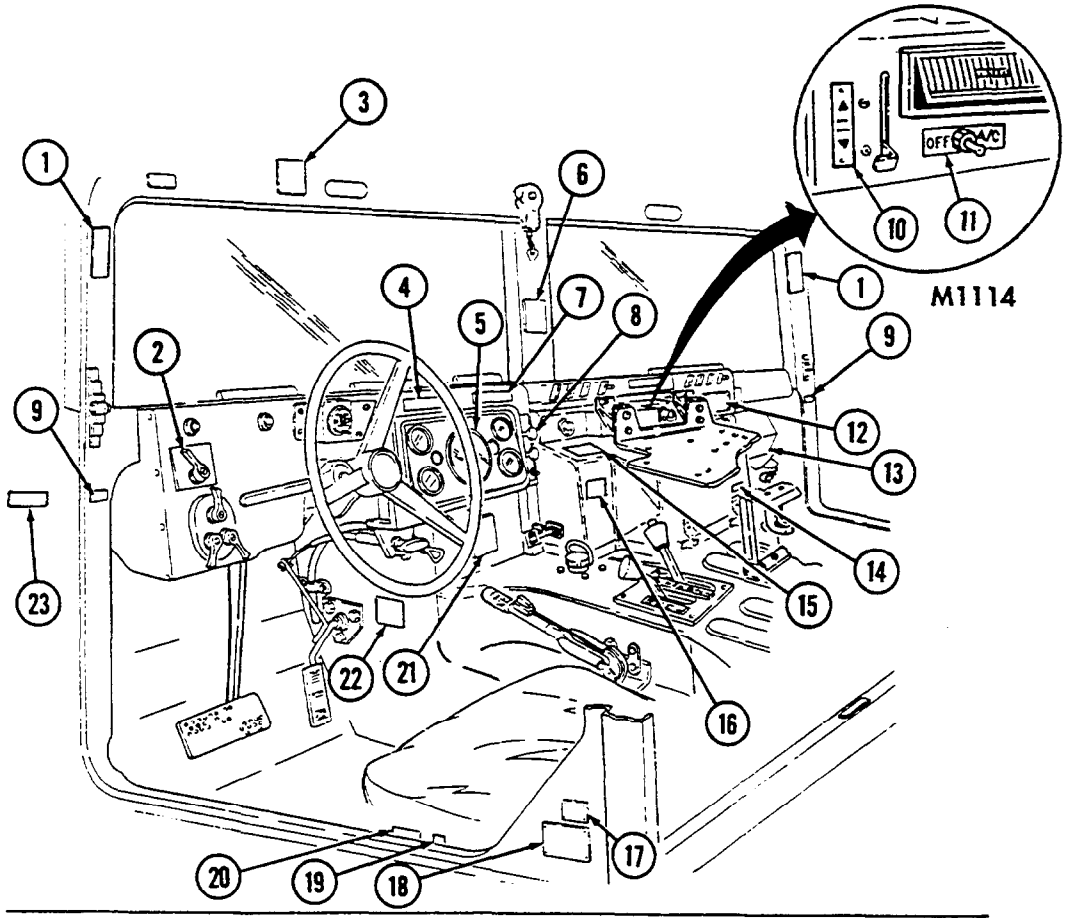

M1114

M1113

E-3. SIGN GUIDE (Cont'd)

LOCATION OF CREW AREA AND EXTERIOR DECALS AND DATA PLATES		
KEY	ITEM	VEHICLE APPLICATION
1	Decal, warning, fan blade	Both
2	Decal, no step	Both
3	Decal, sling	Both
4	Decal, no step	Both
5	Decal, warning, surge tank cap	Both
6	Decal, no step	Both
7	Decal, identification, star	Both
8	Decal, warning, winch	M1114 (when equipped)
9	Decal, identification, sling and tiedown	Both
10	Decal, identification, vehicle number	Both
11	Decal, identification, tiedown	Both
12	Decal, warning, winch	M1113 (when equipped)

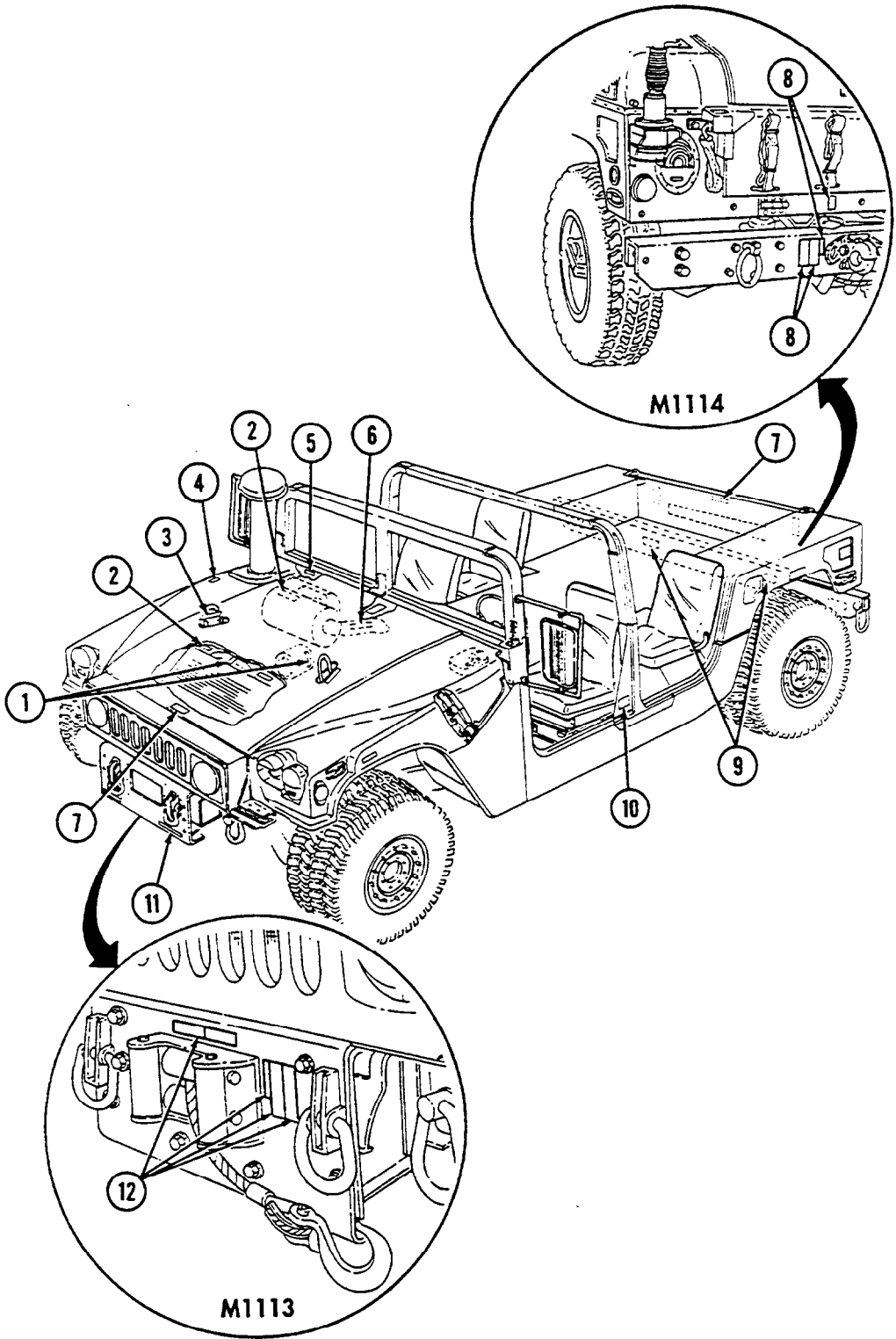

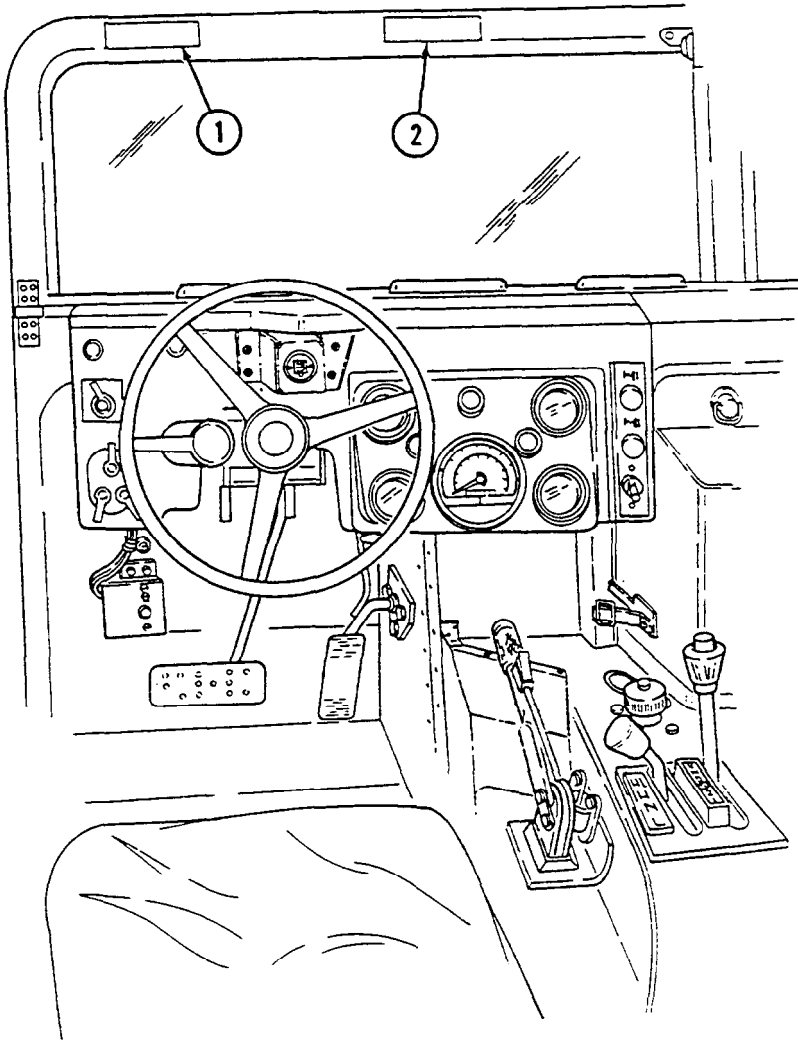

LOCATION OF HEARING PROTECTION DECAL		
KEY	ITEM	VEHICLE APPLICATION
1	Decal, caution, hearing protection	M1114
2	Decal, caution, hearing protection	M1113

APPENDIX F ON-VEHICLE EQUIPMENT LOADING PLANS

F-1. SCOPE

This appendix shows the on-vehicle equipment loading plan for M1113/M1114 vehicles.

Proponent: Commandant
US Army Infantry School
Fort Benning, GA 31905

F-2. M1114 UP-ARMORED CARRIERS W/SUPPLEMENTAL ARMOR LOAD PLAN (MK19/40MM)

This is a standard load plan for the M1114 carriers w/supplemental armor. It includes selected items of personnel and unit equipment issued to most units equipped with this vehicle. Equipment not shown in this document may be loaded in accordance with local command policy.

M1114 UP-ARMORED CARRIERS W/SUPPLEMENTAL ARMOR STOWAGE PLAN (MK19/40MM)

LOAD PLAN	
NO.	ITEM
1	M16A2/M203 Rifle
2	Box Crewman (VIC 1)
3	Binoculars, M17/22
4	Amplifier, 1780 VIC 1
5	Radio (121.3), (VRC-91)
6	M16A2/M203 Rifle
7	Gunner's Platform
8	First Aid Kit
9	Vehicle Power Conditioner
10	Night Vision Goggles, AN/PVS 7B
11	Laser Range Finder, AN/GVS 5 Case
12	Panel, VS17
13	Radiac Meter, AN/VDR
14	Ammunition, 40 mm, MK19 (240 RDS)
15	Chain Saw
16	Ammunition/Tray, M16A2 (1680 RDS)
17	Hand Grenade (24 ea)
18	Ammunition, 40 mm, M203 (72 RDS)
19	3-1/2-Ton Jack
20	Night Vision Sight, AN/PVS 4
21	Radio W/Accessories, Back Pack
22	Tripod, AN/VAS 11
23	Pintle Adapter
24	Machine Gun, M60
25	Max Tool Kit
26	Batteries, AN/VAS 11
27	CE-11 and Spools, TA 312/TA-1
28	Spare Barrel, M60
29	Camouflage Screen and Support System
30	Demolition Kit (2 bags)
31	Claymore Mine, M18A1 (3 ea)
32	Night Vision Sight, AN/TVS 5
33	Water Can
34	Ammunition, 7.62, M60 (800 RDS)
35	Fuel (Diesel) Cans (2 ea)
36	Storage Case, AN/TAS 46

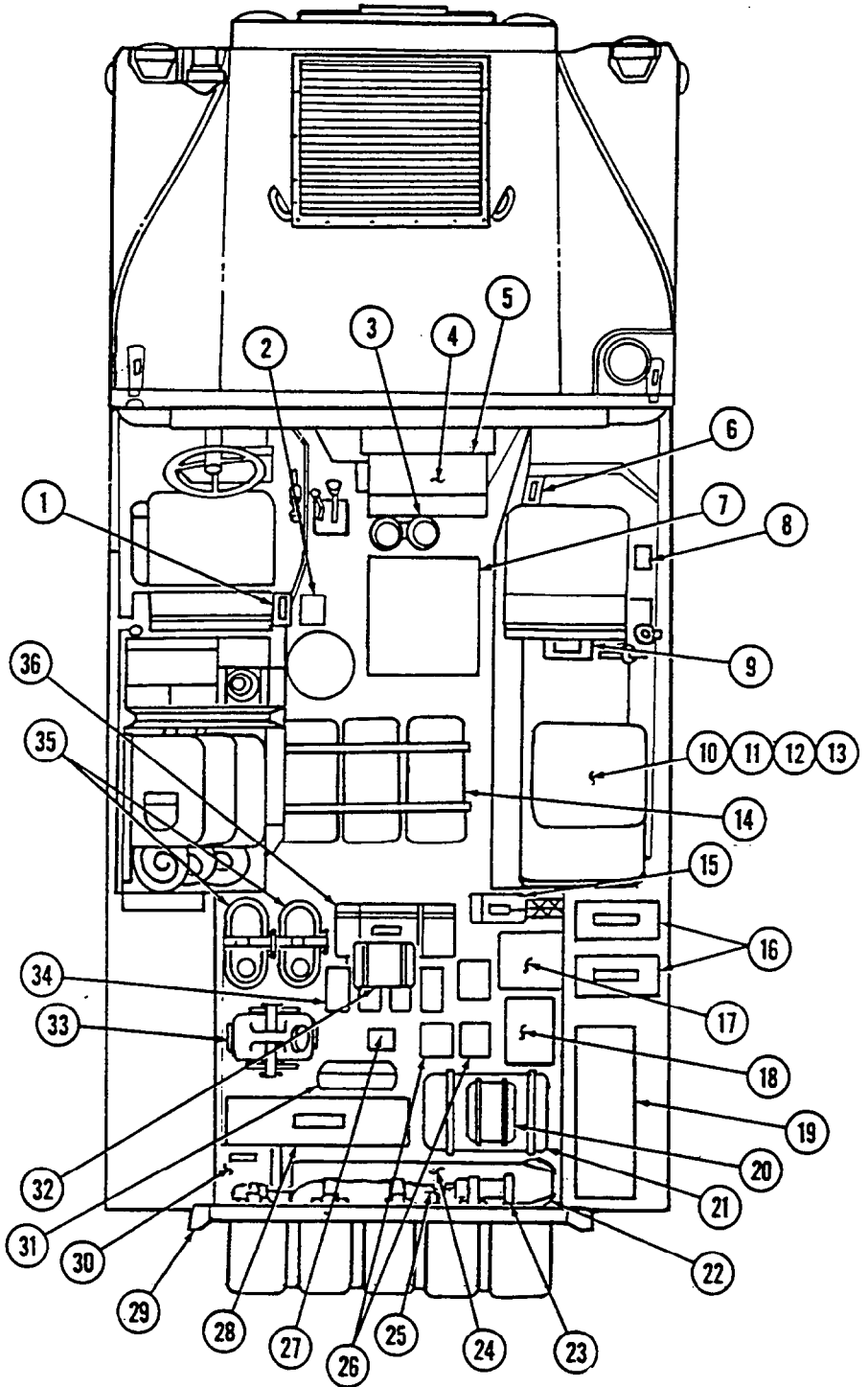

**M1114 UP-ARMORED CARRIERS W/SUPPLEMENTAL
ARMOR STOWAGE PLAN (MK19/40MM) (Cont'd)**

LOAD PLAN	
NO.	ITEM
37	Chemical Detector, M8A1
38	Radiac Charger, PQ1578
39	Total Dose Meter, IM93
40	Radiac Meter, IM 174
41	ALICE Packs (3 ea)
42	Machine Gun Toolbox
43	Wire, Antenna
44	MRE's (2 cases)
45	ICE Storage
46	Warning Triangle and BII Tool Bag
47	Storage Ring, VAS 11
48	Fire Extinguisher
49	Decontaminating Bottle, M-13
50	MK19 W/Ammunition (48 RDS)
51	Tripod, AN/VAS 11
52	Laser Range Finder, AN/VAS 5
53	Duffle Bags (3 ea)
54	Antitank Missile (AT-4), (under cargo hatch)
55	Hatch Stowage Net
56	Switch and Cable, Remote, Winch
57	Stowage Compartment Net

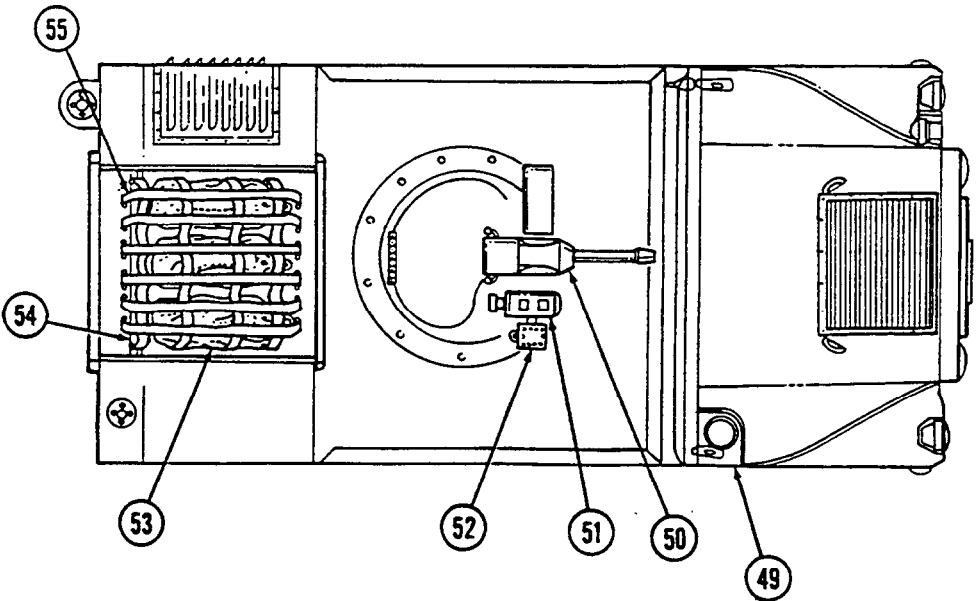
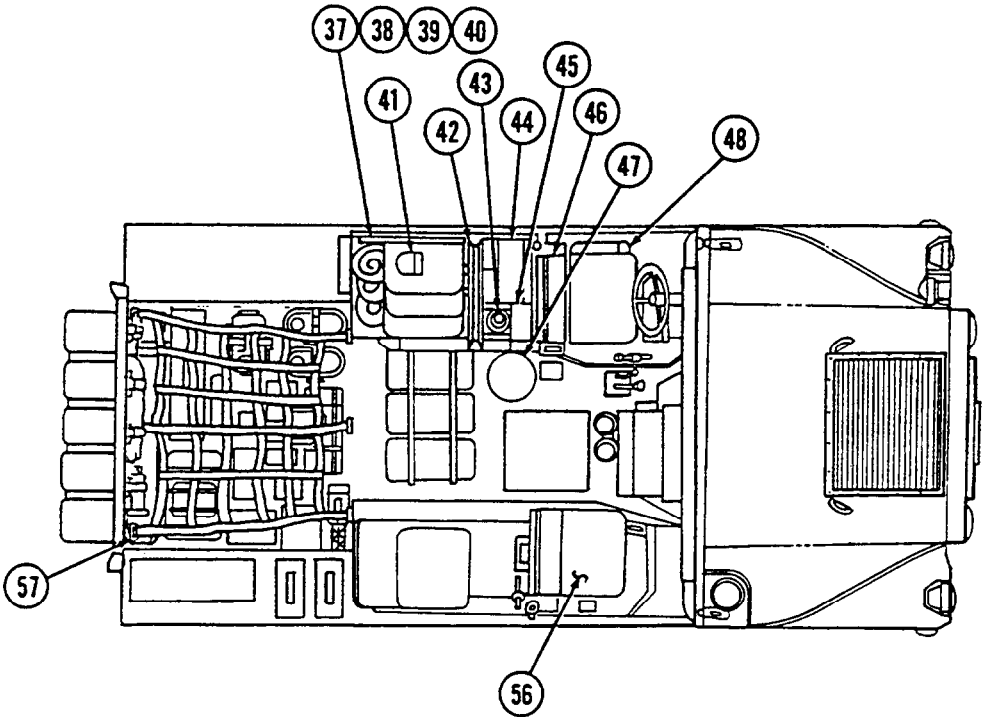

F-3. M1114 UP-ARMORED CARRIERS W/SUPPLEMENTAL ARMOR LOAD PLAN (M2/.50 CAL)

This is a standard load plan for the M1114 carriers w/supplemental armor. It includes selected items of personnel and unit equipment issued to most units equipped with this vehicle. Equipment not shown in this document may be loaded in accordance with local command policy.

M1114 UP-ARMORED CARRIERS W/SUPPLEMENTAL ARMOR STOWAGE PLAN (M2/.50 CAL)

LOAD PLAN	
NO.	ITEM
1	M16A2/M203 Rifle
2	Box, Crewman (VIC 1)
3	Binoculars, M17/22
4	Amplifier, 1780 VIC 1
5	Radio (121.3), (VRC-91)
6	M16A2/M203 Rifle
7	Gunner's Platform
8	First Aid Kit
9	Night Vision Goggles, AN/PVS 7B
10	Laser Range Finder, AN/GVS 5, Case
11	Panel, VS17
12	Radiac Meter, AN/VDR
13	Chain Saw
14	Hand Grenade (24 ea)
15	Mine Detector, AN/PSS 11
16	Ammunition, .40 mm, M203 (72 RDS)
17	Radio W/Accessories, Back Pack
18	Night Vision Sight, AN/PVS 4
19	Pintle Adapter
20	Batteries, AN/TAS 4
21	CE-II and Spools, TA-1/TA 312
22	Machine Gun, M60
23	Max Tool Kit
24	Camouflage Screen and Support System
25	Demolition Kit (2 bags)
26	Space Barrel, M60/M2
27	Claymore Mine, M18A1 (3 ea)
28	Water Can
29	Machine Gun Ammunition, M60 (800 RDS)
30	Fuel (Diesel) Cans (2 ea)
31	Night Vision Sight, AN/TVS 5
32	Storage Case, AN/TVS 4/6

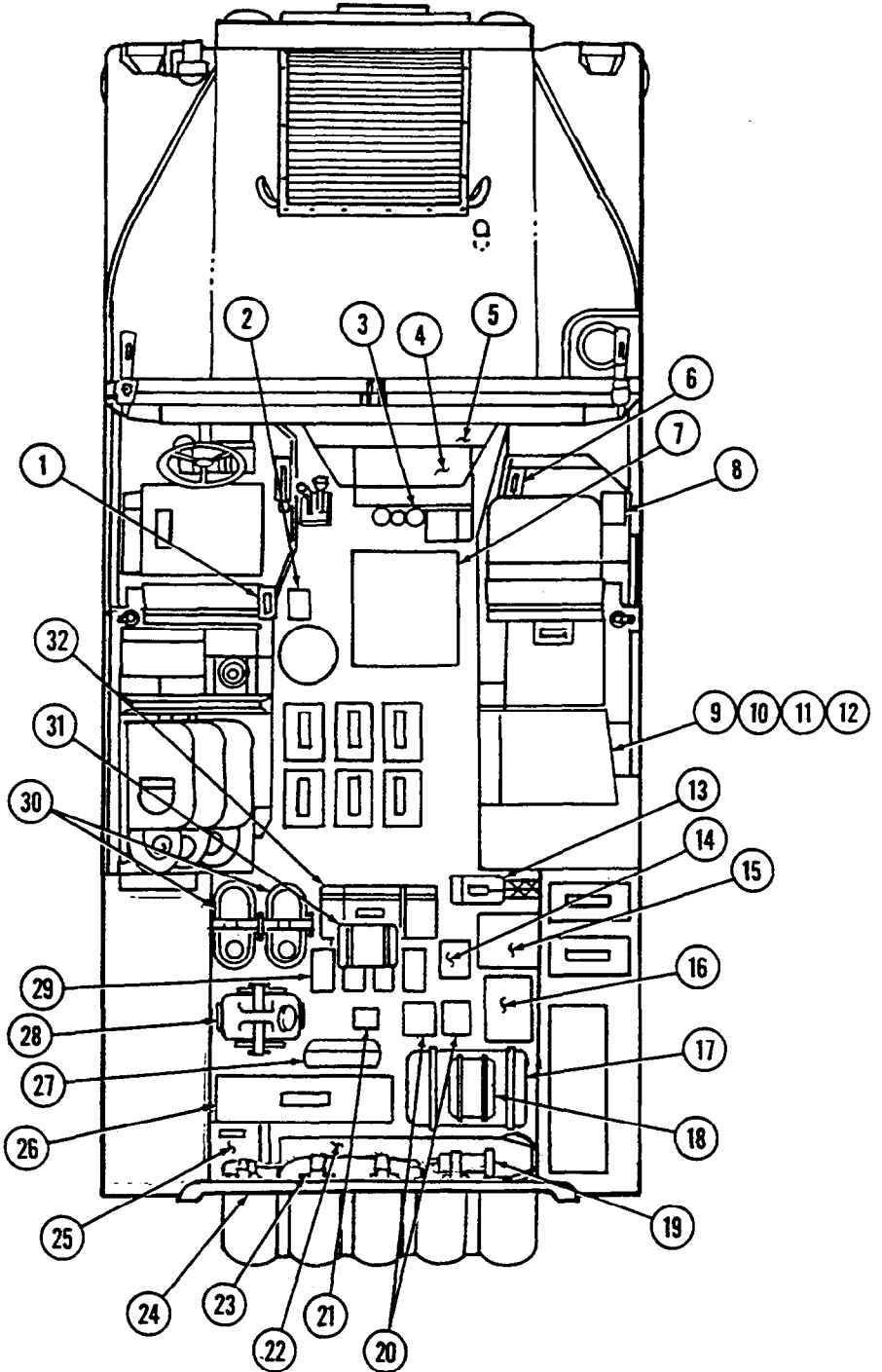

**M1114 UP-ARMORED CARRIERS W/SUPPLEMENTAL
ARMOR STOWAGE PLAN (M2/.50 CAL) (Cont'd)**

LOAD PLAN	
NO.	ITEM
33	Chemical Detector, M8A1
34	Radiac Charger, PQ 1578
35	Total Dose Meter, IM93
36	Radiac Meter, IM 174
37	ALICE Packs (3 ea)
38	Machine Gun Toolbox
39	Wire, Antenna
40	MRE's (2 Cases)
41	ICE Storage
42	Warning Triangle and BII Tool Bag
43	Storage Ring, VAS 11
44	Fire Extinguisher
45	Decontaminating Bottle, M-13
46	M2 .50 Cal, Machine Gun
47	Tripod, AN/VAS 11
48	Long Range Finder, AN/GVS 5
49	Duffle Bags (3 ea)
50	Antitank Missile (AT-4), (under cargo hatch)
51	Hatch Stowage Net
52	Switch and Cable, Remote, Winch
53	Vehicle Power Conditioner
54	Ammunition, M2, .50 Cal. (700 RDS)
55	Ammunition/Tray, 556 M16A2 (1680 RDS)
56	3-1/2-Ton Jack
57	Stowage Compartment Net

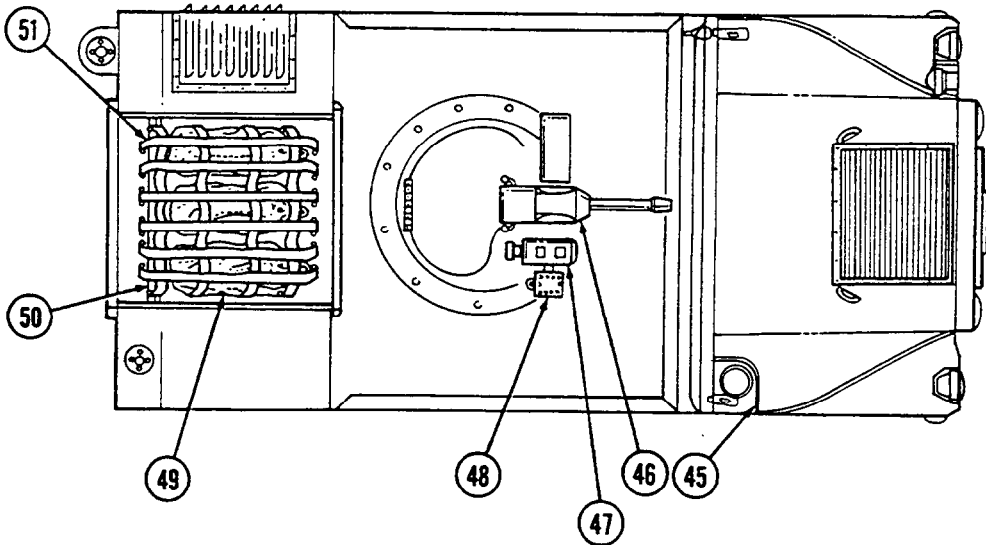
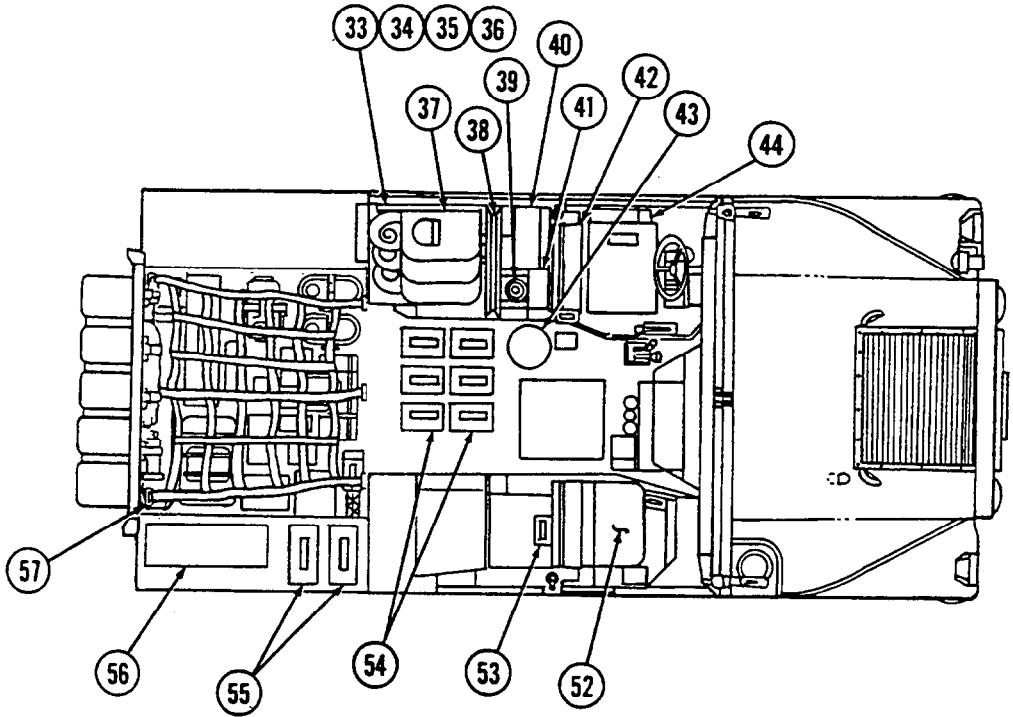

F-4. M1113 LOAD PLAN

This is a standard load plan for the M1113 vehicle. It is designed to supplement the stowage and sign guide contained in appendix E. It includes selected items of personnel and unit equipment issued to most units within the Army for this vehicle. Equipment not shown in this document may be loaded in accordance with local command policy.

M1113 STOWAGE PLAN

LOAD PLAN	
NO.	ITEM
1	M16A2/M203 Rifle
2	M16A2/M203 Rifle
3	Radio, AN/GRC-121.3
4	Singars (AV/VRC-89, AN/VRC-91 or AN/VRC-92)
5	Chain, Tow
6	Cable, NATO-Slave
7	Switch and Cable, Remote, Winch
8	Jack and Tools Bag, 3-1/2-Ton
9	Max Tool Kit
10	Decontaminating Bottle, M-13
11	Warning Triangle
12	Tool Kit
13	Fire Extinguisher
14	First Aid Kit (under driver seat)

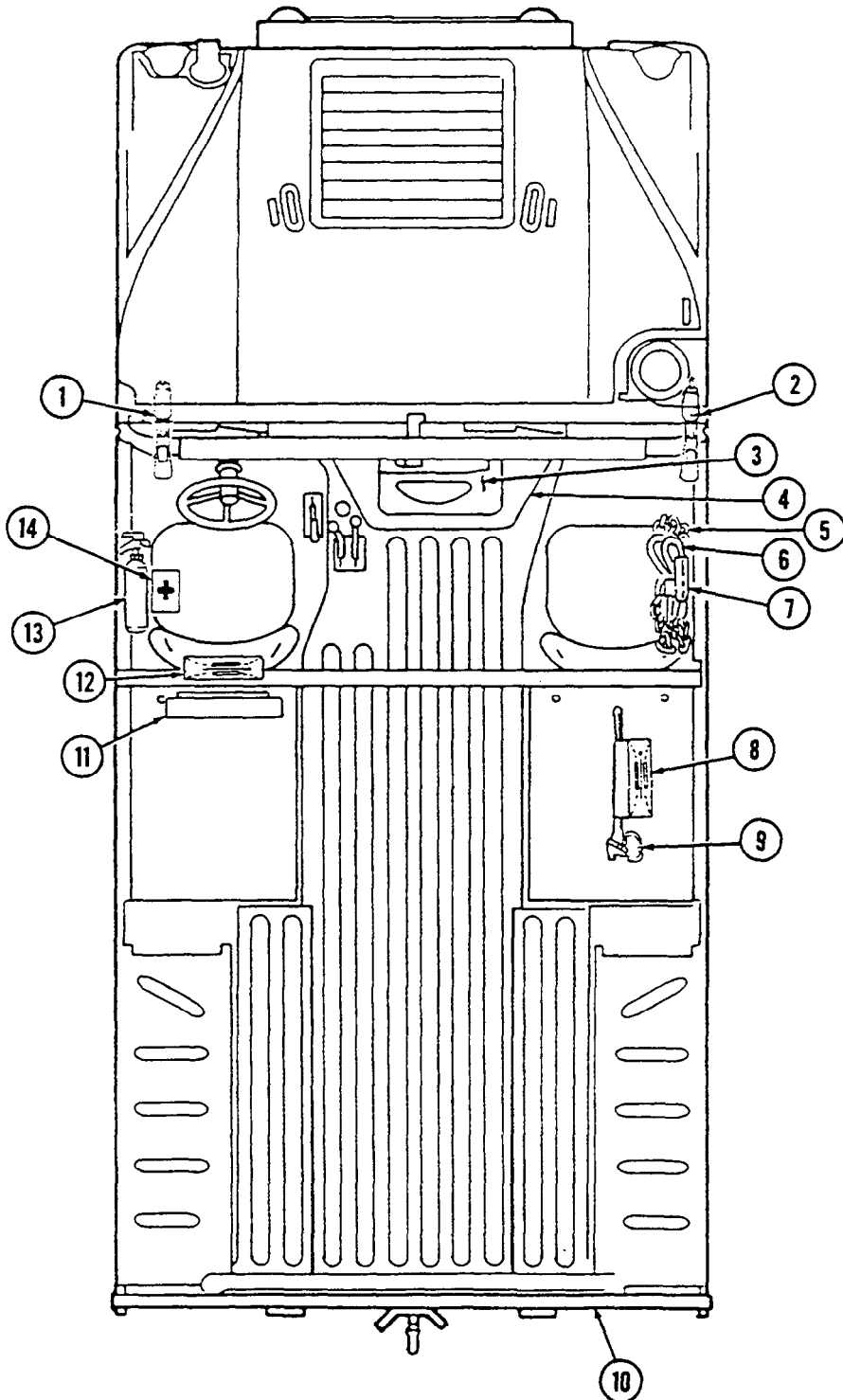

APPENDIX G LUBRICATION INSTRUCTIONS

G-1. SCOPE

This appendix gives lubrication requirements for the M1113/M1114 vehicles which are the responsibility of the operator/crew.

G-2. GENERAL LUBRICATION REQUIREMENTS

a. Maintaining Lubricant Levels. Lubricant levels must be checked as specified in the PMCS (chapter 2, section 2) and table G-1, Lubrication. Steps must be taken to replenish and maintain lubricant levels.

WARNING

- Drycleaning solvent P-D-680 is TOXIC and flammable. Wear protective goggles and gloves, use only in well-ventilated area, avoid contact with skin, eyes, and clothes, and do not breathe vapors. Keep away from heat and flame. Never smoke when using solvent. The flashpoint for type I drycleaning solvent is 100°F (38°C), and for type II, is 138°F (59°C). Failure to comply may result in injury or death to personnel.
- If personnel become dizzy while using cleaning solvent, immediately get fresh air and medical help. If solvent contacts skin or clothes, flush with cold water. If solvent contacts eyes, immediately flush eyes with water and get medical attention.

b. Cleaning Fittings Before Lubrication. Clean parts with drycleaning solvent P-D-680 or equivalent. Dry before lubricating.

NOTE

Dotted arrow points indicate lubrication on both sides of the equipment.

c. Lubrication After Fording. Following fording operation, lubricate all fittings below fording depth and check submerged gear boxes for presence of water.

d. Lubrication After High-Pressure Washing. After a thorough washing, lubricate all grease fittings and oil can points outside and underneath vehicle.

e. Localized Views. A reference to the appropriate localized view is given after most lubrication entries. Localized views begin on page G-11.

G-3. LUBRICATION INTERVALS

a. Service Interval Under Normal Conditions. Service intervals listed are for normal operation in moderate temperatures, humidity, and atmospheric conditions. Hard-time intervals may be shortened if your lubricants are contaminated or if you are operating the equipment under adverse conditions, including longer-than-usual operating hours. Hard-time intervals may be extended during periods of low activity, though adequate preservation precautions must be taken. Perform semiannual service intervals every six months, or 3,000 miles (4,827 km), whichever comes first.

b. Service Interval Under Unusual Conditions. Increase frequency of lubricating service when operating under abnormal conditions such as high or low temperatures, prolonged high-speed driving, or extended cross-country operations. Such operation can diminish lubricant's protective qualities. More frequent lubricating service intervals are necessary to maintain vehicle readiness when operating under abnormal conditions.

c. Hard-Time Intervals. Intervals shown in this appendix are based on mileage and calendar times. An example of mileage and calendar interval is: 3/S, in which 3 stands for 3,000 mi (4,827 km), and S stands for semiannually (every six months). The lubrication of the vehicle is to be performed at whichever interval occurs first. For equipment under manufacturer's warranty, hard-time oil service intervals shall be followed.

G-4. LUBRICATION FOR OPERATION UNDER EXTREME TEMPERATURES

a. Changes in Lubricant Grades. Lubricant grades change with weather conditions. Refer to lubrication table for lubricant grade changes.

b. Arctic Conditions. Refer to FM 9-207, Operation and Maintenance of Ordnance Materiel in Cold Weather (0°F to -65°F) (-18°C to -54°C), or the lubrication table.

G-5. CORROSION CONTROL

Refer to para. 2-4 for appropriate corrosion control procedures.

Table G-1. Lubrication.

USAGE	FLUID/LUBRICANT	CAPACITIES	EXPECTED TEMPERATURES
Engine Oil (MIL-L-2104) (MIL-L-46167)	OE/HDO 30 OE/HDO 10 OEA	Crankcase: w/o filter 7 qt (6.6 L) w/ filter 8 qt (7.6 L) Dry System 10 qt (9.5 L)	Above +15° F (-9° C) +40° to -15° F (+4° to -26° C) +40° to -65° F (+4° to -54° C)
Engine Coolant	Ethylene Glycol and Water 1/4 Ethylene Glycol, 3/4 Water 2/5 Ethylene Glycol, 3/5 Water 3/5 Ethylene Glycol, 2/5 Water	Radiator: 5 qt (4.7 L) Complete System: 26 qt (24.6 L)	Above +15° F (-9° C) +40° to -15° F (+4° to -26° C) +40° to -65° F (+4° to -54° C)
Transmission	Dexron® III	Dry 13.5 qt (12.8 L) Drain & Refill 7.7 qt (7.3 L)	All Temperatures
Steering System	Dexron® III	1 qt (0.95 L) w/Cooler 1.25 qt (1.18 L)	All Temperatures
Ball Joints, Tie Rod Ends, Pitman Arm, Propeller Shafts, etc.	GAA (MIL-G-10924)	As Required	All Temperatures
Hinges, Cables, and Linkages	OE/HDO	As Required	All Temperatures

OE/HDO 15/40 (Grade 15W-40) lubricant may be used when expected temperatures are above +5°F (-15°C). If OEA lubricant is required to meet the temperature ranges prescribed in the lubrication table, then the OEA lubricant is to be used in place of OE/HDO 10 lubricant for all temperature ranges. If operating conditions are severe or abnormal, service chassis lubrication points at 1,000 mi (1,609 km).

Table G-1. Lubrication (Cont'd).

USAGE	FLUID/LUBRICANT	CAPACITIES	EXPECTED TEMPERATURES
Door Latches and Wire Handle Lock	PL-S (VV-L-800)	As Required	All Temperatures
Wire Rope (if winch is used frequently)	OE/HDO 30 (MIL-L-2104)	As Required	Above +80° F (+27° C) to -30° F (-34° C)
(if winch is used infrequently)	EX (MIL-G-18458)	As Required	Above +80° F (+27° C) to -30° F (-34° C)
(arctic condition)	GO 75 (MIL-L-2105)	As Required	-30° to -65° F (-34° to -54° C)
<p>FUEL REQUIREMENTS — TEMPERATURE LIMITS (VV-F-800)</p> <p>Grade DF2 Fuel For use above +10°F (-12°C)*</p> <p>Grade DF1** For use below +10°F (-12°C) to above -20°F (-29°C)</p> <p>Grade DFA For use below -20°F (-29°C)</p> <p>* Temperature limits may vary, dependent on the cloud point of the actual DF2 fuel being supplied in the geographical area.</p> <p>** DF1 is not normally procured in CONUS or OCONUS. Refineries will blend DF2 with kerosene to meet temperature requirements of DF1.</p>			

LUBRICATION POINTS

INTERVAL • LUBRICANT

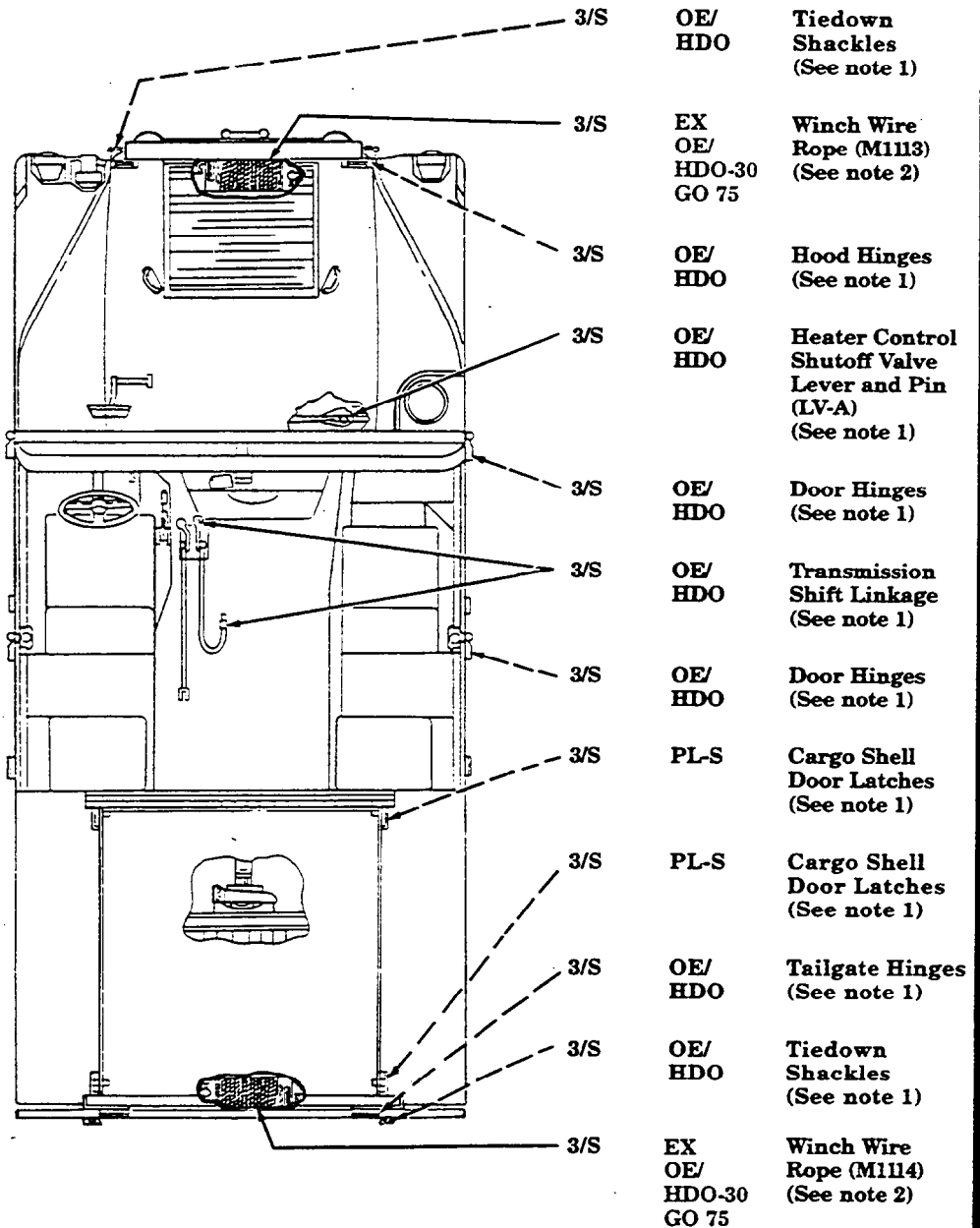

NOTE

A REFERENCE TO THE LOCALIZED VIEW (LV) IS PROVIDED AFTER LUBRICATION POINT ENTRY, WHERE APPLICABLE.

LUBRICATION POINTS (Cont'd)

LUBRICANT • INTERVAL

- | | | |
|--|------------|-----|
| Accelerator Linkage (LV-C)
(See note 1) | OE/
HDO | 3/S |
| Heater Control Knob and Plunger (LV-B)
(See note 1) | OE/
HDO | 3/S |
| Transfer Case Shift Linkage
(See note 1) | OE/
HDO | 3/S |
| Door Handles
(See note 1) | OE/
HDO | 3/S |
| Cargo Shell Door Rear Wire Handle Lock
(See note 1) | PL-S | 3/S |

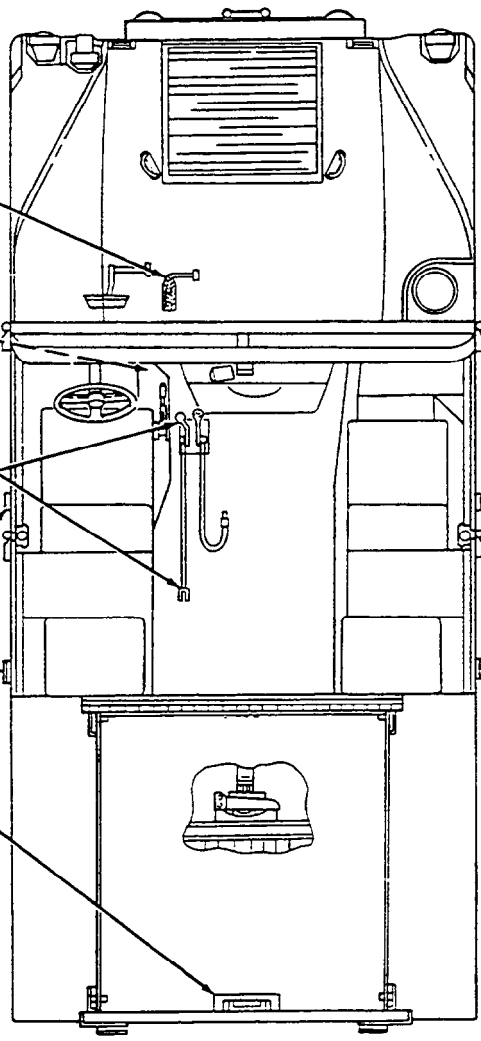

NOTE

A REFERENCE TO THE LOCALIZED VIEW (LV) IS PROVIDED AFTER LUBRICATION POINT ENTRY, WHERE APPLICABLE.

LUBRICATION POINTS (Cont'd)

INTERVAL • LUBRICANT

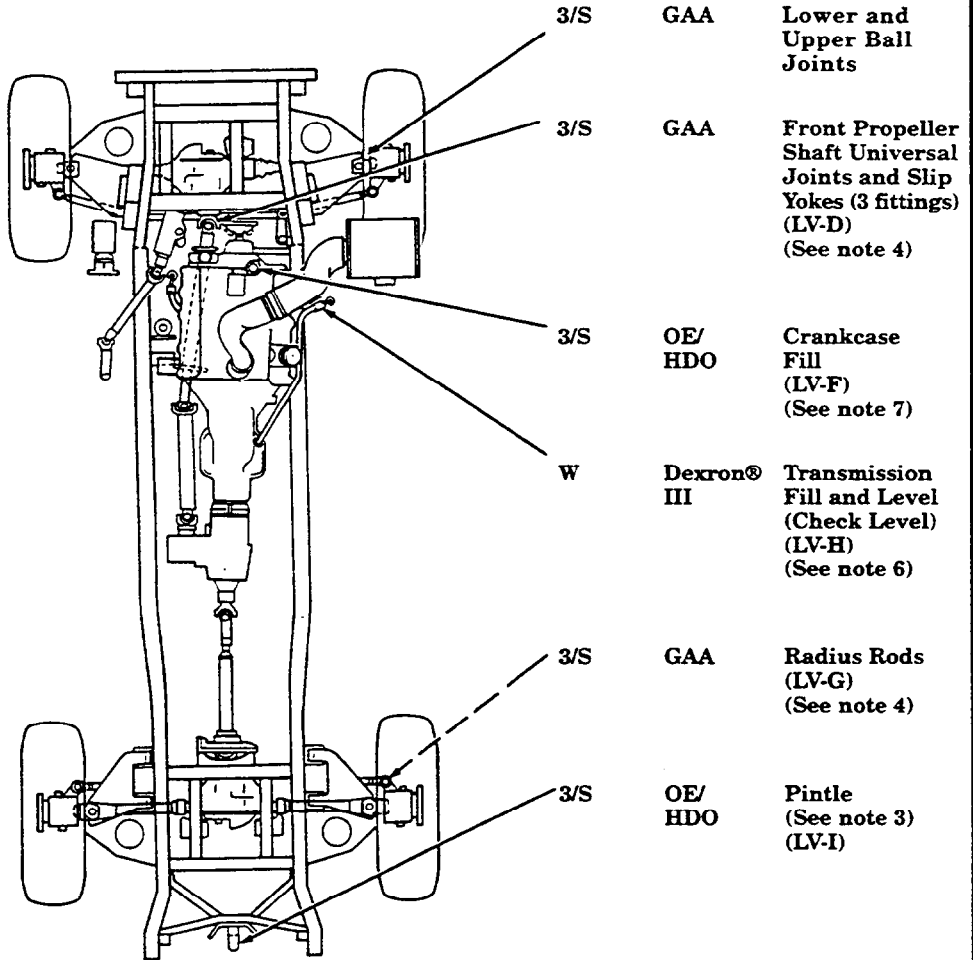

NOTE

A REFERENCE TO THE LOCALIZED VIEW (LV) IS PROVIDED AFTER LUBRICATION POINT ENTRY, WHERE APPLICABLE

LUBRICATION POINTS (Cont'd)

LUBRICANT • INTERVAL

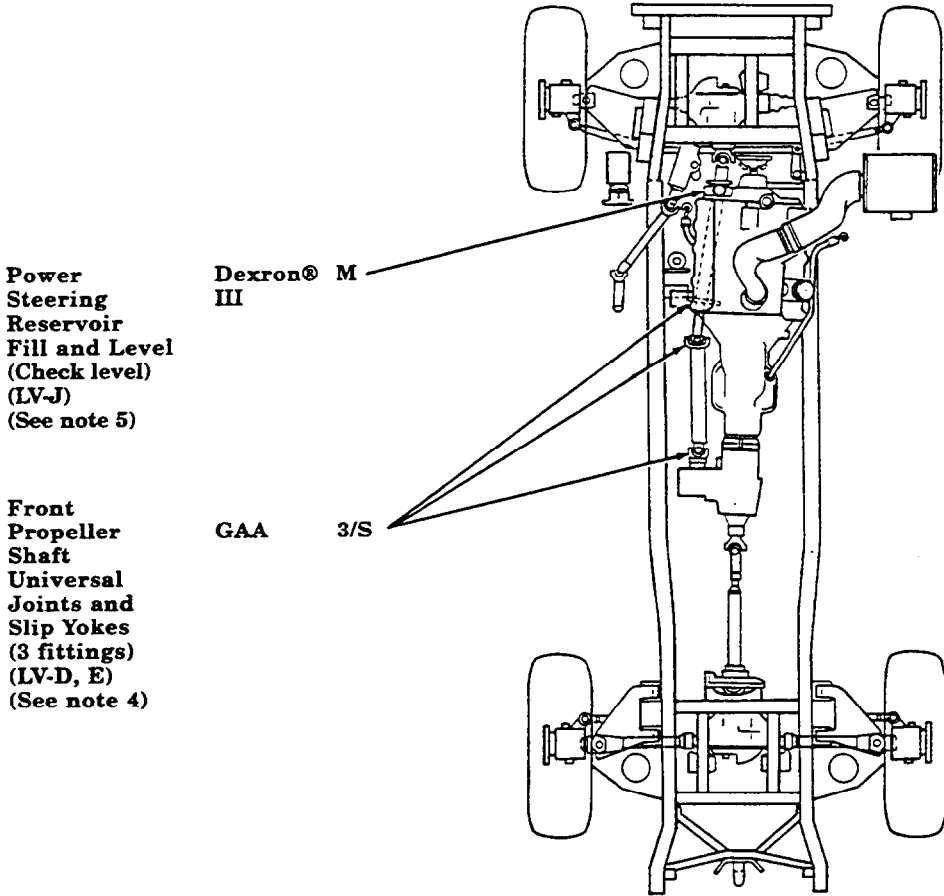

NOTE

A REFERENCE TO THE LOCALIZED VIEW (LV) IS PROVIDED AFTER LUBRICATION POINT ENTRY, WHERE APPLICABLE.

LUBRICATION POINTS (Cont'd)

INTERVAL • LUBRICANT

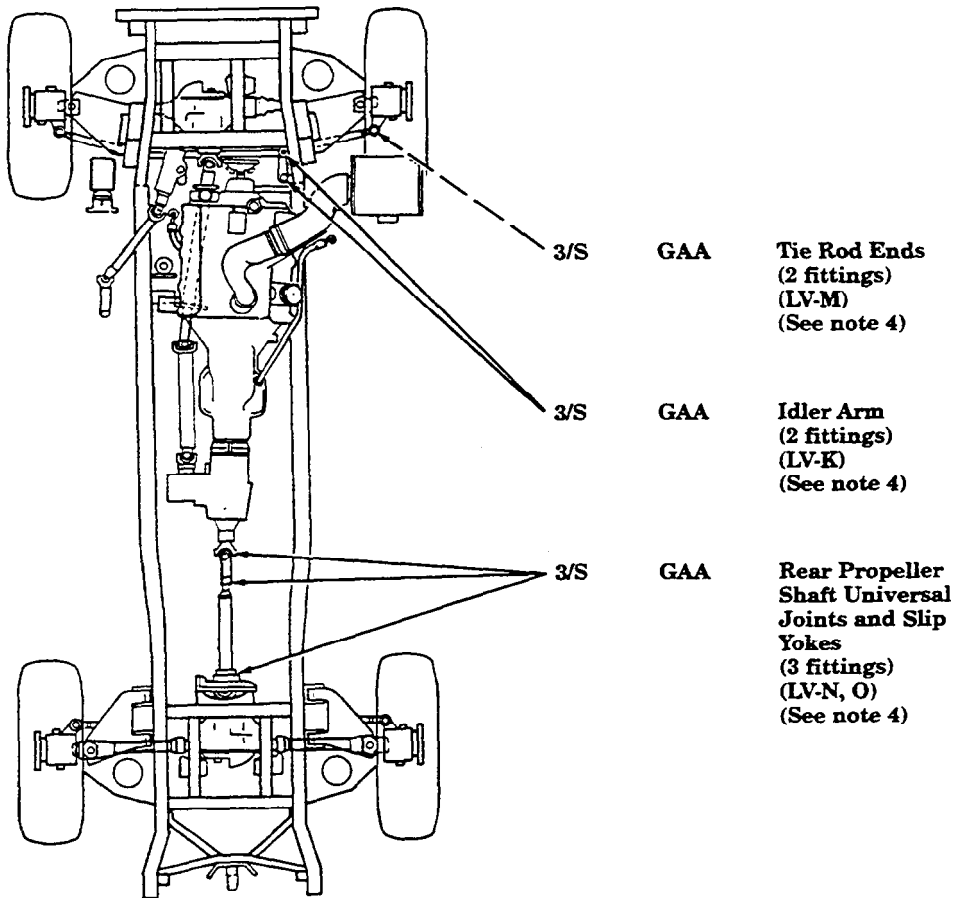

NOTE

A REFERENCE TO THE LOCALIZED VIEW (LV) IS PROVIDED AFTER LUBRICATION POINT ENTRY, WHERE APPLICABLE.

LUBRICATION POINTS (Cont'd)

LUBRICANT • INTERVAL

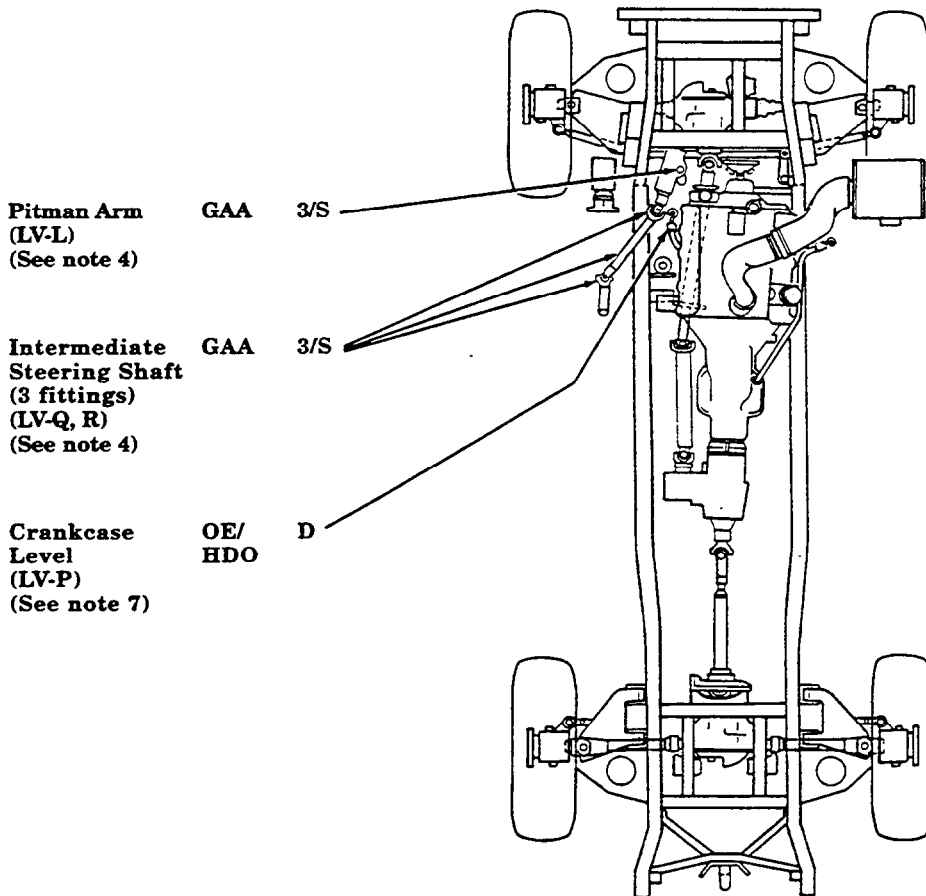

NOTE

A REFERENCE TO THE LOCALIZED VIEW (LV) IS PROVIDED AFTER LUBRICATION POINT ENTRY, WHERE APPLICABLE.

LOCALIZED LUBRICATION POINTS

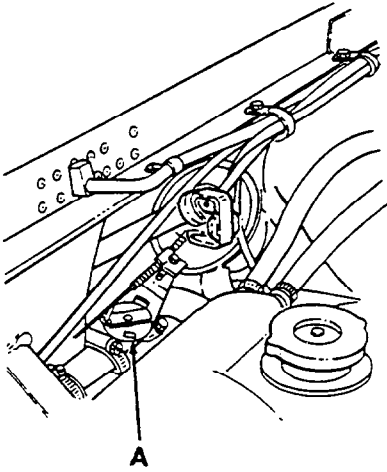

**HEATER CONTROL SHUTOFF
VALVE LEVER AND PIN**

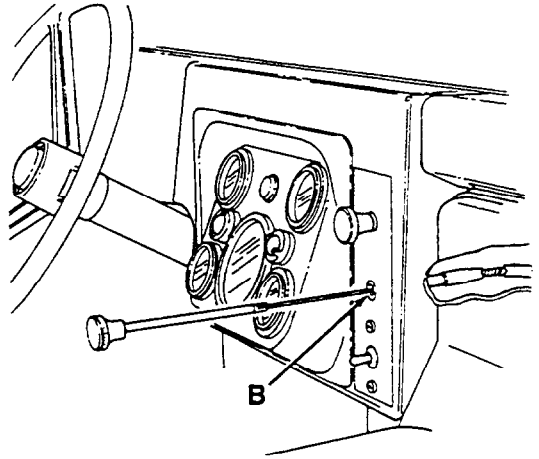

**HEATER CONTROL KNOB AND
PLUNGER**

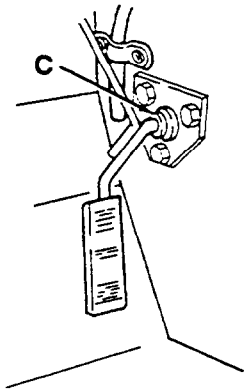

ACCELERATOR LINKAGE

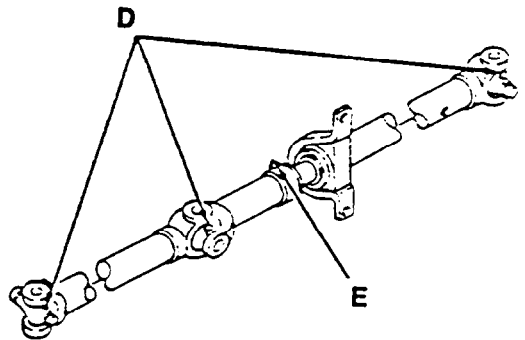

**FRONT PROPELLER SHAFT UNIVERSAL
JOINT AND SLIP YOKES**

LOCALIZED LUBRICATION POINTS (Cont'd)

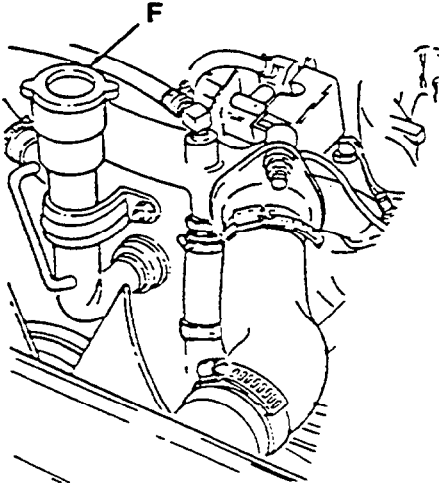

CRANKCASE FILL

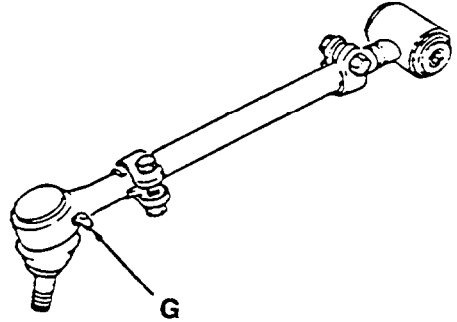

RADIUS ROD

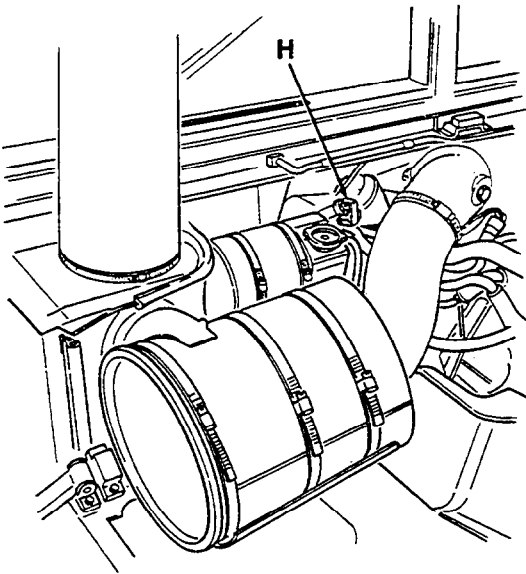

TRANSMISSION FILL
AND LEVEL

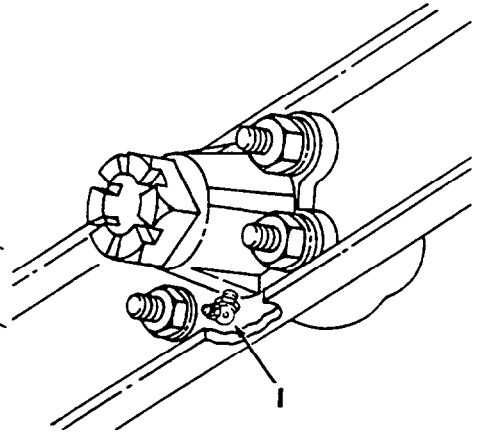

PINTLE

LOCALIZED LUBRICATION POINTS (Cont'd)

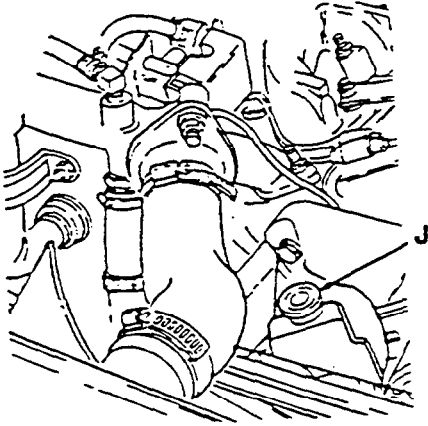

POWER STEERING RESERVOIR FILL
AND LEVEL

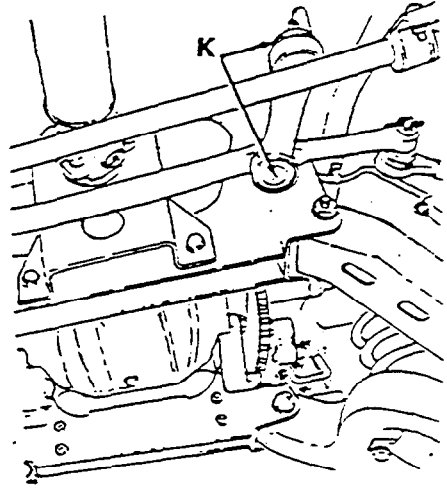

IDLER ARM

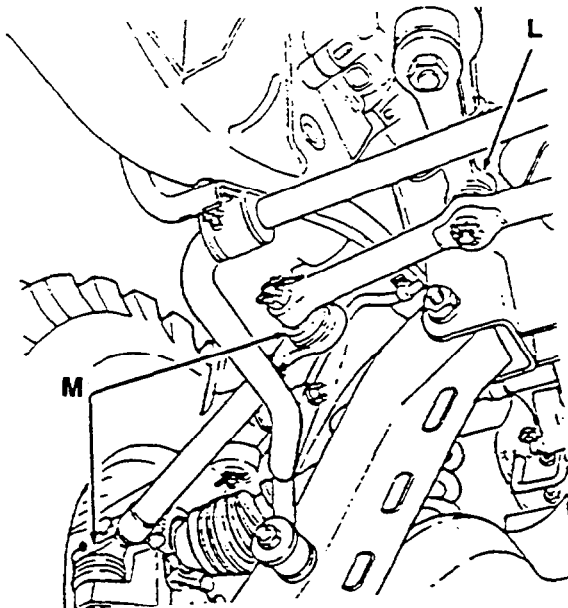

TIE ROD ENDS AND PITMAN ARM

LOCALIZED LUBRICATION POINTS (Cont'd)

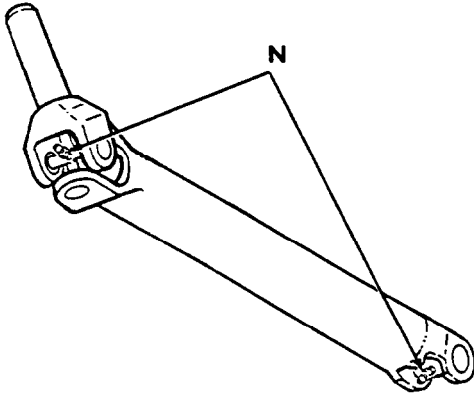

**REAR PROPELLER SHAFT UNIVERSAL JOINTS
AND SLIP YOKES**

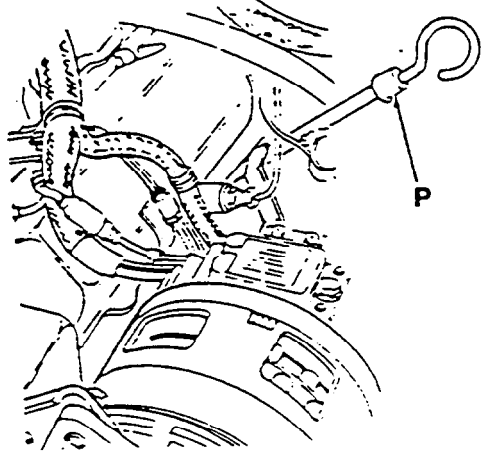

CRANKCASE LEVEL

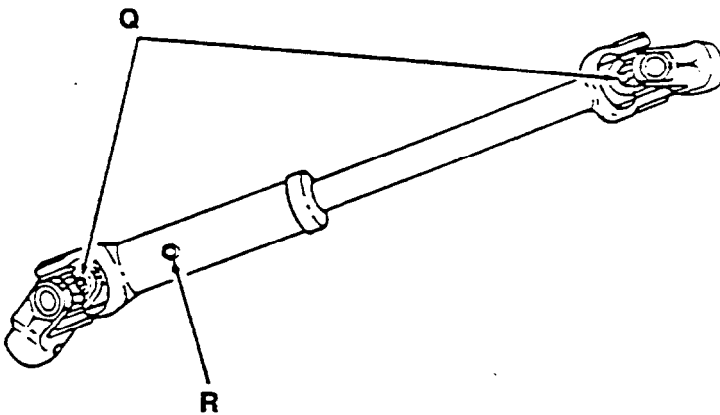

INTERMEDIATE STEERING SHAFT

NOTES

1. Oil Can Points.

Lubricate all oil can points every 3,000 mi (4,827 km), or semi-annually, whichever occurs first. Use seasonal grade OE on hood hinges, tailgate hinges, door hinges, door handles, transfer case shift linkage, accelerator linkage, transmission shift linkage, heater control shutoff valve lever and pin, heater control knob, and tiedown shackles and plunger. Lubricate cargo shell door paddle lock, rear wire handle lock, and cargo shell door latches with PL-S.

2. Winch Wire Rope.

WARNING

Wear leather gloves when handling winch wire rope. Do not handle wire rope with bare hands. Broken wires may cause injury.

NOTE

Front and rear winch lubrication is identical.

After each use, clean and lubricate winch wire rope. Clean entire wire rope with wire brush. If used frequently, lubricate with clean OE/HDO 30. If used infrequently, or in very damp or salty conditions, lubricate with EX. Do not lubricate winch wire rope in dry, dusty conditions. If used in arctic conditions, lubricate with GO 75. Perform winch wire rope cleaning and lubrication every 3,000 mi (4,827 km) or semiannually, whichever occurs first, when wire rope is not used.

3. Pintle.

Every 3,000 mi (4,827 km), or semiannually, whichever occurs first, clean pintle with wire bush and lubricate rear plate fitting with seasonal grade OE.

4. Steering System.

Lubricate front and rear propeller shaft, steering column, U-joints, slip yokes, tie rods, radius rods, pitman arm, intermediate steering shafts, and idler arm with GAA every 3,000 mi (4,827 km), or semiannually, whichever comes first.

5. Power Steering Reservoir.

CAUTION

Use Dexron® III for filling power steering reservoir. Failure to use Dexron® III may cause damage to power steering system.

Check the fluid level in the power steering reservoir monthly and adjust level as necessary. If fluid is hot, level should be between HOT and COLD marks on the cap indicator. If cool, level should be between ADD and COLD marks. In either condition, level must be above ADD mark. Fluid does not require periodic changing.

NOTES

6. Transmission.

CAUTION

- Do not overfill transmission. The fluid level rises as the fluid temperature increases. Therefore, do not check level before the transmission has reached normal operating temperature. The safe operating level is within the crosshatch marks on the dipstick. Overfilling may result in damage to transmission.
- Use Dexron® III for filling transmission. Failure to use Dexron® III may cause damage to transmission.

Check and fill transmission to proper level weekly. Operate transmission through all operating ranges to fill cavities and fluid passages. With vehicle positioned on level ground, allow engine to idle, shift transmission to neutral, and apply parking brake. Check fluid level on dipstick. It should register within the crosshatch marks under the conditions stated above. Have fluid changed every 12,000 mi (19,308 km), or biennially, whichever occurs first.

7. Crankcase Oil Level.

CAUTION

There are two marks on the dipstick: FULL and ADD 1 QT. The quantity of oil required to raise the oil level from ADD 1 QT mark to FULL mark is 1 qt (0.9 L). Do not overfill crankcase. Overfilling may result in damage to engine.

NOTE

- If oil level is above FULL, it may be due to oil cooler drain-back. Operate the engine for one minute, shut down, wait one minute, then recheck oil level.
- Oil is added to crankcase through fill tube which is located on top of engine.

Check crankcase oil level daily. Start engine and visually check for oil leaks at drainplug and oil filter. Stop engine and wait approximately one minute for oil to drain back into oil pan, then recheck oil level with dipstick. On vehicles equipped for deep water fording, the dipstick has a seal which fits into the opening of the dipstick tube. The dipstick handle must be turned counterclockwise to be released before dipstick is withdrawn. Turn handle clockwise to seat after installing dipstick. Have oil changed every 3,000 mi (4,827 km), or semiannually, whichever occurs first.

INDEX

	Para.	Page
A		
Additional authorization list (AAL), appendix C		C-1
Adjusting driver's seat	2-16	2-72
Air cleaner dump valve servicing	3-16	3-17
Air cleaner servicing (emergency procedure)	3-15	3-14
Air conditioner operation (M1114)	2-35	2-101
Appendix A, references		A-1
Appendix B, components of end item (COEI) and basic issue items (BII) lists		B-1
Appendix C, additional authorization list (AAL)		C-1
Appendix D, expendable/durable supplies and materials list		D-1
Appendix E, stowage and sign guide		E-1
Appendix F, on-vehicle equipment loading plans		F-1
Appendix G, lubrication instructions		G-1
Army regulations	A-8	A-2
B		
Basic issue items (BII) lists, components of end item (COEI), appendix B		B-1
Battery box cover replacement, companion seat assembly and	2-17	2-73
Batteries, servicing	3-12	3-12
Battery system operation	1-20	1-22
Break-in service, general information	1-7	1-3
Break-in service, operation under usual conditions	2-11	2-62
C		
Capacities (table 1-2)		1-6
Cargo shell door operation (M1114)	2-32	2-97
Cleaning compound-to-water ratio (table 3-2)		3-14
Cleaning instructions	2-5	2-26
Cold weather starting below +32°F (0°C)	2-41	2-106
Cooling system operation	1-17	1-16
Companion seat assembly and battery box cover replacement	2-17	2-73
Components of end item (COEI) and basic issue items (BII) lists, appendix B		B-1
Controls, indicators, and equipment	2-2	2-2
Coolant surge tank, servicing	3-10	3-10
Cooling system data (table 1-5)		1-8
Corrosion control	G-5	G-2
Corrosion prevention and control (CPC)	1-4	1-2
C-Pillar door operation (M1114)	2-31	2-96
Crew door operation (M1114)	2-30	2-95
Curb weight (table 1-12)		1-11
D		
Deep water fording (M1113) operation	2-48	2-114
Defroster operation (M1113)	2-19	2-75

INDEX (Cont'd)

	Para.	Page
D (Cont'd)		
Defroster operation (M1114)	2-20	2-76
Department of the army pamphlets, references	A-2	A-1
Differences between models (table 1-1)		1-6
Door operation (M1114), crew	2-30	2-95
Door operation (M1114), C-pillar	2-31	2-96
Driver's seat, adjusting	2-16	2-72
Drivetrain operation	1-15	1-14
Dusty, sandy areas, operating in	2-43	2-108
E		
Electric winch operation	2-28	2-90
Emergency fan clutch override	3-23	3-26
Engine data (table 1-4)		1-8
Engine oil servicing	3-18	3-19
Engine, starting the	2-12	2-62
Equipment characteristics, capabilities, and features	1-8	1-3
Equipment improvement report and maintenance digest (EIR MD)	1-6	1-3
Expendable/durable supplies and materials list, appendix D		D-1
Extreme cold, on ice or snow, operating in	2-42	2-107
Extreme heat, operating in	2-45	2-111
F		
Fan clutch override, emergency	3-23	3-26
Field manuals, references	A-4	A-1
Fire extinguisher operation	2-29	2-94
Fluid leakage	2-7	2-28
Fluid servicing, power steering	3-20	3-21
Fluid servicing, transmission	3-19	3-20
Fording (M1113) operation, deep water	2-48	2-114
Fording operation, shallow water	2-47	2-112
Forms, references	A-3	A-1
Fuel door operation (M1114)	2-34	2-100
Fuel filter maintenance	3-11	3-11
Fuel system operation	1-16	1-15
Fuel tank servicing	3-21	3-22
G		
General cleaning instructions (table 2-1)		2-26
General information		1-1
General lubricating instructions under unusual conditions	3-3	3-1
General lubrication instructions	3-2	3-1
General service data (table 1-3)		1-7
Generating system operation (200-ampere alternator)	1-19	1-20

INDEX (Cont'd)

	Para.	Page
H		
Hand receipt manual	1-3	1-2
Hatch stowage net, removal and installation	2-59	2-134
Heater operation	2-21	2-77
Heater operation, vehicular	2-50	2-122
Hood, raising and securing	3-9	3-8
K		
Know your controls and indicators	2-1	2-1
L		
Light switch, operation of vehicle	2-15	2-70
Loading plans, on-vehicle equipment, appendix F		F-1
Lubrication for continued operation below 0°F (-18°C)	3-4	3-1
Lubrication for operation under extreme temperatures	G-4	G-2
Lubrication instructions	3-1	3-1
Lubrication instructions, appendix G		G-1
Lubrication instructions, general	3-2	3-1
Lubrication instructions under unusual conditions, general	3-3	3-1
Lubrication intervals	G-3	G-2
Lubrication requirements	2-8	2-28
M		
Maintenance forms and records	1-2	1-1
Maximum vehicle operating speeds (table 1-8)		1-10
Max tool kit stowage (M1113) operation	2-24	2-80
Max tool kit stowage (M1114) operation	2-25	2-82
Metric system	1-9	1-3
Mirror adjustment, rearview	3-24	3-27
Miscellaneous publications, references	A-7	A-2
Mud, operating in	2-44	2-109
M1114 up-armored carriers w/supplemental armor load plan (MK19/40mm)	F-2	F-1
M1114 up-armored carriers w/supplemental armor load plan (M2/.50 cal)	F-3	F-6
M1113 load plan	F-4	F-10
O		
Oil servicing, engine	3-18	3-19
On-vehicle equipment loading plans, appendix F		F-1
Operating in dusty, sandy areas	2-43	2-108
Operating in extreme cold, on ice or snow	2-42	2-107
Operating in extreme heat	2-45	2-111
Operating in mud	2-44	2-109
Operating in rainy or humid conditions	2-46	2-112
Operating on unusual terrain	2-40	2-105
Operation of vehicle light switch	2-15	2-70

INDEX (Cont'd)

	Para.	Page
P		
Parking brake adjustment and cleaning	3-13	3-13
Parking brake system operation service/	1-22	1-24
Placing vehicle in motion	2-13	2-66
Plastic window cleaning	3-17	3-18
Power steering fluid servicing	3-20	3-21
Preventive maintenance checks and services (PMCS)	2-6	2-27
Preventive maintenance checks and services (table 2-2)		2-29
R		
Radiator cleaning	3-26	3-30
Rainy or humid conditions, operating in	2-46	2-112
Raising and securing hood	3-9	3-8
Rear seat stowage compartment net, removal and installation	2-60	2-135
Rearview mirror adjustment	3-24	3-27
References, appendix A		A-1
Removal and installation of hatch stowage net	2-59	2-134
Removal and installation of rear seat stowage compartment net	2-60	2-135
Removal and installation of stowage compartment net	2-58	2-133
Removal and installation of S250 shelter carrier rear suspension tiedown kit	2-55	2-130
Removal and installation of two-man crew area soft top enclosure	2-54	2-126
Reporting equipment improvement recommendations (EIRs)	1-5	1-2
Reservoir, servicing windshield washer	3-14	3-14
Runflat operation	2-49	2-121
Runflat operation (table 2-4)		2-121
S		
Scope of manual	1-1	1-1
Seatbelt operation	2-18	2-74
Service brake system operation	1-23	1-25
Service data, general (table 1-3)		1-7
Service/parking brake system operation	1-22	1-24
Servicing batteries	3-12	3-12
Servicing coolant surge tank	3-10	3-10
Servicing windshield washer reservoir	3-14	3-14
Shallow water fording operation	2-47	2-112
Slave starting operation	2-23	2-79
Special instructions	2-39	2-104
Starting the engine	2-12	2-62
Starting system operation	1-18	1-18
Steering control system operation	1-24	1-27
Stopping the vehicle and engine	2-14	2-68
Stowage and sign guide, appendix E		E-1
Stowage compartment net, removal and installation	2-58	2-133

INDEX (Cont'd)

	Para.	Page
S (Cont'd)		
Stowage plan, M1113	F-4	F-10
Stowage plan, M1114 (MK19/40 mm)	F-2	F-1
Stowage plan, M1114 (M2/.50 cal)	F-3	F-6
Surge tank, servicing coolant	3-10	3-10
Suspension system operation	1-25	1-29
S250 shelter carrier (M1113)	1-10	1-4
S250 shelter carrier rear suspension tiedown kit, removal and installation of	2-55	2-130
T		
Tables:		
1-1. Differences Between Models		1-6
1-2. Capacities		1-6
1-3. General Service Data		1-7
1-4. Engine Data		1-8
1-5. Cooling System Data		1-8
1-6. Transmission Data		1-8
1-7. Transfer Case Data		1-9
1-8. Maximum Vehicle Operating Speeds		1-10
1-9. Vehicle Dimensions		1-10
1-10. Vehicle Cruising Range		1-10
1-11. 9,000 lb Winch Data		1-11
1-12. Curb Weight		1-11
1-13. Vehicle Bridge Classification		1-11
2-1. General Cleaning Instructions		2-26
2-2. Preventive Maintenance Checks and Services		2-29
2-3. Towing Operation		2-84
2-4. Runflat Operation		2-121
3-1. Troubleshooting		3-3
3-2. Cleaning Compound-to-Water Ratio		3-14
G-1. Lubrication		G-3
Tabulated data	1-12	1-6
Tailgate operation	2-22	2-78
Technical bulletins, references	A-6	A-2
Technical manuals, references	A-5	A-2
Tire chain installation and removal	3-22	3-24
Towing operation	2-26	2-84
Trailer towing	2-27	2-89
Towing operations (table 2-3)		2-84
Transfer case data (table 1-7)		1-9
Transmission data (table 1-6)		1-8
Transmission fluid servicing	3-19	3-20
Troubleshooting (table 3-1)		3-3

INDEX (Cont'd)

	Para.	Page
T (Cont'd)		
Troubleshooting procedures.	3-6	3-2
Two-man crew area soft top enclosure, removal and installation of.	2-54	2-126
U		
Umbilical power cable, 200-ampere (M1113)	1-26	1-31
Up-armored carrier (M1114)	1-11	1-5
Up-armored carriers w/supplement armor load plan (M2/.50 cal), M1114	F-3	F-6
Up-armored carriers w/supplement armor load plan (MK19/40mm), M1114	F-2	F-1
Up-armored weapon station operation (M1114)	2-33	2-98
V		
Vehicle and engine, stopping the	2-14	2-68
Vehicle cruising range (table 1-10)		1-10
Vehicle dimensions (table 1-9)		1-10
Vehicle light switch, operation of	2-15	2-70
Vehicle operating speeds, maximum (table 1-8)		1-10
Vehicular heater operation	2-50	2-122
W		
Weight, curb (table 1-12)		1-11
Wheel assembly replacement	3-25	3-28
Winch operation, electric	2-28	2-90
Winch data, 9,000 lb (table 1-11)		1-11
Window cleaning, plastic	3-17	3-18
Windshield assembly operation	2-53	2-124
Windshield de-icer operation (M1114)	2-36	2-102
Windshield washer reservoir, servicing	3-14	3-14
Windshield wiper/washer system operation	1-21	1-23

By Order of the Secretary of the Army;

DENNIS J. REIMER
General, United States Army
Chief of Staff

Official:

JOEL B. HUDSON
Administrative Assistant to the
Secretary of the Army
03971

By Order of the Secretary of the Air Force:

RONALD R. FOGLEMAN
General, United States Air Force
Chief of Staff

Official:

HENRY VICCELLIO, JR.
General, United States Air Force
Commander, Air Force Materiel Command

DISTRIBUTION:

To be distributed in accordance with the initial distribution number (IDN) 381018, requirements for TM 9-2320-387-10.



THEN... JOT DOWN THE DOPE ABOUT IT ON THIS FORM. CAREFULLY TEAR IT OUT. FOLD IT AND DROP IT IN THE MAIL!

SOMETHING WRONG

WITH THIS PUBLICATION?

FROM: (PRINT YOUR UNIT'S COMPLETE ADDRESS)

Your mailing Address

DATE SENT

PUBLICATION NUMBER

TM 9-2320-387-10

PUBLICATION DATE

DATE OF TM

PUBLICATION TITLE

OPERATOR'S MANUAL

BE EXACT... PIN-POINT WHERE IT IS

IN THIS SPACE TELL WHAT IS WRONG AND WHAT SHOULD BE DONE ABOUT IT:

PAGE NO.	PARA-GRAPH	FIGURE NO.	TABLE NO.
2-47	2-5		2-2
2-47	2-5		2-2

ITEM 1 - Item reads break pedal (1)
Should read brake pedal (1).

ITEM 2 - Item reads lock pins (3)
Should read lock pins (1).

SAMPLE

PRINTED NAME, GRADE OR TITLE, AND TELEPHONE NUMBERS

YOUR NAME, RANK, AND PHONE

SIGN HERE:

PFC John Doe

SAMPLE

FILL IN YOUR
UNIT'S ADDRESS



DEPARTMENT OF THE ARMY

DIRECTOR
ARMAMENT AND CHEMICAL ACQUISITION AND LOGISTICS ACTIVITY
ATTN: AMSTA-AC-NMU
ROCK ISLAND, IL 61299-7630

TEAR ALONG PERFORATED LINE

FILL IN YOUR
UNIT'S ADDRESS



DEPARTMENT OF THE ARMY

DIRECTOR
ARMAMENT AND CHEMICAL ACQUISITION AND LOGISTICS ACTIVITY
ATTN: AMSTA-AC-NMLI
ROCK ISLAND, IL 61299-7630

TEAR ALONG PERFORATED LINE



SOMETHING WRONG

WITH THIS PUBLICATION?

THEN . . . JOT DOWN THE DOPE ABOUT IT ON THIS FORM. CAREFULLY TEAR IT OUT. FOLD IT AND DROP IT IN THE MAIL!

FROM: (PRINT YOUR UNIT'S COMPLETE ADDRESS)

DATE SENT

PUBLICATION NUMBER

TM 9-2320-387-10

PUBLICATION DATE

17 Oct 97

PUBLICATION TITLE

OPERATOR'S MANUAL

BE EXACT . . . PIN-POINT WHERE IT IS

IN THIS SPACE TELL WHAT IS WRONG AND WHAT SHOULD BE DONE ABOUT IT:

PAGE NO.	PARA-GRAPH	FIGURE NO.	TABLE NO.

PRINTED NAME, GRADE OR TITLE, AND TELEPHONE NUMBERS

SIGN HERE:

FILL IN YOUR
UNIT'S ADDRESS



DEPARTMENT OF THE ARMY

DIRECTOR
ARMAMENT AND CHEMICAL ACQUISITION AND LOGISTICS ACTIVITY
ATTN: AMSTA-AC-NMUJ
ROCK ISLAND, IL 61299-7630

TEAR ALONG PERFORATED LINE

FILL IN YOUR
UNIT'S ADDRESS



DEPARTMENT OF THE ARMY

DIRECTOR
ARMAMENT AND CHEMICAL ACQUISITION AND LOGISTICS ACTIVITY
ATTN: AMSTA-AC-NMU
ROCK ISLAND, IL 61299-7630

TEAR ALONG PERFORATED LINE

THE METRIC SYSTEM AND EQUIVALENTS

LINEAR MEASURE

- 1 Centimeter = 10 Millimeters = 0.01 Meters = 0.3937 Inches
- 1 Meter = 100 Centimeters = 1,000 Millimeters = 39.37 Inches
- 1 Kilometer = 1,000 Meters = 0.621 Miles

SQUARE MEASURE

- 1 Sq Centimeter = 100 Sq Millimeters = 0.155 Sq Inches
- 1 Sq Meter = 10,000 Sq Centimeters = 10.76 Sq Feet
- 1 Sq Kilometer = 1,000,000 Sq Meters = 0.386 Sq Miles

CUBIC MEASURE

- 1 Cu Centimeter = 1,000 Cu Millimeters = 0.06 Cu Inches
- 1 Cu Meter = 1,000,000 Cu Centimeters = 35.31 Cu Feet

LIQUID MEASURE

- 1 Milliliter = 0.001 Liters = 0.0338 Fluid Ounces
- 1 Liter = 1,000 Milliliters = 33.82 Fluid Ounces

TEMPERATURE

- 5/9 (°F - 32) = °C
- 212° Fahrenheit is equivalent to 100° Celsius
- 90° Fahrenheit is equivalent to 32.2° Celsius
- 32° Fahrenheit is equivalent to 0° Celsius
- 9/5 °C + 32 = °F

WEIGHTS

- 1 Gram = 0.001 Kilograms = 1,000 Milligrams = 0.035 Ounces
- 1 Kilogram = 1,000 Grams = 2.2 Lb
- 1 Metric Ton = 1,000 Kilograms = 1 Megagram = 1.1 Short Tons

APPROXIMATE CONVERSION FACTORS

TO CHANGE	TO	MULTIPLY BY
Inches	Centimeters	2.540
Feet	Meters	0.305
Yards	Meters	0.914
Miles	Kilometers	1.609
Square Inches	Square Centimeters	6.451
Square Feet	Square Meters	0.093
Square Yards	Square Meters	0.836
Square Miles	Square Kilometers	2.590
Acres	Square Hectometers	0.405
Cubic Feet	Cubic Meters	0.028
Cubic Yards	Cubic Meters	0.765
Fluid Ounces	Milliliters	29.573
Pints	Liters	0.473
Quarts	Liters	0.946
Gallons	Liters	3.785
Ounces	Grams	28.349
Pounds	Kilograms	0.454
Short Tons	Metric Tons	0.907
Pound-Feet	Newton-Meters	1.356
Pounds Per Square Inch	Kilopascals	6.895
Miles Per Gallon	Kilometers Per Liter	0.425
Miles Per Hour	Kilometers Per Hour	1.609

TO CHANGE	TO	MULTIPLY BY
Centimeters	Inches	0.394
Meters	Feet	3.280
Meters	Yards	1.094
Kilometers	Miles	0.621
Square Centimeters	Square Inches	0.155
Square Meters	Square Feet	10.764
Square Meters	Square Yards	1.196
Square Kilometers	Square Miles	0.386
Square Hectometers	Acres	2.471
Cubic Meters	Cubic Feet	35.315
Cubic Meters	Cubic Yards	1.308
Milliliters	Fluid Ounces	0.034
Liters	Pints	2.113
Liters	Quarts	1.057
Liters	Gallons	0.264
Grams	Ounces	0.035
Kilograms	Pounds	2.205
Metric Tons	Short Tons	1.102
Newton-Meters	Pound-Feet	0.738
Kilopascals	Pounds Per Square Inch	0.145
Kilometers Per Liter	Miles Per Gallon	2.354
Kilometers Per Hour	Miles Per Hour	0.621

